FIRESTOP CENTRE LIMITED

FIRE ASSESSMENT REPORT

*Service penetrations protected with Protecta FR Board
in accordance with AS 1530.4:2014 and
AS 4072.1:2005*



Report number: 51478400A
Revision: R3.0 Reference number: FAS200262
Issued date: 30 April 2026 Expiry date: 30 April 2031



JENSEN HUGHES

jensenhughes.com/pacific

Copyright ©2026 Jensen Hughes, Inc.
All Rights Reserved. T1124 PAC

Quality management

Revision	Date	Revision Description		
R1.0	Issue: 14 May 2018	Initial issue		
		Prepared	Reviewed	Authorised
		Mahmoud Akl	Omar Saad	N/A
R2.0	Issue: 25 Mar 2021	Report with additional assessed systems issued to Polyseam Ltd for review and comment.		
		Prepared	Reviewed	Authorised
		Sukhi Sendanayake	Mahmoud Akl	Omar Saad
R2.1	Issue: 23 Apr 2021	Report re-issued after addressing comments from report sponsor.		
		Prepared	Reviewed	Authorised
		Sukhi Sendanayake	Mahmoud Akl	Mahmoud Akl
R2.2	Issue: 17 May 2021	Report re-issued after addressing further comments from report sponsor.		
		Prepared	Reviewed	Authorised
		Sukhi Sendanayake	Mahmoud Akl	Mahmoud Akl
R3.0	Issue: 30 Apr 2026	Report revalidated for an additional 5 years.		
		Prepared	Reviewed	Authorised
		Expiry: 30 Apr 2031	Renz Rabusa	Edward Kwok

Jensen Hughes Fire Testing Pty Ltd
ABN 81 050 241 524
Formerly Warringtonfire Australia Pty Ltd¹

¹ Warringtonfire Australia Pty Ltd was acquired by Jensen Hughes in December 2023. Jensen Hughes Fire Testing Pty Ltd is not affiliated, associated, authorised, or endorsed by Warringtonfire Australia Pty Ltd, Warringtonfire Testing and Certification Limited or its "Warringtonfire" or "Certifire" brands.

Executive summary

This report documents the findings of the assessment undertaken to determine the fire resistance level (FRL) of service penetrations protected with Protecta FR Board in accordance with AS 1530.4:2014 and assessed in accordance with AS 4072.1:2005.

The intended use of Protecta FR Board – a coated mineral wool board – is to reinstate the fire resistance performance of flexible wall, rigid wall and floor constructions and timber wall and floor constructions where they are penetrated by various cables, metallic pipes, composite pipes and plastic pipes.

The Protecta FR Board is supplied coated on one face, referenced 1-S, or on both faces, referenced 2-S. The board or boards are then cut to allow the penetration of the required services before being inserted into the aperture in the wall or floor.

The analysis in sections 5.0 to 7.0 of this report found that the proposed systems, together with the described variations, will achieve the FRLs as shown in Table 1 – in accordance with AS 1530.4:2014 and assessed in accordance with AS 4072.1:2005.

The variations and outcome of this assessment are subject to the limitations and requirements described in sections 2.0, 3.0 and 8.0 of this report. The results of this report are valid until 30 April 2031.

Table 1 Overview of variations and assessment outcome

Item	Reference tests	Variations	Fire resistance levels (FRL)
1.	As given in Appendix B	The proposed variation is to assess the likely fire resistance performance if tested in accordance with AS 1530.4:2014 and AS 4072.1:2005.	As provided in section 5.0.
2.		Assess the performance of various types and sizes of cables, metallic pipes, composite pipes and plastic pipes protected with Protecta FR Boards and other supplementary fire sealing systems	As provided in section 6.0.
3.		Extension of FRLs to intermediate pipe sizes based on the testing of the maximum and minimum pipe size	
		<ul style="list-style-type: none"> + The separating elements are varied as follows: <ul style="list-style-type: none"> - Increase in aperture size protected with FR Boards. - The plasterboard wall partition tested in the referenced tests must include the option of lining with two layers of 13 mm thick fire grade plasterboard that has otherwise been tested or assessed as a wall to achieve an FRL of -/120/120 on each side of steel or timber framed wall. - The tested 50 mm thick stone wool cavity insulation can be provided as an option. - Applying test results obtained to masonry, AAC or concrete walls and bare rigid walls having minimum thickness of 75 mm. - The floor thickness to be reduced to 100 mm. - The integrity rating achieved for insulated pipes can be applied to uninsulated pipes. + The fire performance achieved by services penetrating FR boards and protected with FR Pipe Wraps can be extended to services passing through core-drilled holes in rigid walls and floors. The maximum annular gap must be 30 mm and the services are to be protected with FR Pipe Wraps on both the exposed and unexposed side in walls and the exposed side in floors. The rest of the annular gap must be filled with FR Acrylic sealant to the full depth in walls and to the depth of 15 mm in floors backed with 25 mm deep stone wool backing (minimum density 33 kg/m³). 	As provided in section 7.0.

Table of contents

Quality management.....	2
Executive summary.....	3
1.0 Introduction.....	7
2.0 Framework for the assessment.....	7
2.1 Assessment approach.....	7
2.2 Compliance with the National Construction Code.....	8
2.3 Declaration.....	8
3.0 Requirements and limitations of this assessment.....	9
4.0 Description of the specimen and variations.....	10
4.1 Description of assessed systems.....	10
4.2 Referenced test data.....	13
4.3 Variations to the tested systems.....	13
4.4 Test standard.....	15
4.5 Reference standard.....	15
5.0 Assessment 1 – Applicability of test results in accordance with AS 1530.4:2014.....	16
5.1 Description of variation.....	16
5.2 Methodology.....	16
5.3 Assessment.....	16
6.0 Assessment 2 – Fire resistance performance of services penetrating Protecta FR Board.....	21
6.1 Description of variation.....	21
6.2 Methodology.....	21
6.3 Assessment.....	21
7.0 Assessment 3 – Assessment of specific variations.....	106
7.1 Description of variation.....	106
7.2 Methodology.....	106
7.3 Assessment.....	106
8.0 Validity.....	110
Appendix A Drawings and additional information.....	111
Appendix B Summary of supporting test data.....	112
B.8 Test report – WF 395179.....	128
B.9 Test report – WF 392646.....	129
B.10 Test report – WF 398517.....	130
B.11 Test report – WF 384982 Revision A.....	131
B.12 Test report – WF 401855 Revision A.....	133
B.13 Test report – WF 408361.....	135
B.14 Test report – WF 407685.....	137
B.15 Test report – WF 383813.....	140
B.16 Test report – WF 394232.....	142
B.17 Test report – WF 19723.....	143

B.18	Test report – WF 419414	145
B.19	Test report – WF 410203	147
B.20	Test report – WF 19479A	148
B.21	Test report – UL 4788787025	149
B.22	Test report – WF 375339	150
B.23	Test report – WF 375344	151
B.24	Test report – WF 375797	152
B.25	Test report – WF 376483	153
B.26	Test report – WF 379105	156
B.27	Test report – WF 380112	157
B.28	Test report – WF 380977	158

1.0 Introduction

This report documents the findings of the assessment undertaken to determine the fire resistance level (FRL) of service penetrations protected with Protecta FR Board in accordance with AS 1530.4:2014² and assessed in accordance with AS 4072.1:2005³.

This report may be used as evidence of suitability in accordance with the requirements of the relevant National Construction Code (NCC) to support the use of the material, product, form of construction or design as given within the scope of this assessment report. It also references test evidence for meeting deemed-to-satisfy (DTS) provisions of the NCC that apply to the assessed systems.

This assessment was carried out at the request of Firestop Centre Limited. The sponsor details are included in Table 2.

Table 2 Sponsor details

Sponsor	Address
Firestop Centre Limited	Unit J, 657 Great South Road Penrose Auckland 1061 New Zealand

2.0 Framework for the assessment

2.1 Assessment approach

An assessment is a professional opinion about the expected performance of a component or element of structure subjected to a fire test.

No specific framework, methodology, standard or guidance documents exists in Australia for undertaking these assessments. We have therefore followed the 'Guide to undertaking technical assessments of the fire performance of construction products based on fire test evidence' prepared by the Passive Fire Protection Forum (PFPF) in the UK in 2021⁴.

This guide provides a framework for undertaking assessments in the absence of specific fire test results. Some areas where assessments may be offered are:

- + Where a modification is made to a construction which has already been tested
- + The interpolation or extrapolation of results of a series of fire resistance tests, or utilisation of a series of fire test results to evaluate a range of variables in a construction design or a product
- + Where, for various reasons – eg size or configuration – it is not possible to subject a construction or a product to a fire test.

Assessments can vary from relatively simple judgements on small changes to a product or construction through to detailed and often complex engineering assessments of large or sophisticated constructions.

² Standards Australia, 2014, Methods for fire tests on building materials, components and structures – Part 4: Fire-resistance tests for elements of construction, AS 1530.4:2014, Standards Australia, NSW.

³ Standards Australia, 2005, Components for the protection of openings in fire-resistant separating elements: Service penetrations and control joints (Reconfirmed 2016), AS 4072.1:2005, Standards Australia, NSW.

⁴ Passive Fire Protection Forum (PFPF), 2021, Guide to undertaking technical assessments of the fire performance of construction products based on fire test evidence, Passive Fire Protection Forum (PFPF), UK.

This assessment uses established empirical methods and our experience of fire testing similar products to extend the scope of application by determining the limits for the design and performance based on the tested constructions and performances obtained. The assessment is an evaluation of the potential fire resistance performance of the elements in accordance with AS 1530.4:2014.

This assessment has been written in accordance with the general principles outlined in EN 15725:2023⁵ for extended application on the fire performance of construction products and building elements: Principle of EXAP standards and EXAP reports.

This assessment has been written using appropriate test evidence generated at accredited laboratories to the relevant test standard. The supporting test evidence has been deemed appropriate to support the manufacturer's stated design.

2.2 Compliance with the National Construction Code

This assessment report has been prepared to meet the evidence of suitability requirements of the NCC 2022⁶ under A5G3(1)(d). It references test evidence for meeting deemed-to-satisfy (DTS) provisions of the NCC under A5G5 for fire resistance level that apply to the assessed systems based on Specifications 1 and 2 for fire resistance for building elements.

The proposed details and systems (building elements) in this report are confirmed to be assessed, without the aid of an active fire suppression system, based on prototype tests that are equivalent to or more severe than a standard fire test as specified in section 4.4, in accordance with NCC 2022 S1C2(b). It is also confirmed that the differences between the proposed systems and details compared to the tested prototypes are considered minor in accordance with NCC 2022 S1C2(c).

This assessment report may also be used to demonstrate compliance with the requirements for evidence of suitability under the relevant sections of previous versions of the NCC.

2.3 Declaration

The 'Guide to undertaking technical assessments of the fire performance of construction products based on fire test evidence' prepared by the PFPF in the UK requires a declaration from the client. By accepting our fee proposal on 13 February 2026, Firestop Centre Limited confirmed that:

- + To their knowledge, the variations to the component or element of structure, which is the subject of this assessment, have not been subjected to a fire test to the standard against which this assessment is being made.
- + They agree to withdraw this assessment from circulation if the component or element of structure is the subject of a fire test by a test authority in accordance with the standard against which this assessment is being made and the results are not in agreement with this assessment.
- + They are not aware of any information that could adversely affect the conclusions of this assessment and – if they subsequently become aware of any such information – they agree to ask the assessing authority to withdraw the assessment.

⁵ European Committee for Standardization, 2023, Extended application on the fire performance of construction products and building elements: Principle of EXAP standards and EXAP reports, EN 15725:2023, European Committee for Standardization, Brussels, Belgium.

⁶ National Construction Code Volumes One and Two - Building Code of Australia 2022, Australian Building Codes Board, Australia.

3.0 Requirements and limitations of this assessment

- + The scope of this report is limited to an assessment of the variations to the tested systems described in section 4.3.
- + This report details the methods of construction, test conditions and assessed results in accordance with AS 1530.4:2014.
- + The results of this assessment are applicable to fire exposure from either side for the assessed wall systems and fire exposure from below for the assessed floor systems.
- + While it is recommended that for the elastomeric pipe insulation to be classified B-s3 as tested, the achieved results can be extended to cover an insulation material not deemed combustible as determined by AS 1530.1:1994⁷.
- + For CLT walls, density must be minimum 510 kg/m³ and the adhesive used must be in the family of heat-resistant melamine-urea-formaldehyde. The outer lamella thicknesses must be equal to or greater than 18.5 mm.
- + For CLT floors, density must be minimum 480 kg/m³ and the adhesive used must be in the family of heat-resistant melamine-urea-formaldehyde. The slab thickness must be minimum 150 mm. The outer lamella thicknesses must be equal to or greater than 30 mm.
- + In systems where insulation installed on metallic and composite pipes is interrupted, it has been established that the insulation does not contribute to the integrity rating of the system. Therefore, assuming insulation is zero, the integrity rating achieved must be maintained when such systems are used on uninsulated pipes.
- + Support of services in walls and floors must be maintained as per AS 1530.4:2014 and AS 4072.1:2005 requirements.
- + This report relies on test evidence and applies only to the specific specimens tested. It does not verify ongoing compliance or the performance of future production batches.
- + This assessment report has been prepared based on the fire resistance performance and condition of the systems at the time they were tested. Any deterioration of fire resistance performance due to external factors including but not limited to passage of time and exposure to elements – is not considered in this report.
- + Jensen Hughes has provided this report on the fire performance of building elements in a controlled laboratory setting, strictly within the parameters allowed by the test standards and building regulations. The outcomes of this report are intended to assist in verifying the suitability of the product or system for practical use in specific applications.
- + This report is only valid for the assessed systems and must not be used for any other purpose. Any changes with respect to size, construction details, loads, stresses, edge or end conditions – other than those identified in this report – may invalidate the findings of this assessment. If there are changes to the system, a reassessment will need to be done by an Accredited Testing Laboratory (ATL) that is accredited to the same nominated standards of this report.

⁷ Standards Australia, 1994, Methods for fire tests on building materials, components and structures – Part 1: Combustibility test for materials, AS 1530.1:1994, Standards Australia, NSW.

- + This report has been prepared using information provided by others. Jensen Hughes has not verified the accuracy and/or completeness of that information and will not be responsible for any errors or omissions that may have been incorporated into this report as a result.
- + This assessment is based on the proposed systems being constructed under comprehensive quality control practices and following appropriate industry regulations and Australian Standards on quality of materials, design of structures, guidance on workmanship and expert handling, placing and finishing of the products on site. These variables are beyond the control and consideration of this report.

4.0 Description of the specimen and variations

4.1 Description of assessed systems

Protecta FR Board is a coated mineral wool board used to reinstate the fire resistance performance of wall and floor constructions where they have been provided with apertures for the penetration of single or multiple services. The Protecta FR Board is supplied coated on one face, referenced 1-S, or on both faces, referenced 2-S. The board or boards are then cut to allow the penetration of the required services, before being inserted into the aperture in the wall or floor.

Protecta FR Pipe Wraps can be used in conjunction with Protecta FR Board depending upon the required application and FRL.

1. The intended use of Protecta FR Board is to reinstate the fire resistance performance of flexible wall, rigid wall and floor constructions, and timber wall and floor constructions where they are penetrated by various cables, metallic pipes, composite pipes and plastic pipes.
2. The specific elements of construction that the system Protecta FR Board may be used to provide a penetration seal in, are as follows:
 - a. Flexible walls: The wall must have a minimum thickness of 75 mm and comprise steel or timber studs* lined on both faces with minimum 1 layer of 12.5 mm thick plasterboards. Walls are required to be otherwise tested or assessed by others to achieve the required FRL. Apertures are not required to be lined. Wall cavity insulation is optional.
 - b. Timber walls: The wall must have a minimum thickness of 100 mm and comprise solid wood or cross-laminated timber. Density must be minimum 510 kg/m³ and the adhesive used must be in the family of heat-resistant melamine-urea-formaldehyde. The outer lamella thicknesses must be equal to or greater than 18.5 mm.
 - c. Rigid walls: The wall must have a minimum thickness of 75 mm and comprise concrete, aerated concrete or masonry, with a minimum density of 650 kg/m³. Wall elements are required to be otherwise tested or assessed by others for the required fire resistance period.
 - d. Rigid floors: The floor must have a minimum thickness of 150 mm and comprise aerated concrete or concrete with a minimum density of 650 kg/m³. Floor elements are required to be otherwise tested or assessed by others for the required fire resistance period.

Applicability of FRLs to thinner concrete slab of minimum thickness 100 mm with minimum density of 650 kg/m³ is permissible. Insulation performance of the system will be governed by the concrete slab thickness as stated in AS/NZS 3600:2018⁸. The overall FRL of the system will be governed by the FRL extracted from AS/NZS 3600:2018.

⁸ Standards Australia, 2018, Concrete structures, AS 3600:2018 (Incorporating Amendment No. 1), Standards Australia, NSW.

Floors are required to be otherwise tested or assessed by others to achieve a nominated FRL. In cases where the FRL of the floor is less than the penetration protecting the overall system, the FRL will be derated accordingly.

- e. Timber floors: The floor must have a minimum thickness of 150 mm and comprise solid wood or cross-laminated timber. Density must be minimum 480 kg/m³ and the adhesive used must be in the family of heat-resistant melamine-urea-formaldehyde. The slab thickness must be minimum 150 mm. The outer lamella thicknesses must be equal to or greater than 30 mm.

For timber framed walls, it is required that no part of the penetration seal is closer than 100 mm to a stud, the cavity is closed between the penetration seal and the stud, and minimum 100 mm of insulation confirmed to be deemed non-combustible in accordance with AS 1530.1:1994 must be provided within the cavity between the penetration seal and the stud.

Wall and floor elements are required to be otherwise tested or assessed by others for the required fire resistance period. In cases where the FRL of the wall or floor is less than that of the penetration, the FRL will be derated accordingly.

Protecta Fire Protection Systems which involve services penetrating both sides of a flexible wall may also be used in the situation where the services penetrate one side of the wall only and the remaining side of the wall is not penetrated at the same point (i.e. the services continues on the inside of the wall). All fire integrity and insulation ratings for such single-sided penetrations remain the same as for the equivalent double-sided penetrations for all services except bare metallic pipes. For bare metallic pipes, the thermal insulation ratings will be required to be derated unless a 13 mm or 16 mm baffle system is installed on the unexposed side as per the application.

- 3. The system Protecta FR Board may be used to provide a penetration seal with cables, cable trays, metallic pipes, composite pipes and plastic pipes, with and without insulation, with mixed services within the same seal/aperture.

Test results for cables remain valid if the diameter of a single cable is reduced and/or the number of cables in a bunch is reduced provided that the overall diameter of the bunch of any individual cable is not greater than that tested.

The test results obtained with the standard configuration cover all types of insulated cables with copper or aluminium conductors, fibre optic cables and bundled communication cables, except hollow cables.

Results obtained from tests where the supports pass through the seal are applicable to those situations where the support is not continued but not vice versa.

- 4. The total amount of cross sections of services (including insulation) should not exceed 60% of the penetration area. The test results obtained using standard configuration for cable penetration systems are valid for:
 - a. All type of steel cable trays and ladders
 - b. Any penetration size equal or smaller than that tested, provided the total amount of cross sections of the cables (core and insulation) does not exceed 60% of the penetration.
- 5. In systems where insulation installed on metallic and composite pipes is interrupted, it has been established that the insulation doesn't contribute to the integrity rating of the system. Therefore, assuming insulation is zero, the integrity rating achieved must be maintained when such systems are used on uninsulated pipes.

6. The system Protecta FR Board may be used to seal apertures in the separating element of unlimited width by 1200 mm high in a wall (uninterrupted separating studs will be required at 2400 mm centres or less in flexible walls), and 2400 mm by 1200 mm in a floor. The additional sizes that are permitted in floors are the following:

Where 2400 mm × 1200 mm is specified in section 7.0:

Width (mm)	Length (mm)
1100	2620
1000	2880
≤800	∞ (infinite)

Where 1200 mm × 600 mm is specified in section 7.0

Width (mm)	Length (mm)
500	1800
≤800	∞ (infinite)

The minimum permitted separation between adjacent seals/apertures is 200 mm. Services should be a minimum of 25 mm from seal edges. Services within the system Protecta FR Board seal do not require a minimum separation, except pipes where combustible pipe insulation penetrates the seal and plastic pipe penetrations which should be a minimum of 30 mm from other services in the aperture.

7. Support of services in walls and floors must be maintained as per AS 1530.4:2014 and AS 4072.1:2005 requirements.
8. It was confirmed that where PP pipes are mentioned, this includes PP-MV, PP-H, PP-R and similar. Where PE pipes are mentioned, this includes PE-LD, PE-MD, PE-HD, PE-X and similar.
9. A pattress system is boards installed on the surface of a wall instead of inside the aperture which can be used as an alternative installation method, limited to -/120/120. The aperture can be located within the wall with maximum size 1100 × 1100 mm or towards the soffit with maximum size 550 mm high × 1100 mm wide. The boards must be oversailing the aperture by 50 mm on both sides of the wall, bonded to the wall with FR Coating and fixed with ≥ 5 × 100 mm single thread wood, masonry or concrete screws and penny washers of steel at 300 mm centres. Exposed board edges must be coated with Protecta FR Coating. Soffit applications can be fixed on three sides.
10. FRLs in section 7.0 for 100 mm thick flexible walls, can be used in timber walls provided that the density is minimum 510 kg/m³ and the adhesive used must be in the family of heat-resistant melamine-urea-formaldehyde. The outer lamella thicknesses must be equal to or greater than 18.5 mm (see 2.b) if installed as a pattress system on the surface of a wall instead of inside the aperture. The aperture can be maximum 600 mm high × 1200 mm wide. The boards must be oversailing the aperture by 100 mm on both sides of the wall, fixed to the wall with ≥ 100 mm wood screws and penny washers of steel at 300 mm centres. The gap between board and wall must have a bead of Protecta FR Acrylic. Exposed board edges must be coated with Protecta FR Coating.
11. FRLs in section 7 for 100 mm thick flexible walls with double layer 50 mm thick boards, can be used in 75 mm thick flexible and rigid walls with a maximum aperture of 1200 mm high × 900 mm wide, limited to -/60/60 unless specified otherwise in section 7.0. The boards must be positioned centrally within the wall, and any exposed mineral fibres must be coated with FR Coating.

Refer to section 6.0 for the assessed FRL given to each construction configuration.

4.2 Referenced test data

The assessment of the variation to the tested systems and the determination of the performance are based on the results of the fire tests documented in the reports summarised in Table 3. Further details of the tested systems are included in Appendix B.

Table 3 Referenced test data

Report number	Test sponsor	Test date	Testing authority
WF 423530	Polyseam	29 January 2020	Warringtonfire UK
WF 427934		14 April 2020	
WF 419763		19 November 2019	
WF 398928 Revision A		6 August 2018	
WF 398517 Revision B		19 April 2018	
WF 419764		12 December 2019	
WF 411108		1 March 2019	
WF 395179		6 February 2018	
WF 392646		29 November 2017	
WF 398517		19 April 2018	
WF 384982 Revision A		29 June 2017	
WF 401855 Revision A		5 July 2018	
WF 408361		18 December 2018	
WF 407685		29 November 2018	
WF 383813		25 May 2017	
WF 394232		11 January 2018	
WF 19723		25 June 2019	WFRGENT NV, Belgium
WF 419414		24 October 2019	
WF 410203		17 February 2019	
WF 19479A		14 January 2019	WFRGENT NV, Belgium
UL 4788787025	2 November 2016	UL International (UK) Ltd	
WF 375339	28 February 2019	Warringtonfire, UK	
WF 375344	26 October 2016		
WF 375797	9 March 2017		
WF 376483	29 November 2016		
WF 379105	26 January 2017		
WF 380112	16 February 2017		
WF 380977	16 March 2017		

4.3 Variations to the tested systems

The tested systems and variations to those tested systems – together with the referenced standard fire tests – are described in Table 4.

Table 4 Variations to tested systems

Item	Reference test	Description	Variations
1.	As given in Appendix B	The referenced tests were conducted in accordance with BS EN 1366-3:2009 ⁹ and BS EN 1363-1:2012 ¹⁰	Assess the performance of various types and sizes of cables, metallic pipes, composite pipes and plastic pipes protected with Protecta FR Boards and other supplementary fire sealing systems in accordance with AS 1530.4:2014 and AS 4072.1:2005.
2.		The referenced tests were conducted to demonstrate how the Protecta FR Board reinstates the fire resistance performance of flexible wall, rigid wall and floor constructions, and timber wall and floor constructions where they are penetrated by various cables, metallic pipes, composite pipes and plastic pipes	Extension of FRLs to intermediate pipe sizes based on the testing of the maximum and minimum pipe size
3.			<p>The separating element is varied as follows:</p> <ul style="list-style-type: none"> + Increase in aperture size protected with FR Boards. + The plasterboard wall partition tested in the referenced tests shall include the option of lining with two layers of 13 mm thick fire grade plasterboard that has otherwise been tested or assessed as a wall to achieve a FRL -/120/120 on each side of steel or timber framed wall. + The tested 50 mm thick stone wool cavity insulation must be provided as an option. + Applying test results obtained to masonry, AAC or concrete walls and bare rigid walls having minimum thickness of 75 mm. + The floor thickness to be reduced to 100 mm. + The integrity rating achieved for insulated pipes can be applied to uninsulated pipes. <p>The fire performance achieved by services penetrating FR boards can be extended to services passing through core-drilled holes in rigid walls and floors. The maximum annular gap is 30 mm and the services are to be protected with FR Pipe Wraps on both the exposed and unexposed side in walls and the exposed side in floors. The rest of the annular gap is to be filled with FR Acrylic sealant to the full depth in walls and to the depth of 15 mm in floors backed with 25 mm deep stone wool backing (minimum density 33 kg/m³).</p>

⁹ European Committee for Standardization, 2009, Fire resistance tests for service installations. Penetration seals, BS EN 1366-3:2009, European Committee for Standardization, Brussels, Belgium.

¹⁰ European Committee for Standardization, 2012, Fire resistance tests – General requirements, BS EN 1363-1:2012, European Committee for Standardization, Brussels, Belgium.

4.4 Test standard

AS 1530.4:2014 sets out procedures and methods for fire tests on building materials, components, structures, and fire-resistance tests for elements of construction. Section 10 discusses the procedures and methods for service penetrations and control joints.

4.5 Reference standard

AS 4072.1:2005 sets out the minimum requirements for the construction, installation and application of fire resistance tests to sealing systems around penetrations through separating building elements that are required to have an FRL.

5.0 Assessment 1 – Applicability of test results in accordance with AS 1530.4:2014

5.1 Description of variation

This assessment report is prepared based on referenced tests provided in Appendix B describing fire resistance testing of fire seals and service penetration protection in various fire separating elements, tested in accordance with BS EN 1363-1:2012, BS EN 1366:3 2009 and BS EN 1366-4:2006. These standards differ from AS 1530.4:2014. The effect these differences have on the fire resistance performance of the test specimens if tested in accordance with AS 1530.4:2014 is discussed below.

5.2 Methodology

The method of assessment used is summarised in Table 5.

Table 5 Method of assessment

Assessment method	
Level of complexity	Complex assessment
NCC procedure for determining fire performance	Differs in only a minor degree from a tested prototype S1C2(b) and S1C2(c)
Type of assessment	Qualitative and comparative

5.3 Assessment

5.3.1 Specimen configuration

AS 1530.4:2014 specifies that the service(s) shall be installed so that it projects a minimum 500 mm on each side of the supporting construction, of which at least 200 mm shall extend beyond the extremities of the penetration sealing system. The penetration sealing system shall include any coating, wrapping or other protections to the services. The length of unprotected service on the unexposed face shall not be greater than 500 mm. For plastic pipes, the external projection away from the furnace shall be increased to a minimum of 2000 mm. The measurements shall not include any part of the plug or cap used to seal a pipe within the furnace.

With respect to the pipe end configurations, AS 1530.4:2014 stipulates that services end conditions shall be representative of those intended to be used in practice.

The EN standard stipulates the following field of application based on the tested pipe end configuration:

Table 6 Field of application rules for pipe end configurations

		Tested			
		U/U	C/U	U/C	C/C
Covered	U/U	Y	N	N	N
	C/U	Y	Y	N	N
	U/C	Y	Y	Y	N
	C/C	Y	Y	Y	Y
Y=acceptable, N=not acceptable					

Based on the review of the test data and the above field of application, it is the opinion of this testing authority that services tested with an open/open end fire configuration are considered to be the worst-case scenario as the hot gases will have a clear path to the unexposed side. As a result, the thermocouple placed on the service will likely record the highest temperature when compared to the rest of the pipe end configurations. Therefore, FRL achieved in U/U configuration can be extended to services tested in any of the pipe end configurations.

With respect to the services tested in an open/closed configuration or closed/closed configuration, it is considered that both configurations are not in line with the general requirement of the AS 1530.4:2014. However, AS 1530.4:2014 stipulates that "service end conditions shall be representative of those intended to be used in practice", therefore, it is reasonable to extend the FRL achieved in both configurations provided that they are representative of the system used in practice.

With respect to the difference in the pipe projection from the wall and the floor system, it is considered that this difference will not likely introduce any detrimental effect to the wall system, as the plastic pipe is expected to melt in the first few minutes in a test, and once the sealant is activated, this difference can be negligible.

In case of a floor system, it is argued that having a 2000 mm projection out of the floor slab at the unexposed side may include a detrimental effect due to stack effect but it is also argued that 500 mm projection as stipulated in the BS EN standard could also be considered as the most onerous case as more hot gases are expected to pass from the exposed to the unexposed side at a faster rate, hence increasing the temperature recorded by the TC placed on the service before the activation and closure of the fire rated sealant.

A 2000 mm pipe length on the unexposed side represents a slightly higher level of demand. Any short term heat sink effect exists only briefly before pipe softening and melting dominate behaviours. This influence is offset by the severity of the EN furnace curve during the early stages of exposure.

In conclusion, considerable amount of research and test history has showed that the extension of the pipe from the unexposed side will not likely have an impact on the performance of the plastic pipes, hence it can be positively assessed.

5.3.2 Furnace temperature measurement

The furnace thermocouples specified in AS 1530.4:2014 are type K, mineral insulated metal sheathed (MIMS), with a stainless-steel sheath having a wire of diameter of less than 1.0 mm and an overall diameter of 3 mm. The measuring junction protrudes at least 25 mm from the supporting heat resistant tube.

The furnace thermocouples specified in EN 1363-1:2012 are plate thermometers comprised of an assembly of a folded nickel alloy plate, a thermocouple fixed to it and insulation material. A thermocouple is fixed to the side of the plate facing the specimen, with the thermocouple hot junction protected by a pad of insulating material.

The plate is to be constructed from 150 ± 1 mm long by 100 ± 1 mm wide by 0.7 ± 0.1 mm thick austenitic nickel-based superalloy strips.

The measuring junction is to consist of nickel chromium/nickel aluminium (Type K) wire as defined in EN 60584-1, contained within mineral insulation in a heat-resisting steel alloy sheath of nominal diameter 1 mm to 3 mm, with the hot junctions electrically insulated from the sheath.

The thermocouple hot junction is to be fixed to the geometric centre of the plate in the position by a small steel strip made from the same material as the plate. The steel strip can be welded to the plate – or may be

screwed to it – to facilitate replacement of the thermocouple. The strip should be approximately 18 mm by 6 mm if it is spot-welded to the plate and nominally 25 mm by 6 mm if it is to be screwed to the plate. The screw is to be 2 mm in diameter.

The assembly of plate and thermocouple should be fitted with a pad of inorganic insulation material 97 ± 1 mm by 97 ± 1 mm by 10 ± 1 mm thick with a density of 280 ± 30 kg/m³.

EN 1363-1:2012 specifies that each plate thermometer shall be at least 100 ± 50 mm from the nearest point of the exposed face of the test construction, whereas AS 1530.4:2014 stipulates a distance of 100 ± 10 mm.

The furnace control thermocouples required by EN 1363-1:2012 are less responsive than those specified by AS 1530.4:2014. This variation in sensitivity can produce a potentially more onerous heating condition for specimens tested to EN 1363-1:2012, particularly when the furnace temperature changes quickly in the early stages of the test. Furnace temperature regime

The furnace temperature regime for fire resistance tests conducted in accordance with AS 1530.4:2014 follows the same trend as EN1363-1:2012.

The parameters outlining the accuracy of control of the furnace temperature in AS 1530.4:2014 and BS EN1363-1:2012 are not appreciably different.

5.3.3 Furnace pressure regime

It is a requirement of both AS 1530.4:2014 and EN 1363-1:2012 that for vertical elements, the furnace shall be operated so that the neutral pressure plane (a pressure of 0 Pa) is established at a height 500 mm above the notional floor level.

For wall penetrations, AS 1530.4:2014 requires that – if the separating element has a height greater than 1 m – it shall be tested with a pressure of 20 ± 3 Pa at the top of the separating element and that the horizontal penetrating services shall be included in the zone where positive pressure exceeds 10 Pa. EN 1366-3:2009 specifies that a minimum pressure of 20 Pa shall be maintained at the top of the uppermost penetration seal in a vertical supporting construction and that services shall only be included in the zone where the positive pressure exceeds 10 Pa.

Therefore, both standards require that a minimum pressure of 10 Pa be maintained at the lowest point of the lowest service.

It is a requirement of both AS 1530.4:2014 and EN 1363-1:2012 that for horizontal elements, a furnace gauge pressure of 20 Pa is established at a height 100 mm below the floor soffit level.

The parameters outlining the accuracy of control of the furnace pressure in AS 1530.4:2014 and EN 1363-1:2012 are also not appreciably different.

5.3.4 Integrity performance criteria

In accordance with AS 1530.4:2014, while a specimen maintains its insulation performance, the specimen shall be deemed to have failed the integrity criterion if it collapses or sustains flaming on the unexposed face, which can ignite a cotton pad when applied for up to 30 seconds.

A specimen shall be deemed to have failed the integrity criterion in accordance with AS 1530.4:2014 when any of the following occur:

- + Sustained flaming for 10 seconds.

- + A gap forms that allows the passage of hot gases to the unexposed face and ignites the cotton pad when applied for up to 30 seconds.
- + A gap forms that allows the penetration of a 25 mm gap gauge anywhere on the specimen.
- + A gap forms that allows a 6 mm × 150 mm gap gauge to penetrate the specimen anywhere on the specimen.

Except for minor variations the integrity criteria in EN 1363.1:2012 are generally applied in a comparable manner.

5.3.5 Specimen temperature measurement

The specimen thermocouple specification of service penetrations is generally the same for AS 1530.4:2014 and BS EN 1366-3:2009.

For the penetration construction considered. AS 1530.4:2014 specifies the following locations for thermocouples to be placed.

- + At not less than two points approximately 25 mm from the edge of the hole made for the passage of the service (one in uppermost vertical plane).
- + On the surface of the penetrating service, at least two thermocouples located approximately 25 mm from the plane of the general surface of the penetrated element (one in uppermost vertical plane).
- + At least two positions 25 mm from the interface of the separating element and main penetration seal.

For penetrating sealing systems, BS EN 1363-1:2012 specifies thermocouples are fixed in generally similar locations on the unexposed face: on the supporting construction and/or seal and on the penetrating service adjacent at the plane of penetration, and on the penetrating service some distance from the plane of penetration.

Based on the above, the effect of the differences on the thermocouple locations of the tested construction and the specifications in AS 1530.4:2014 discussed on case-by-case basis.

5.3.6 Insulation performance criteria

The general insulation criteria of AS 1530.4:2014 and BS EN 1363-1:2012 are not appreciably different.

Both AS 1530.4:2014 and BS EN 1363-1:2012 do not incorporate provisions for active fire suppression systems. Consequently, the FRL achieved by the prototype was attained without the aid of an active fire suppression system.

5.3.7 Application of test data to AS 1530.4:2014

The variations in furnace heating regimes, furnace thermocouples and the responses of the different thermocouples types to the furnace conditions are not expected to have a significant effect on the outcome of the referenced fire resistance test.

In the referenced tests, some specimens were not in accordance with AS 1530.4:2014, especially the capping arrangement of pipes. Those services were included in the assessment with the same end conditions as tested.

Based on the above discussion, it is considered that the results relating to the integrity and insulation performance of the referenced tests can be used as a basis to assess the FRL of the specimens if tested in accordance with AS 1530.4:2014.

6.0 Assessment 2 – Fire resistance performance of services penetrating Protecta FR Board

6.1 Description of variation

Various service penetrations, including metal pipes, plastic pipes and cable configurations, are tested protected with Protecta FR boards of 50 mm and 60 mm thickness with Protecta FR coating on one side (1-S) or both sides (2-S) at the aperture of the separating element. Other local protection systems such as Protecta FR acrylic and Protecta FR Wrap have also been tested in combination with the FR boards.

6.2 Methodology

The method of assessment used is summarised in Table 7.

Table 7 Method of assessment

Assessment method	
Level of complexity	Complex assessment
NCC procedure for determining fire performance	Differs in only a minor degree from a tested prototype S1C2(b) and S1C2(c)
Type of assessment	Qualitative and comparative

6.3 Assessment

6.3.1 Rigid wall constructions with wall thickness of minimum 150 mm

6.3.1.1 Cable penetration seal with two Protecta FR boards 1-S or 2-S

Penetration seal:
Cables fitted at any position within the aperture, with 60 mm thick Protecta FR Board 2-S on both sides of the wall.

Construction details:

The diagrams illustrate the construction details for cable penetration seals through a 150 mm wall. The left diagram shows three cable configurations: cable ladders with electric cables, perforated trays with electric cables, and non-perforated trays with electric cables. The right diagram shows a single cable configuration with detailed dimensions and labels for sealant, FR boards, and electric cables.

Table 8 Double side penetration seal with cables

Services	FRL
None (blank), at maximum 1200 mm × 1200 mm	-/240/240
None (blank)	-/240/180
Single electrical cables up to Ø21 mm	
Single or bundled electrical cables up to Ø21 mm, with or without trays	
Electrical cables up to Ø80 mm (single bundled and on trays)	-/180/60
Cables up to Ø21 mm in tied bundles up to Ø100 mm	-/180/120
Steel cable trays & ladders	-/180/60
Plastic conduits up to Ø16 mm	-/180/180 C/U or C/C

6.3.1.2 Cable penetration seal with 1 × 60 mm thick Protecta FR board 2-S

Penetration seal:

1. Cables (single) fitted at any position within the aperture, with Protecta FR Board 2-S positioned to either face of the wall (or anywhere in between)
2. This system may be used as a blank seal between the top of a wall and the underside of the above construction substrate. The system is applicable to concrete walls or flexible walls with a top plate to support the FR Board. The FR Board will be cut to shape and friction fitted at any position within the aperture with all edges sealed with Acrylic sealant. The substrate above may be made of any material that supports adhesion by Acrylic Sealant such as concrete, masonry, steel, gypsum, glass, plastics and any other non-porous surfaces.

Construction details:

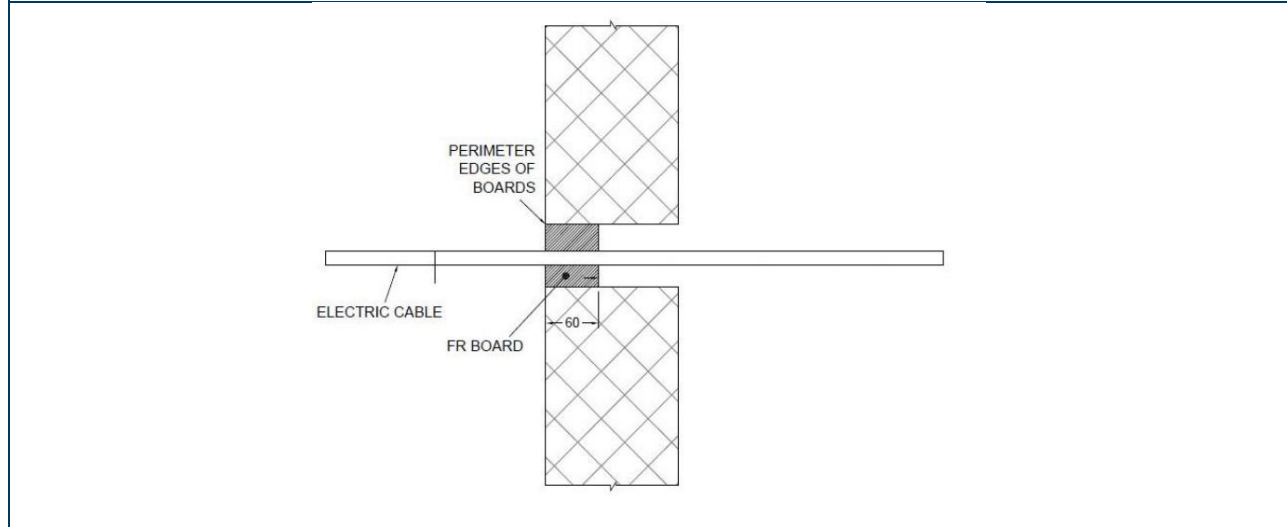

Table 9 Single side penetration seal with cables in minimum 150 mm thick walls

Services	Maximum aperture	FRL
None (blank)	As section 4.1 6	-/240/90
Single electrical cables up to Ø 21 mm		
Single A1 cable = 5 × 1.5 mm ² core HD603.3 electrical cable with PVC insulation, PVC sheath and 14 mm diameter	70 mm × 70 mm	-/240/240
Single A2 cable = 5 × 1.5 mm ² core HD22.4 electrical cable with EPR insulation, PO sheath and 11.2-14.4 mm diameter		
Single A3 cable = 5 × 1.5 mm ² core HD604.5 electrical cable with XLPE insulation, EVA sheath and 13 mm diameter		

Table 10 Single side penetration seal with cables in minimum 75 mm thick walls

Services	Maximum aperture	FRL
None (blank)	As section 4.1 10)	-/120/90
Single electrical cables up to Ø 21 mm		

6.3.1.3 Pipe penetration seal with 2 × 60 mm thick Protecta FR Board 2-S

Penetration seal:

1000 mm (min.) LI (Local interrupted) or CI (Continuous Interrupted) insulated metallic pipes (single) fitted at any position with the aperture, with 60 mm thick Protecta FR Board to both sides of the wall.

Construction details:

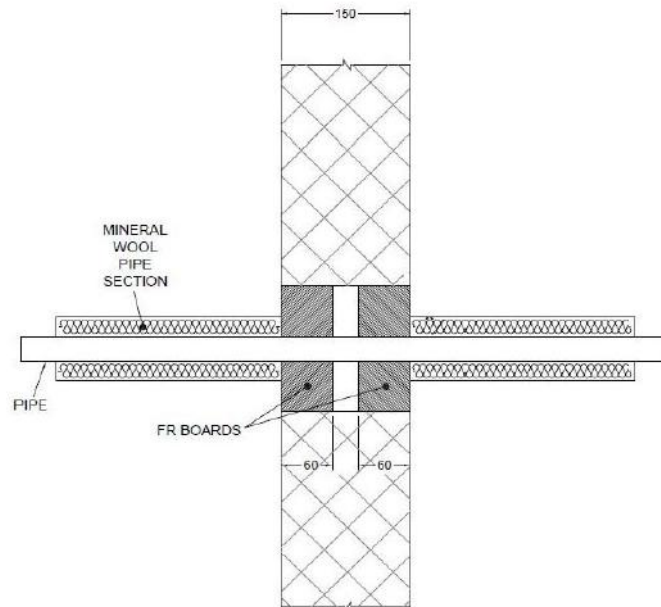

Table 11 Double side penetration seal with pipes

Services	Maximum aperture	Insulation	FRL
Mild or stainless steel			
40 mm diameter/1.5-14.2 mm wall	1200 mm × 1200 mm	20 mm Stone wool insulation 80 kg/m ³	-/240/240 C/U
40 mm diameter/1.5-14.2 mm wall*	As section 4.1 6)		-/240/180 C/U
40 mm diameter/1.5-14.2 mm wall*		30 mm stone wool insulation 80 kg/m ³	-/240/90 C/U
50 mm diameter/1.7-14.2 mm wall*			
60 mm diameter/1.9-14.2 mm wall*			
75 mm diameter/2.2-14.2 mm wall*			
90 mm diameter/2.5-14.2 mm wall*			
100 mm diameter/2.7-14.2 mm wall*			
115 mm diameter/3-14.2 mm wall*			
140 mm diameter/3.5-14.2 mm wall*			
165 mm diameter/ 3.9-14.2 mm wall*			
180 mm diameter/ 4.2-14.2 mm wall*			
200 mm diameter/ 4.6-14.2 mm wall*			
219 mm diameter/ 5.0-14.2 mm wall*			
*Note: Typical pipe diameters shown, see below graph for intermediate sizes			
Alupex composite			
16 mm diameter/2.25 mm wall	1200 mm × 1200 mm	20 mm Stone wool insulation 80 kg/m ³	-/240/240 U/C
16 mm diameter/2.25 mm wall	As section 4.1 6)		-/240/180 U/C
Copper pipe			
Up to 54 mm diameter Copper or Steel pipe 0.9-14.2 mm wall	As section 4.1 6)	20 mm Stone wool insulation 80 kg/m ³	-/240/120 C/U

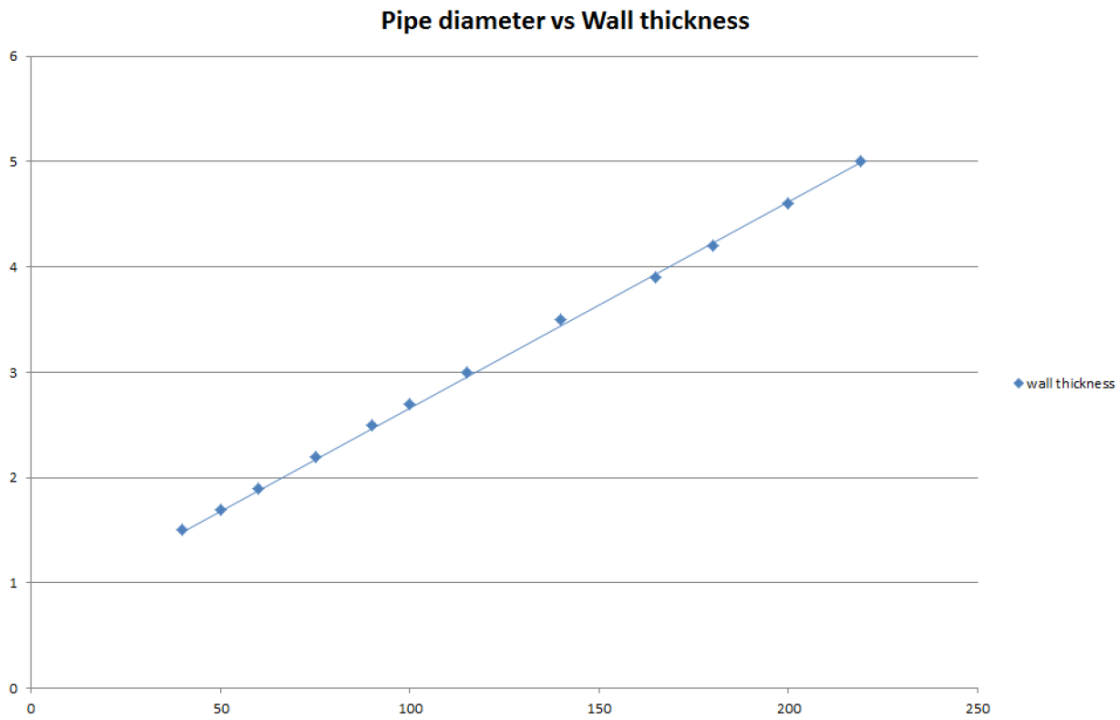

Figure 1 Intermediate pipe wall thicknesses for typical mild or stainless steel pipe diameters

6.3.1.4 Pipe penetration seal with 2 × Protecta FR Board 2-S

Penetration seal:

CS (Continuous Sustained) insulated metallic pipes fitted at any position within the aperture, with 60 mm Protecta FR Board 2-S to both sides of the wall. Minimum separation between penetration seals and seal edges of 30 mm

Construction details:

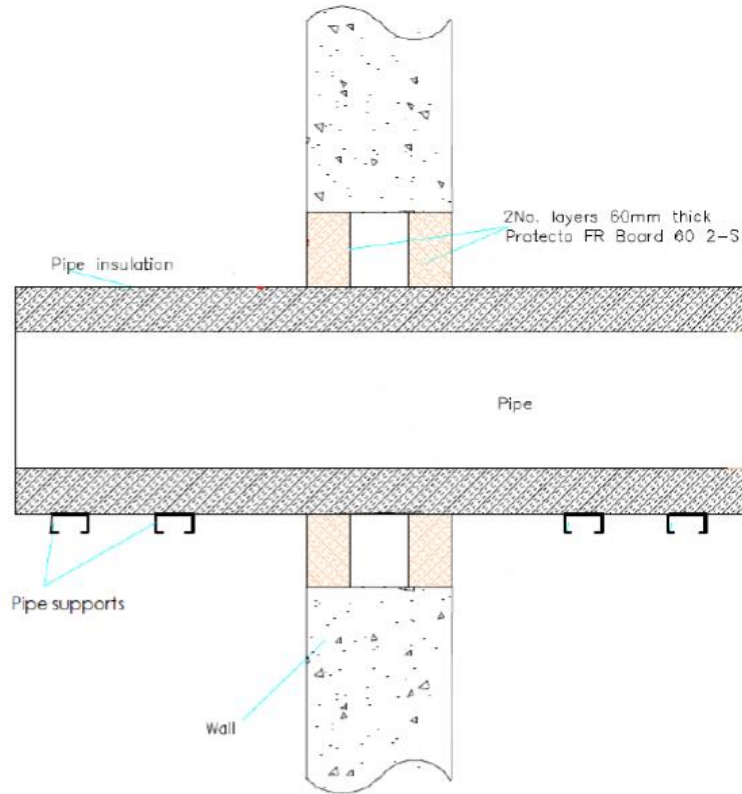

Configuration 1

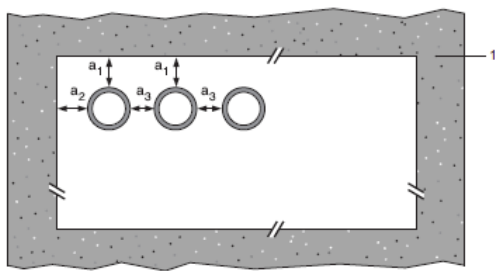

Configuration 2

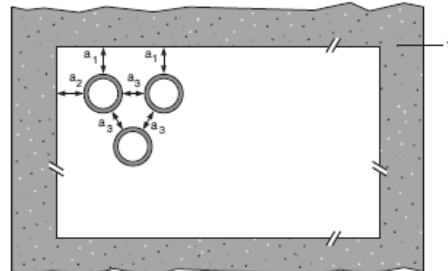

Key

- 1 Supporting construction
- a₁ Pipe/ top edge of seal separation
- a₂ Pipe/ side edge of seal separation
- a₃ Pipe/pipe separation

Table 12 Pipe penetration seal

Services	Insulation	FRL
Mild or stainless steel pipe		
40 mm diameter / 1-14.2 mm wall	20 mm thick stone or mineral wool 80 kg/m ³	-/240/180 C/U
40 mm diameter/1-14.2 mm wall*	30-80 mm thick stone or mineral wool min. 80 kg/m ³	
50 mm diameter/1.2-14.2 mm wall*		
60 mm diameter/1.4-14.2 mm wall*		
75 mm diameter/1.6-14.2 mm wall*		
90 mm diameter/1.9-14.2 mm wall*		
100 mm diameter/2.1-14.2 mm wall*		
115 mm diameter/2.4-14.2 mm wall*		
140 mm diameter/2.9-14.2 mm wall*		
165 mm diameter/ 3.4-14.2 mm wall*		
180 mm diameter/ 3.6-14.2 mm wall*		
200 mm diameter/ 4.0-14.2 mm wall*		
219 mm diameter/ 4.3-14.2 mm wall*		
250 mm diameter/ 5.0-14.2 mm wall*		
300 mm diameter/ 5.9-14.2 mm wall*		
324 mm diameter/ 6.35-14.2 mm wall*		

Pipe Diameter vs wall thickness

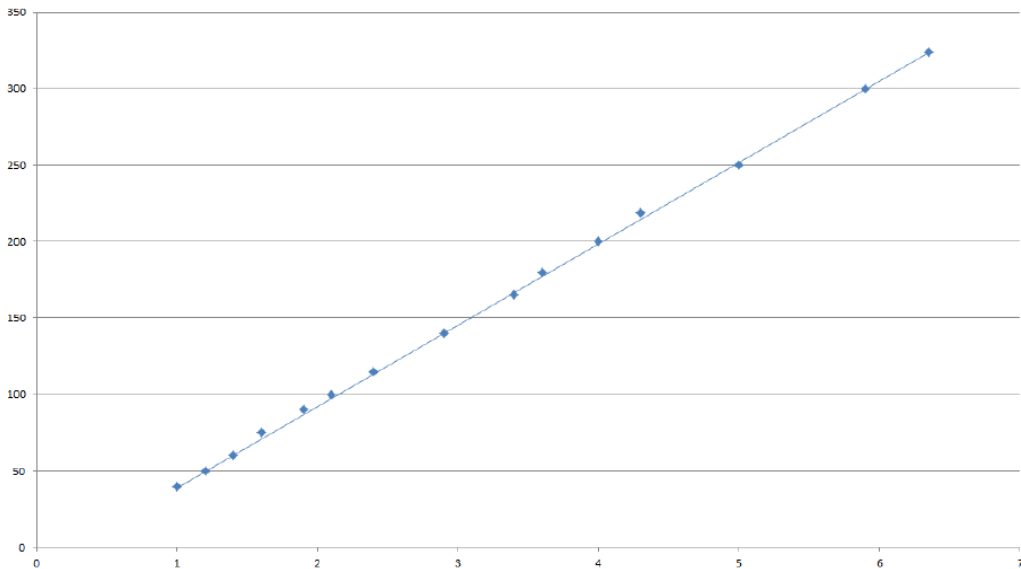

Figure 2 Intermediate pipe wall thicknesses for typical mild or stainless steel pipe diameters

6.3.1.5 Pipe penetration seal with 1 × 60 mm thick Protecta FR Board 2-S

Penetration seal:

1000 mm (min.)* LI (Local Interrupted), CI (Continuous Interrupted) or CS (continuous sustained) insulated metallic and composite pipes (single) fitted at any position within the aperture, with 60 mm Protecta FR Board to one side of the wall.

Construction details:

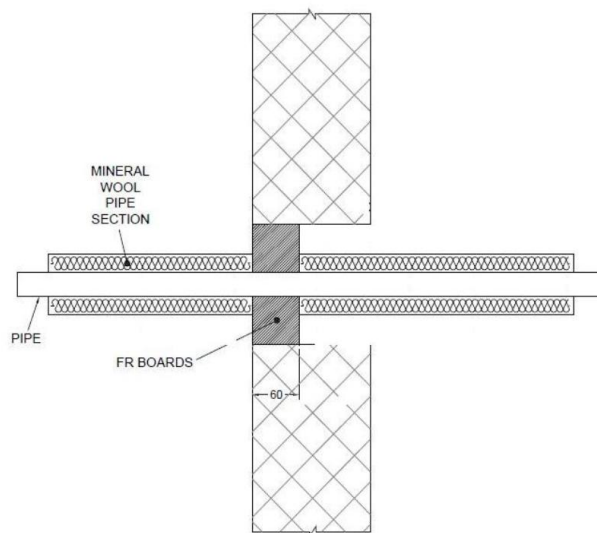

*600 mm long insulation required for Alupex pipes

Table 13 Single side penetration seal with pipes in minimum 150 mm thick walls

Services	Maximum aperture	Insulation, minimum thickness and density	FRL
Up to 12 mm diameter Copper or steel pipe 0.9-14.2 mm wall	70 mm × 70 mm	20 mm Stone wool insulation 80 kg/m ³	-240/240 C/U
Up to 54 mm diameter Copper or steel pipe 0.9-14.2 mm wall	115 mm × 115 mm		-/240/120 C/U
75 mm diameter Alupex composite pipe 7.5 mm wall	200 mm × 200 mm	30 mm Stone wool insulation 80 kg/m ³	-120/120 C/C
Up to 54 mm diameter Copper or steel pipe 0.9-14.2 mm wall	As section 4.1 6)	20 mm Stone wool insulation 80 kg/m ³	-/240/90 C/U
Up to 75 mm diameter Alupex composite pipe 7.5 mm wall		30 mm Stone wool insulation 80 kg/m ³	-/120/90 C/C
325 mm diameter Steel pipe*		-/120/90 C/U	

*Typical pipe diameters shown, see below graph for intermediate sizes

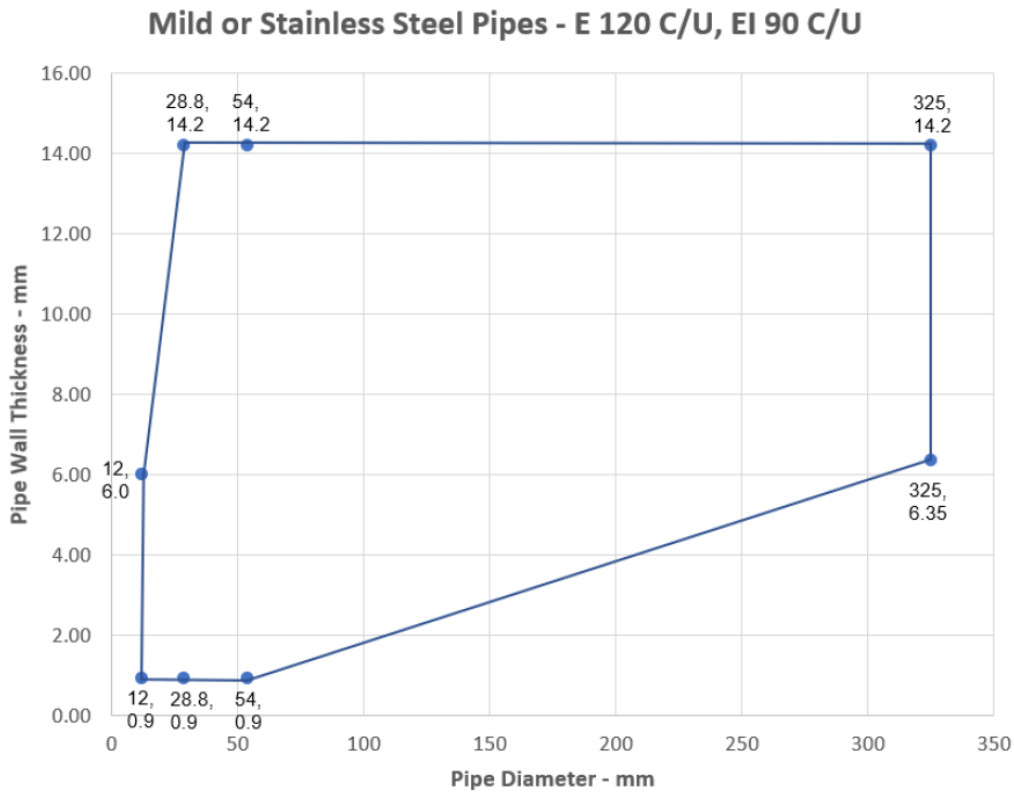

Figure 3 Intermediate pipe wall thicknesses for typical mild or stainless steel pipe diameters

Table 14 Single side penetration seal with pipes in minimum 150 mm thick walls

Services	Maximum aperture	Insulation, minimum thickness and density	FRL
Mild or stainless steel pipe			
40 mm diameter/1.5-14.2 mm wall*	280 mm × 280 mm	20 mm Stone wool insulation 80 kg/m ³	-/240/240 C/U
40 mm diameter/1.5-14.2 mm wall*		30 mm Stone wool insulation 80 kg/m ³	
50 mm diameter/1.7-14.2 mm wall*			
60 mm diameter/1.9-14.2 mm wall*			
75 mm diameter/2.2-14.2 mm wall*			
90 mm diameter/2.5-14.2 mm wall*			
100 mm diameter/2.7-14.2 mm wall*			
115 mm diameter/3-14.2 mm wall*			
140 mm diameter/3.5-14.2 mm wall*			
165 mm diameter/ 3.9-14.2 mm wall*			
180 mm diameter/ 4.2-14.2 mm wall*			
200 mm diameter/ 4.6-14.2 mm wall*			
219 mm diameter/ 5.0-14.2 mm wall*			

Services	Maximum aperture	Insulation, minimum thickness and density	FRL
40 mm diameter/1.5-14.2 mm wall*	As section 4.1 6)	20 mm Stone wool insulation 80 kg/m ³	-/240/90 C/U
50 mm diameter/1.7-14.2 mm wall*		30 mm Stone wool insulation 80 kg/m ³	
60 mm diameter/1.9-14.2 mm wall*			
75 mm diameter/2.2-14.2 mm wall*			
90 mm diameter/2.5-14.2 mm wall*			
100 mm diameter/2.7-14.2 mm wall*			
115 mm diameter/3-14.2 mm wall*			
140 mm diameter/3.5-14.2 mm wall*			
165 mm diameter/ 3.9-14.2 mm wall*			
180 mm diameter/ 4.2-14.2 mm wall*			
200 mm diameter/ 4.6-14.2 mm wall*			
219 mm diameter/ 5.0-14.2 mm wall*			
*Typical pipe diameters shown, see below graph for intermediate sizes			

Pipe diameter vs Wall thickness

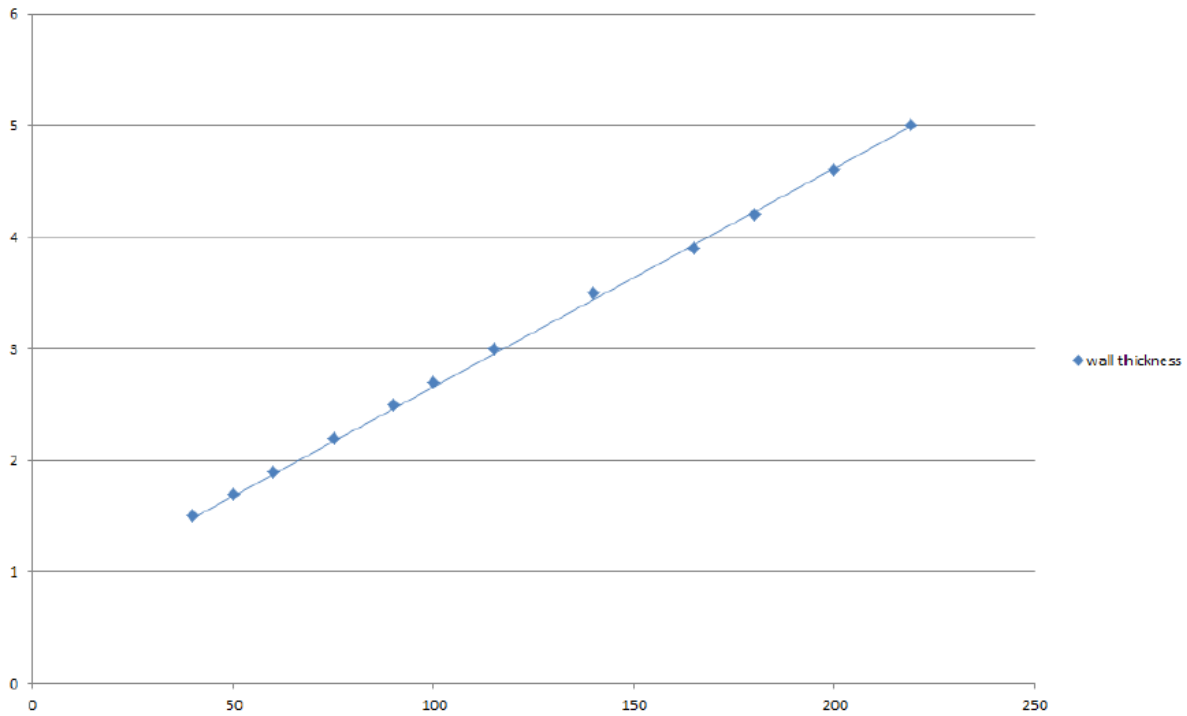

Figure 4 Intermediate pipe wall thicknesses for typical mild or stainless steel pipe diameters

Table 15 Single side penetration seal with pipes in minimum 75 mm thick walls

Services	Maximum Aperture	Insulation, minimum thickness and density	FRL
Up to 54 mm diameter Copper or steel pipe 0.9-14.2 mm wall	As section 4.1 6)	20 mm Stone wool insulation 80 kg/m ³	-/120/90 C/U
Up to 75 mm diameter Alupex composite pipe 7.5 mm wall		30 mm Stone wool insulation 80 kg/m ³	-/120/90 C/C
325 mm diameter Steel pipe*			-/120/90 C/U

*Typical pipe diameters shown, see below graph for intermediate sizes

Mild or Stainless Steel Pipes - E 120 C/U, EI 90 C/U

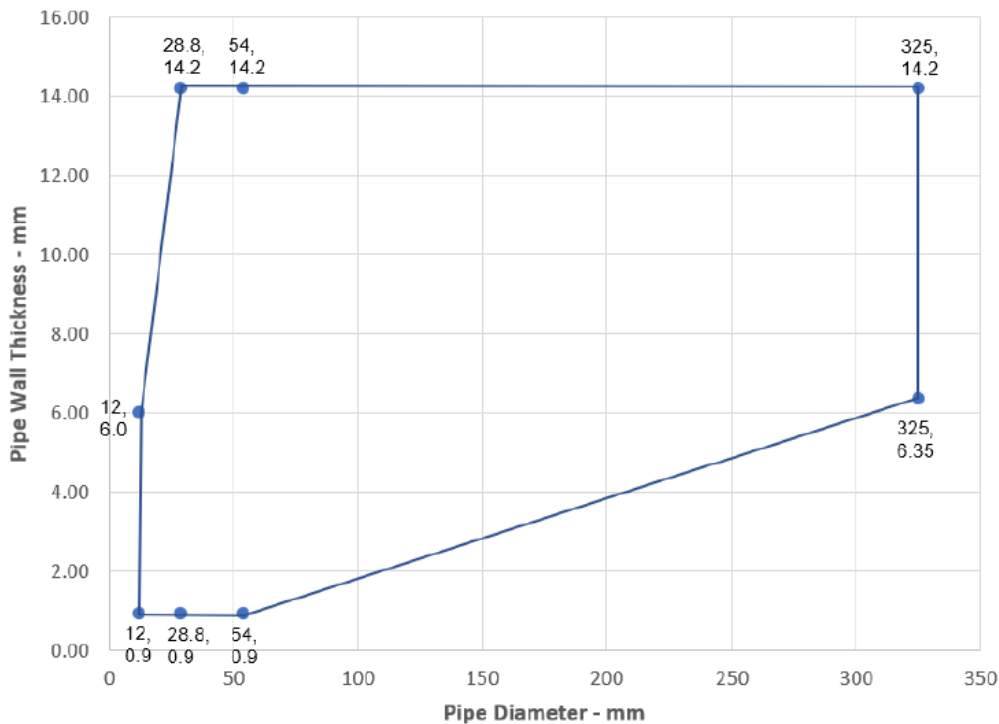

Figure 5 Intermediate pipe wall thicknesses for typical mild or stainless steel pipe diameters

Table 16 Single side penetration seal with pipes

Services	Maximum aperture	Insulation, minimum thickness and density	FRL
Mild or stainless steel pipe			
40 mm diameter/1.5-14.2 mm wall*	As section 4.1 6)	20 mm Stone wool insulation 80 kg/m ³	-/120/90 CU
50 mm diameter/1.7-14.2 mm wall*		30 mm Stone wool insulation 80 kg/m ³	
60 mm diameter/1.9-14.2 mm wall*			
75 mm diameter/2.2-14.2 mm wall*			
90 mm diameter/2.5-14.2 mm wall*			
100 mm diameter/2.7-14.2 mm wall*			
115 mm diameter/3-14.2 mm wall*			

Services	Maximum aperture	Insulation, minimum thickness and density	FRL
140 mm diameter/3.5-14.2 mm wall*			
165 mm diameter/ 3.9-14.2 mm wall*			
180 mm diameter/ 4.2-14.2 mm wall*			
200 mm diameter/ 4.6-14.2 mm wall*			
219 mm diameter/ 5.0-14.2 mm wall*			
*Typical pipe diameters shown, see below graph for intermediate sizes			

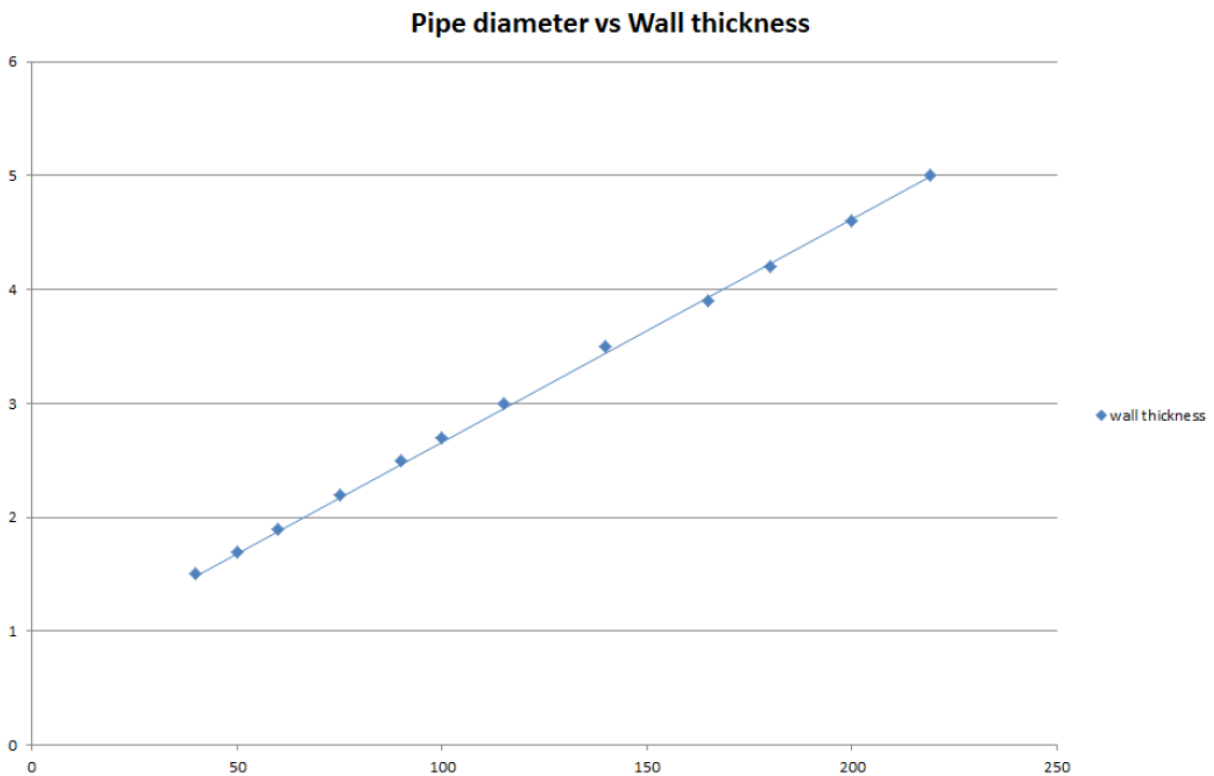

Figure 6 Intermediate pipe wall thicknesses for typical mild or stainless steel pipe diameters

6.3.1.6 Pipe penetration seal with 1 × Protecta FR Board 2-S

Penetration seal:

CS (Continuous Sustained) insulated metallic pipes fitted at any position within the aperture, with 60 mm Protecta FR Board 2-S to either side of the wall (or anywhere in between). Protecta FR Pipes Wraps are required to be fitted around combustible pipe insulation.

Construction details:

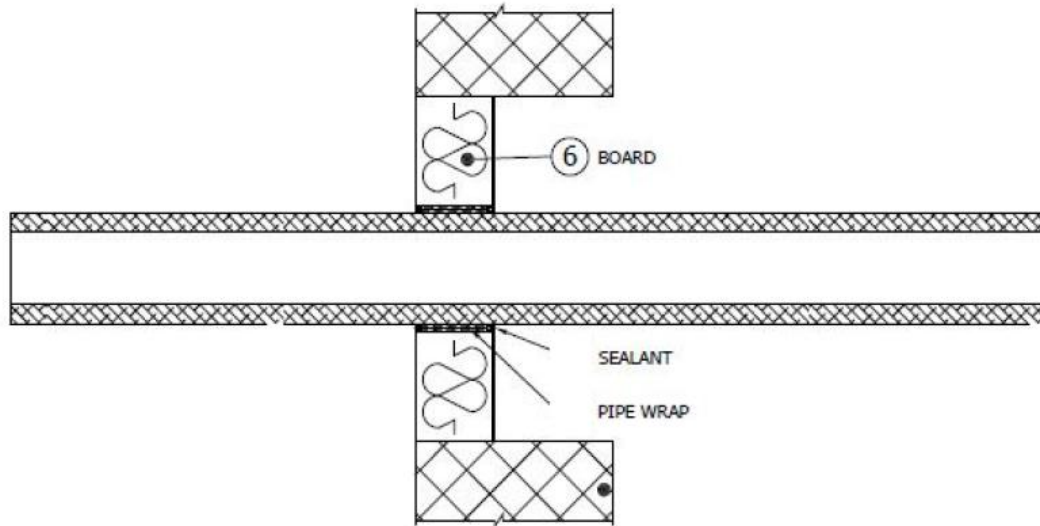

Table 17 Single side penetration seal with pipes in minimum 150 mm thick walls

Services	Wrap	Insulation	FRL
Mild or stainless steel pipe			
165 mm diameter/ 4.5-14.2 mm wall	50 mm × 1.8 mm Protecta FR Pipe Wrap fitted centrally	9-25 mm elastomeric insulation min. class B-s3, d0	-/120/30 U/C, C/U, C/C
40-219 mm diameter*	Not required	30 mm stone wool min. 80 kg/m ³	-/240/60 U/C, C/U, C/C
40-219 mm diameter*		30-50 mm stone wool min. 80 kg/m ³	-/180/60 U/C, C/U, C/C
40-325 mm diameter*		50 mm stone wool min. 80 kg/m ³	-/180/60 U/C, C/U, C/C
*Typical pipe diameters shown, see below graph for intermediate sizes			

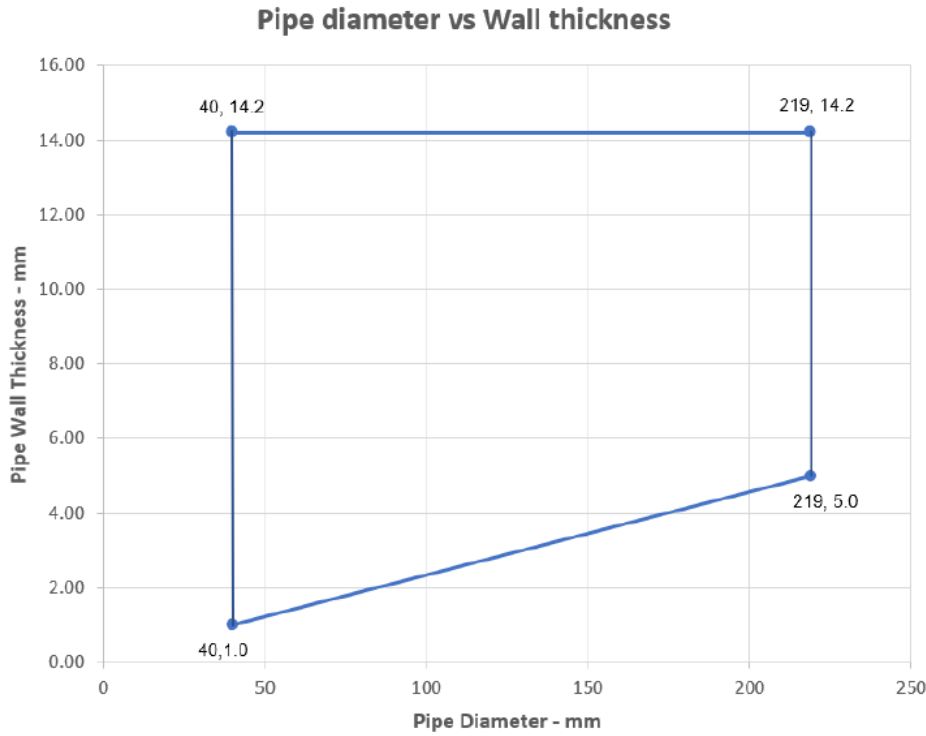

Figure 7 For 150 mm thick walls, intermediate pipe wall thicknesses for typical mild or stainless steel pipe diameters – 30 - 50 mm stone wool min. 80 kg/m³

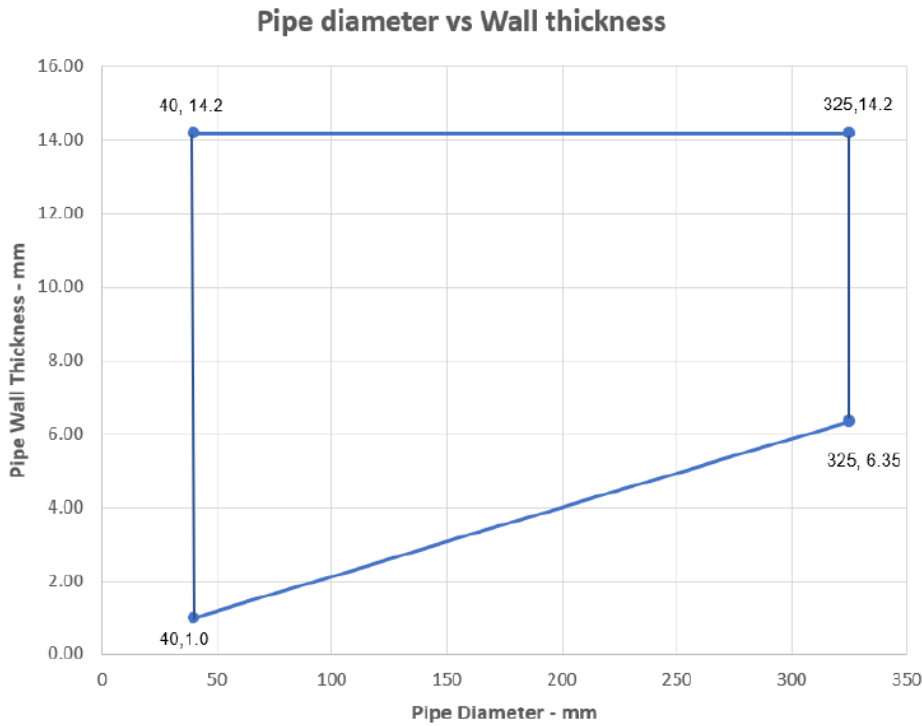

Figure 8 For 150 mm thick walls, intermediate pipe wall thicknesses for typical mild or stainless steel pipe diameters – 50 mm stone wool min. 80 kg/m³

Table 18 Single side penetration seal with pipes in minimum 75 mm thick walls

Services	Wrap	Insulation	FRL
Mild or stainless steel pipe			
165 mm diameter/ 4.5-14.2 mm wall	50 × 1.8 mm Protecta FR Pipe Wrap fitted centrally	9-25 mm elastomeric insulation min. class B-s3, d0	-/120/30 U/C, C/U, C/C
40-219 mm diameter*	Not required	30-50 mm stone wool min. 80 kg/m ³	-/120/60 U/C, C/U, C/C
40-325 mm diameter*		50 mm stone wool min. 80 kg/m ³	-/120/60 U/C, C/U, C/C
*Typical pipe diameters shown, see below graph for intermediate sizes			

Pipe diameter vs Wall thickness

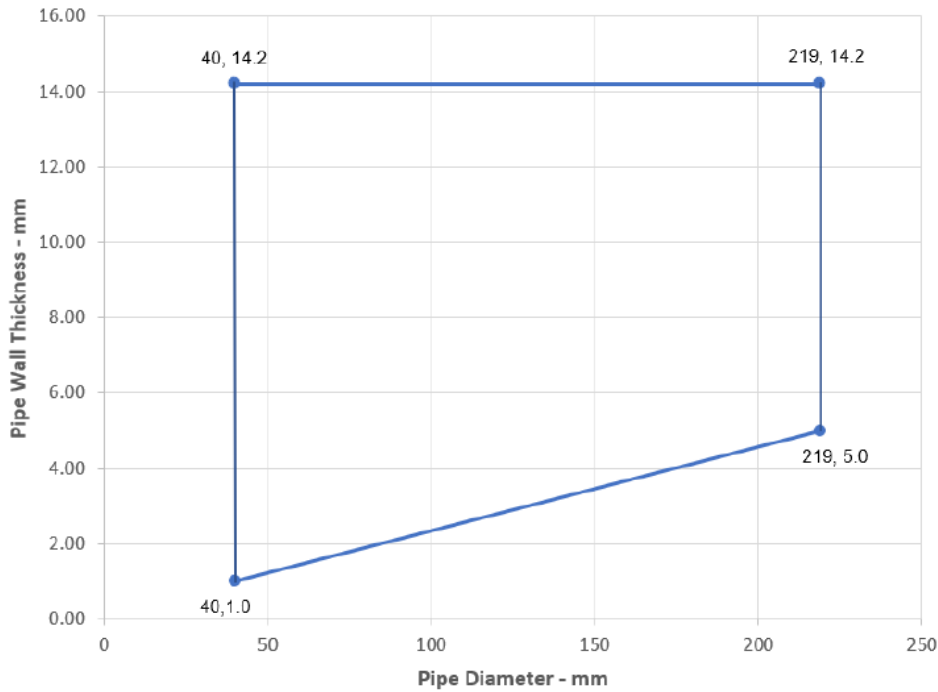

Figure 9 For 75 mm thick walls, intermediate pipe wall thicknesses for typical mild or stainless steel pipe diameters – 30 - 50 mm stone wool min. 80 kg/m³

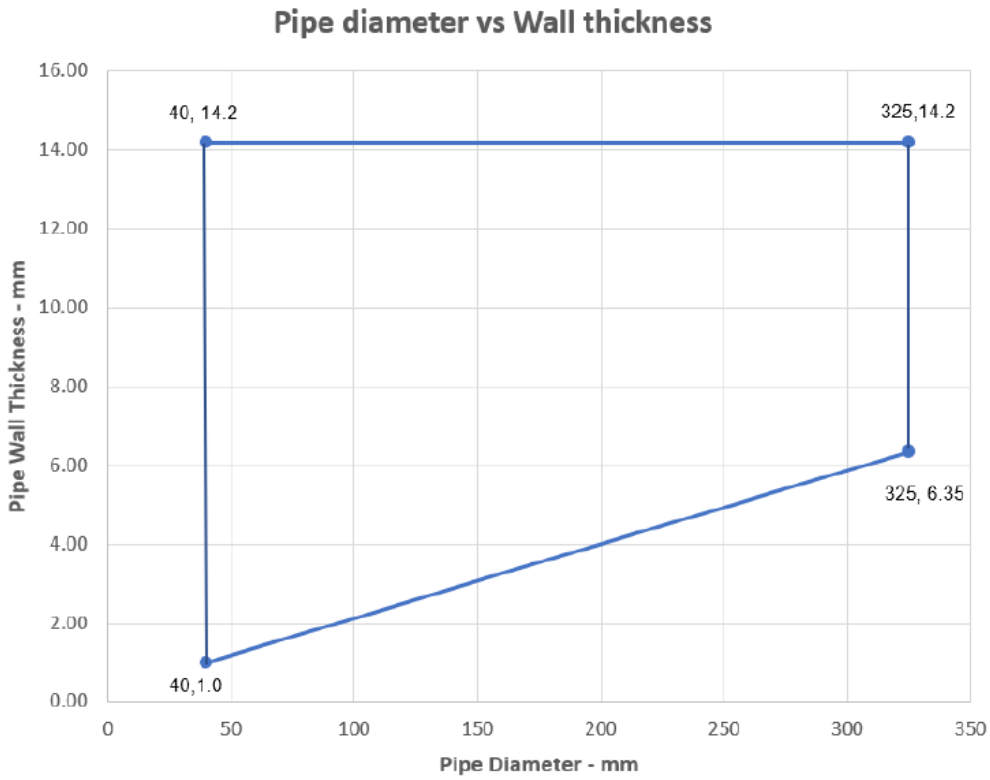

Figure 10 For 75 mm thick walls, intermediate pipe wall thicknesses for typical mild or stainless steel pipe diameters - 50 mm stone wool min. 80 kg/m³

6.3.1.7 Protecta FR Board 60 mm 2-S penetration seal (protruding) blank and with cables, in rigid wall min. 150 mm thick

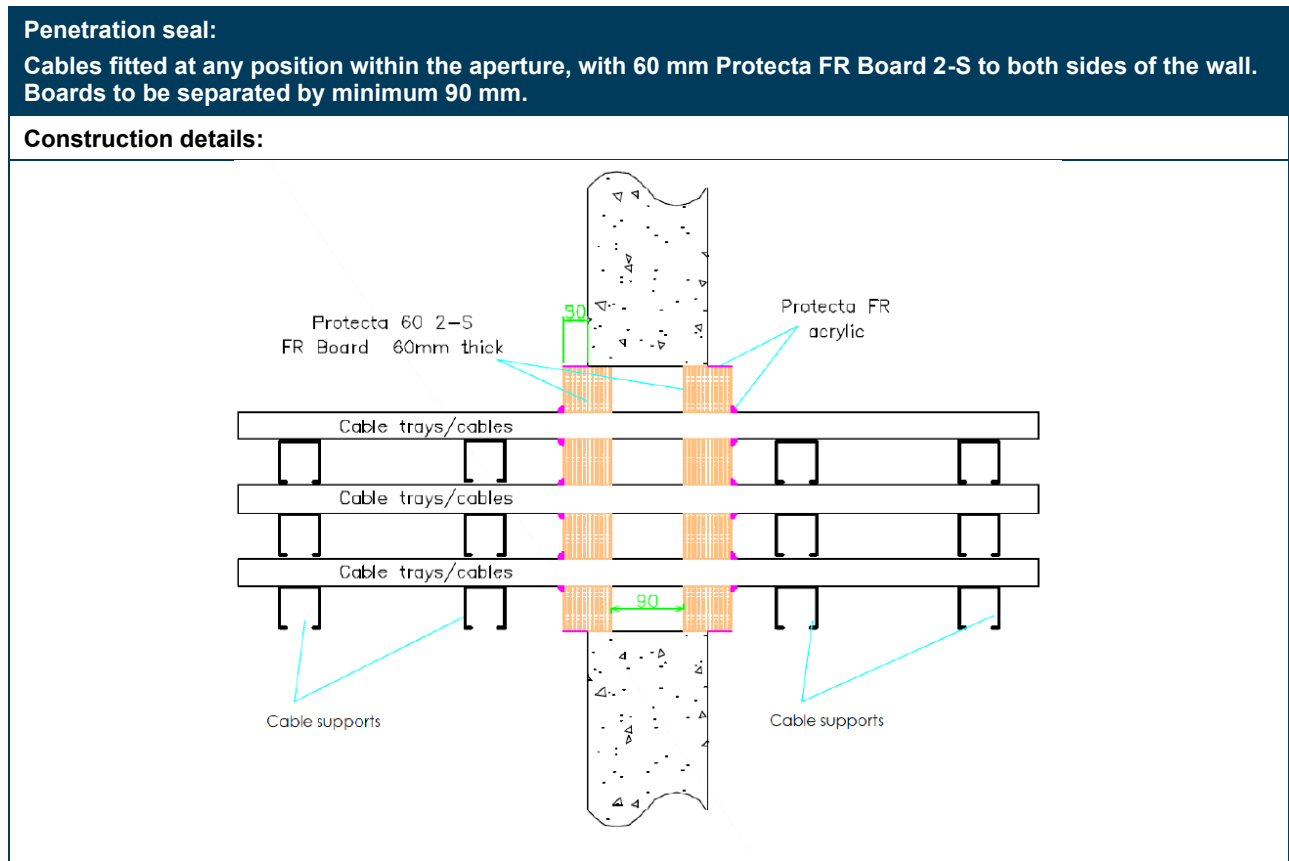

Table 19 Two side penetration seal with cables

Services	Maximum Aperture	FRL
None (blank)	600 mm wide × 600 mm high	-/240/180
Single or bundled electrical cables up to Ø 21 mm, with or without trays		-/240/120
Single or bundled electrical cables up to Ø 80 mm (single, bundled and on trays)		-/240/60
Cables up to Ø 21 mm in tied bundles up to Ø 100 mm		-/240/240
Steel Cable Trays & Ladders		-/240/180
Non-sheathed wires up to Ø 17 mm		-/240/180
Non-sheathed wires up to Ø 24 mm		-/240/90

6.3.1.8 FR Board 60 mm 2-S penetration seal (pattress) blank and with cables, in rigid wall min. 150 mm thick

Penetration seal:
 Cables fitted at any position within the aperture, with 60 mm Protecta FR Board 2-S to both sides of the wall. Boards to be pattress fixed with 100 mm steel screws and penny washers at 350 mm centres and with a minimum 50 mm overlap around the opening.

Construction details:

Table 20 Two side penetration seal with cables

Services	Maximum aperture	FRL
None (blank)	600 mm wide × 600 mm high	-/240/180
Single or bundled electrical cables up to Ø 50 mm, with or without trays		-/240/90
Single or bundled electrical cables up to Ø 80 mm (single, bundled and on trays)		-/240/60
Cables up to Ø 21 mm in tied bundles up to Ø 100 mm		-/240/240
Steel cable trays & ladders		-/240/180
Non-sheathed wires up to Ø 24 mm		-/240/120

6.3.1.9 Penetration seal with 2 × Protecta FR Board 2-S

Penetration seal:

Plastic pipes fitted at any position within the aperture, with 60 mm Protecta FR Board 2-S to both sides of the wall. Protecta FR Pipes Wraps are required to be fitted around pipes. Min. 30 mm separation between pipes in minimum 150 mm thick walls.

Construction details:

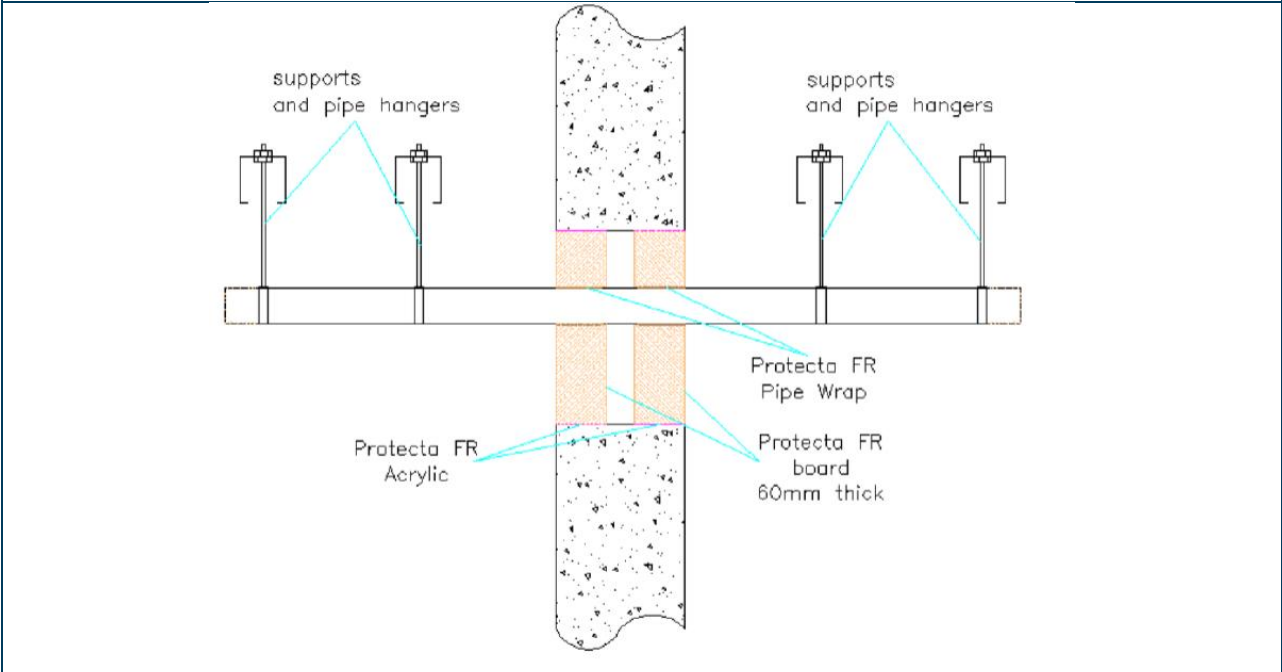

Table 21 Double side penetration seal with pipes

Services	Wrap	FRL
PVC-U pipe		
Up to 32 mm diameter / 1.0-2.4 mm wall [^]	None	-/240/240 U/C
Up to 40 mm diameter / 1.9-3.0 mm wall	50 mm × 1.8 mm	
Up to 110 mm diameter / 2.7-6.6 mm wall	50 mm × 3.6 mm	
Up to 125 mm diameter / 4.7-7.4 mm wall	50 mm × 7.2 mm	
Up to 160 mm diameter / 4.0-9.5 mm wall [*]	50 mm × 10.8 mm	-/120/120 C/C
Up to 200 mm diameter / 4.9-11.9 mm wall [*]	75 mm × 10.8 mm	-/180/180 C/C
Up to 315 mm diameter/7.7-12.1 mm wall thickness ^{*#}	75 mm × 18 mm	-/120/120 C/C
Up to 400 mm diameter/9.8-15.3 mm wall thickness ^{*#}	75 mm × 28.8 mm	-/120/120 C/C
Diameter up to Ø 32 mm, wall thickness 1.0-2.4 mm in pipe bundles up to Ø 107 mm ¹⁾	50 mm × 3.6 mm	-/240/240 U/C
PE pipe		
Up to 40 mm diameter / 2.4-4.6 mm wall	50 mm × 1.8 mm	-/240/240 U/C
Up to 110 mm diameter / 3.4-10.0 mm wall	50 mm × 3.6 mm	
Up to 125 mm diameter / 3.9-7.4 mm wall	50 mm × 7.2 mm	
Up to 160 mm diameter / 4.9-9.5 mm wall [*]	50 mm × 10.8 mm	
Up to 200 mm diameter / 4.9-18.2 mm wall [*]	75 mm × 10.8 mm	-/180/180 C/C

Services	Wrap	FRL
Up to 315 mm diameter / 28.6 mm wall thickness*#	75 mm × 18 mm	-/180/120 C/C
Up to 400 mm diameter/ 36.3 mm wall thickness*#	75 mm × 28.8 mm	-/120/120 C/C
Diameter up to Ø 32 mm, wall thickness 2.0-4.4 mm in pipe bundles up to Ø 107 mm ¹⁾	50 mm × 3.6 mm	-/240/240 C/U
PP pipe		
Up to 40 mm diameter / 1.8-5.5 mm wall	50 mm × 1.8 mm	-/240/240 U/C
Up to 110 mm diameter / 2.7-10.0 mm wall	50 mm × 3.6 mm	-/240/240 C/C
Up to 125 mm diameter / 3.1-11.4 mm wall	50 mm × 7.2 mm	
Up to 160 mm diameter / 4.9-14.6 mm wall	50 mm × 10.8 mm	
Up to 200 mm diameter / 4.9-18.2 mm wall	75 mm × 10.8 mm	-/180/180 C/C
Diameter up to Ø 32 mm, wall thickness 1.8-4.4 mm in pipe bundles up to Ø 107 mm ¹⁾	50 mm × 3.6 mm	-/240/240 C/U
1) PVC, PE and PP pipes can be mixed in the same bundle. * Typical pipe diameters shown, see below graph for intermediate sizes. # Configuration 1 & 2 ^Sealed with a bead of Protecta FR Acrylic applied flush to the pipe and batt on the outer faces of the board		

PVC-U Pipes - EI 120 C/C

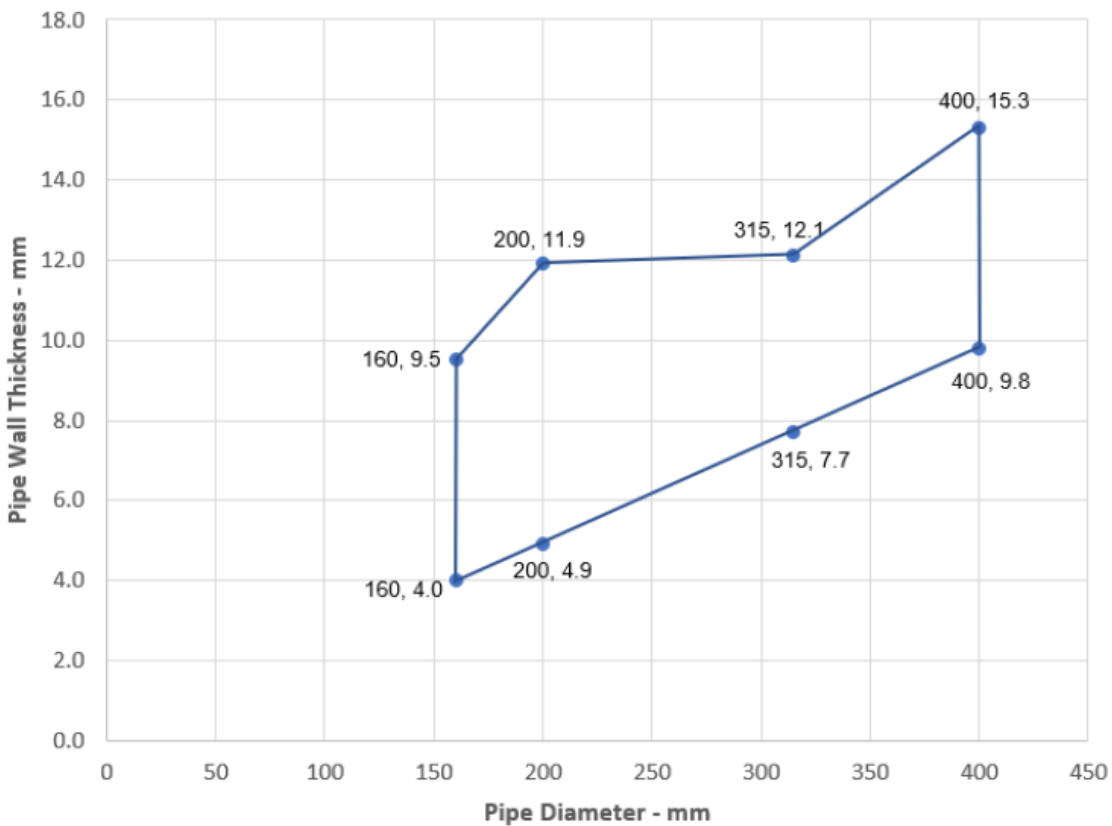

Figure 11 Intermediate pipe wall thicknesses for typical PVC-U diameters

6.3.2 Rigid floor constructions according to section 4.1 2) with floor thickness of minimum 150 mm

6.3.2.1 Cable penetration seal with 2 × Protecta FR Board 2-S

Penetration seal:
Cables fitted at any position within the aperture, with 60 mm Protecta FR Board 2-S to both sides of the floor.

Construction details:

Table 22 Double side penetration seal with cables

Services	Maximum aperture	FRL
None (blank)	1200 mm × 600 mm	-/180/180
None (blank)	2400 mm × 1200 mm	-/180/120
Electrical Cables up to Ø 21 mm (single, bundled and on trays)		-/120/120
Electrical Cables up to Ø 80 mm (single, bundled and on trays)		-/120/60
Cables up to Ø 21 mm in tied bundles up to Ø 100 mm		-/120/120
Steel Cable trays & Ladders		-/120/60
Non- sheathed wires up to Ø 24 mm		-/180/30
Plastic conduits up to Ø 16 mm		-/120/90 C/U, C/C

6.3.2.2 Cable penetration seal with 1 × Protecta FR Board 2-S

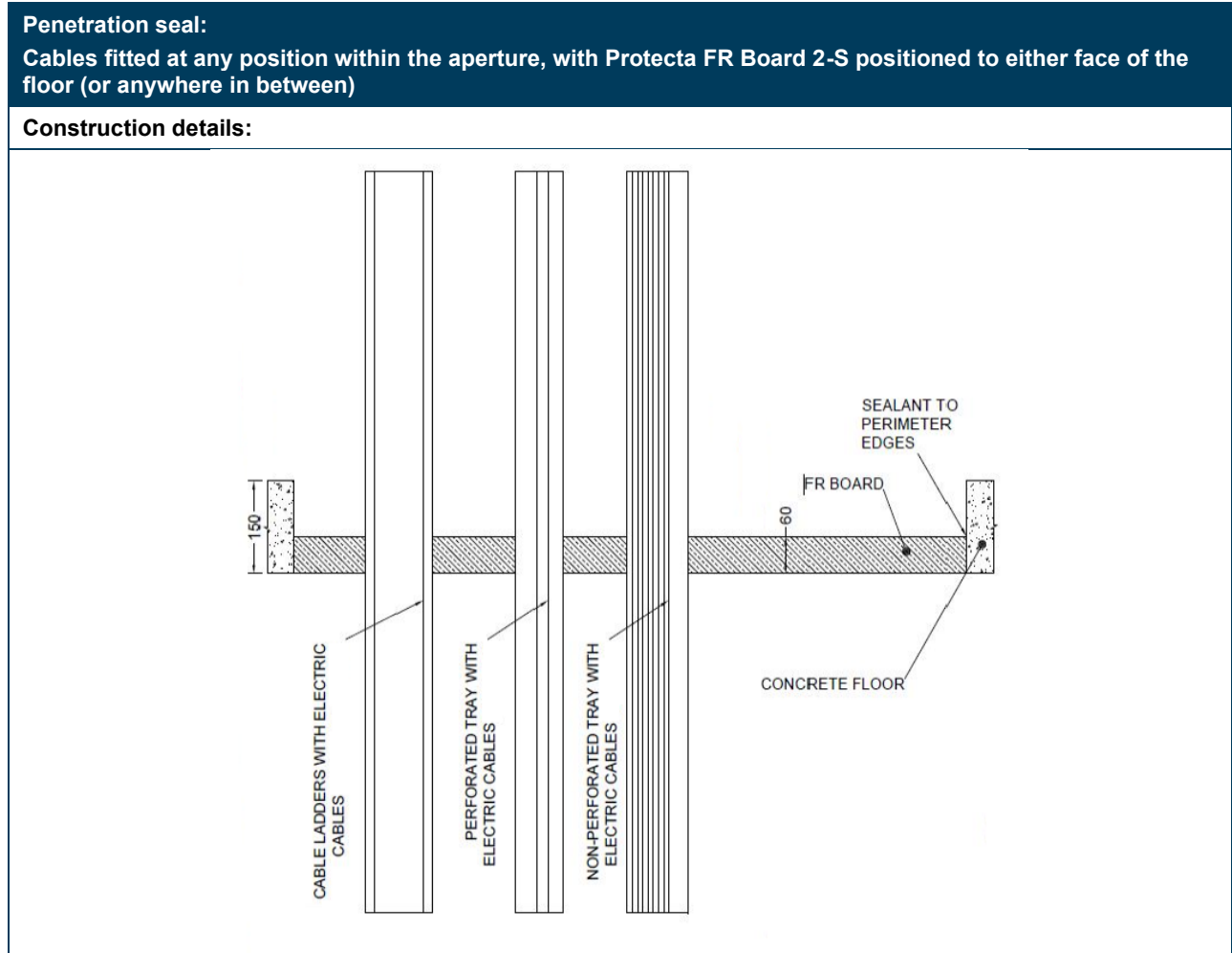

Table 23 Single side penetration seal with cables

Services	Maximum aperture	FRL
None (blank)	1200 mm × 600 mm	-/240/120
None (blank)	2400 mm × 1200 mm	-/120/90
Single* electrical cables up to Ø 21 mm		-/120/30
Single* electrical cables up to Ø 21 mm	600 mm × 1200 mm	-/240/30
Electrical cables up to Ø 21 mm (single, bundled and on trays)	2400 mm × 1200 mm	-/90/30
Electrical cables up to Ø 80 mm (single, bundled on and trays)		-/90/30
Cables up to Ø 21 mm in tied bundles up to Ø 100 mm		-/30/30
Steel Cable trays & Ladders		-/30/30
Non-Sheathed wires up to Ø 17 mm		-/30/30
Non-Sheathed wires up to Ø 24 mm		-/30/-
Plastic conduits up to Ø 16 mm		-/30/30 C/U C/C
Steel or copper conduit up to Ø 16 mm		-/30/- C/U

6.3.2.3 Pipe penetration seal with 2 × Protecta FR Board 2-S

Penetration seal:
 1000 mm (min.) LI (Local interrupted) or CI (Continuous interrupted) insulated metallic pipes (single) fitted at any position within the aperture, with 2 layers of 60 mm Protecta FR Board 2-S together within the floor

Construction details:

Table 24 Two-layer penetration seal with pipes

Services	Maximum aperture	Insulation	FRL
Mild or stainless steel pipe			
40 mm diameter/1.5-14.2 mm wall*	1200 mm × 600mm	20 mm stone wool insulation 80 kg/m ³	-/180/180 C/U
40 mm diameter/1.5-14.2 mm wall*	280 mm × 280 mm		-/240/240 C/U
40 mm diameter/1.5-14.2 mm wall	2400 mm × 1200 mm		-/180/120 C/U
40 mm diameter/1.5-14.2 mm wall*		30 mm Stone wool insulation 80 kg/m ³	-/180/60 C/U
50 mm diameter/1.7-14.2 mm wall*			
60 mm diameter/1.8-14.2 mm wall*			
75 mm diameter/2.1-14.2 mm wall*			
90 mm diameter/2.3-14.2 mm wall*			
100 mm diameter/2.5-14.2 mm wall*			
115 mm diameter/2.8-14.2 mm wall*			
140 mm diameter/3.2-14.2 mm wall*			
165 mm diameter/ 3.6-14.2 mm wall*			
180 mm diameter/ 3.9-14.2 mm wall*			
200 mm diameter/ 4.2-14.2 mm wall*			

Services	Maximum aperture	Insulation	FRL
219 mm diameter/ 4.5-14.2 mm wall*			
Note: *Typical pipe diameters shown, see below graph for intermediate sizes			

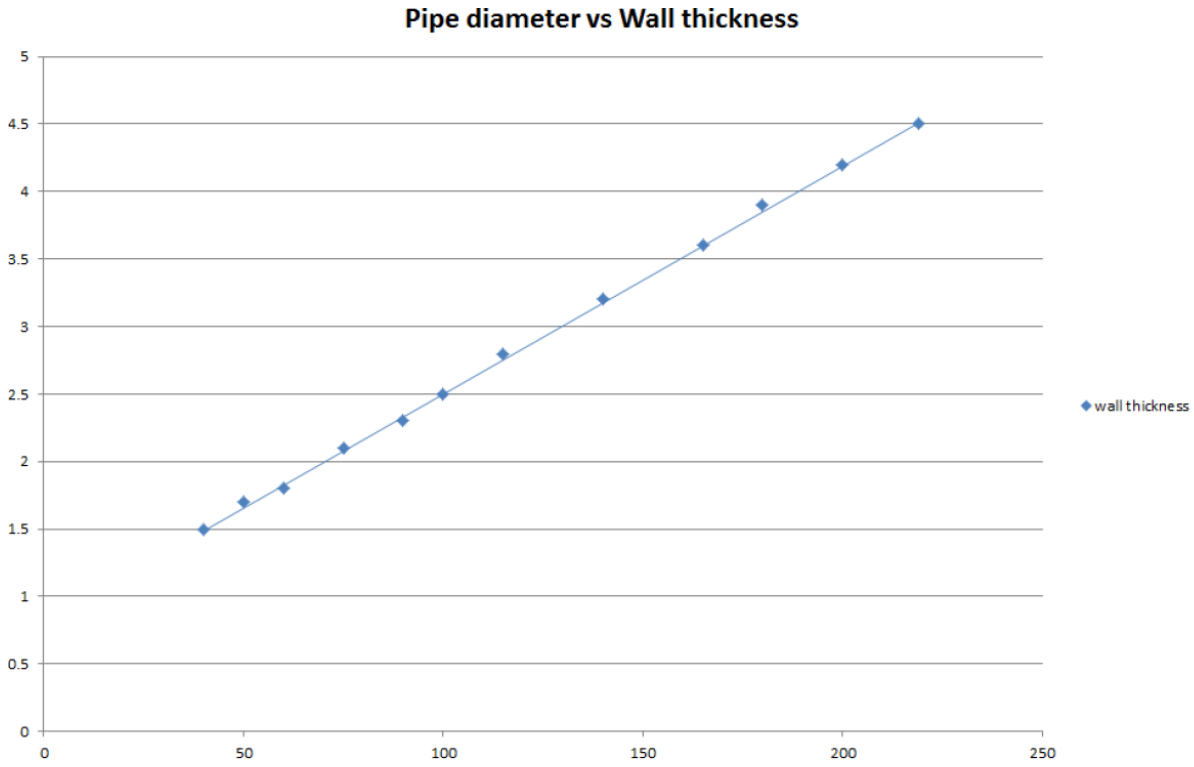

Figure 12 Intermediate pipe wall thicknesses for typical mild or stainless steel pipe diameters

6.3.2.4 Metal pipe penetrations with one Protecta FR board 1-S or 2-S and continuous interrupted insulation

Penetration seal:
 1000 mm (min.)* LI (Local interrupted) or CI (Continuous interrupted) insulated metallic pipes (single) fitted at any position within the aperture, with 60 mm Protecta FR Board 2-S to either side of the floor (or anywhere in between)

Construction details:

Table 25 Single side penetration seal with pipes

Services	Maximum aperture	Insulation	FRL
Up to 12 mm diameter Copper pipe 0.9-14.2 mm	1200 mm × 600mm	20 mm Stone wool insulation 80 kg/m ³	-/240/30 C/U
Up to 54 mm diameter Copper pipe 0.9-14.2 mm wall	1200 mm × 600 mm		-/240/240 C/U
	2400 mm × 1200 mm	-/120/120 C/U	
114 mm diameter mild or Stainless Steel pipe 11-14.2 mm wall	600 mm × 1200 mm	None	-/240/- C/C
	2400 mm × 1200 mm		-/120/-C/C
Mild or stainless steel pipe			
40 mm diameter/ 1.5-14.2 mm wall*	600 mm × 1200 mm	20 mm Stone wool Insulation 80 kg/m ³	-/240/60 C/U
40 mm diameter/ 1.5-14.2 mm wall*			-/240/90 C/U
50 mm diameter/ 1.7-14.2 mm wall*			

Services	Maximum aperture	Insulation	FRL
60 mm diameter/ 1.8-14.2 mm wall*			
75 mm diameter/ 2.1-14.2 mm wall*			
90 mm diameter/ 2.3-14.2 mm wall*			
100 mm diameter/ 2.5-14.2 mm wall*			
115 mm diameter/ 2.8-14.2 mm wall*			
140 mm diameter/ 3.2-14.2 mm wall*			
165 mm diameter/ 3.6-14.2 mm wall*			
180 mm diameter/ 3.9-14.2 mm wall*			
200 mm diameter/ 4.2-14.2 mm wall*			
219 mm diameter/ 4.5-14.2 mm wall*			
40 mm diameter/ 1.5-14.2 mm wall*	2400 mm wide by 1200 mm high	20mm Stone wool insulation 80 kg/m ³	-/120/60 C/U
40 mm diameter/ 1.5-14.2 mm wall*		30mm Stone wool insulation 80 kg/m ³	-/120/90 C/U
50 mm diameter/ 1.7-14.2 mm wall*			
60 mm diameter/ 1.8-14.2 mm wall*			
75 mm diameter/ 2.1-14.2 mm wall*			
90 mm diameter/ 2.3-14.2 mm wall*			
100 mm diameter/ 2.5-14.2 mm wall*			
115 mm diameter/ 2.8-14.2 mm wall*			
140 mm diameter/ 3.2-14.2 mm wall*			
165 mm diameter/ 3.6-14.2 mm wall*			
180 mm diameter/ 3.9-14.2 mm wall*			
200 mm diameter/ 4.2-14.2 mm wall*			
219 mm diameter/ 4.5-14.2 mm wall*			
Typical pipe diameters shown, see below graph for intermediate sizes			

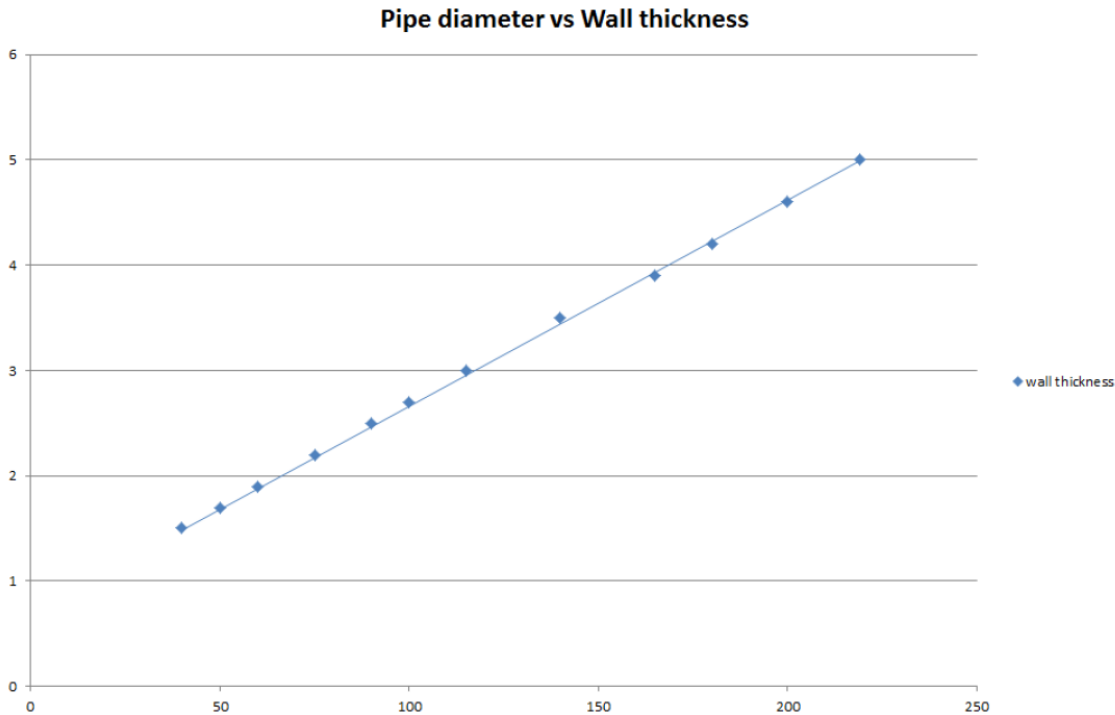

Figure 13 Intermediate pipe wall thicknesses for typical mild or stainless steel pipe diameters

Table 26 Single side penetration seal with pipes

Services	Maximum aperture	Insulation (minimum)	FRL
Geberit Mepla MLC (PE-Xb/Aluminium/PE-HD pipe)			
16 mm diameter/2.25 mm wall	75 mm × 75 mm	500 mm long, 20 mm Stone wool insulation 80 kg/m ³	-/240/180 C/C
16 mm diameter/2.25 mm wall	600 mm × 1200 mm		-/240/90 C/C
20 mm diameter/2.5 mm wall			
26 mm diameter/ 3mm wall			
32 mm diameter/ 3mm wall			
40 mm diameter/ 3.5 mm wall			
50 mm diameter/ 4mm wall			
63 mm diameter/ 4.5 mm wall			
75 mm diameter/ 4.7 mm wall			
16 mm diameter/ 2.25 mm wall	2400 mm × 1200 mm		-/120/90 C/C
20 mm diameter/ 2.5 mm wall			
26 mm diameter/ 3 mm wall			
32 mm diameter/ 3 mm wall			
40 mm diameter/ 3.5 mm wall			
50 mm diameter/ 4 mm wall			

Services	Maximum aperture	Insulation (minimum)	FRL
63 mm diameter/ 4.5 mm wall			
75 mm diameter/ 4.7 mm wall			

6.3.2.5 Pipe penetration seal with 1 × Protecta FR Board 2-S

Penetration seal:
 Combustible pipes fitted at any position within the aperture, with 50 mm Protecta FR Board 2-S at mid-depth of the floor. Protecta FR Pipes Wraps are required to be fitted around combustible pipe insulation. Maximum aperture size 2400 mm × 1200 mm

Construction details:

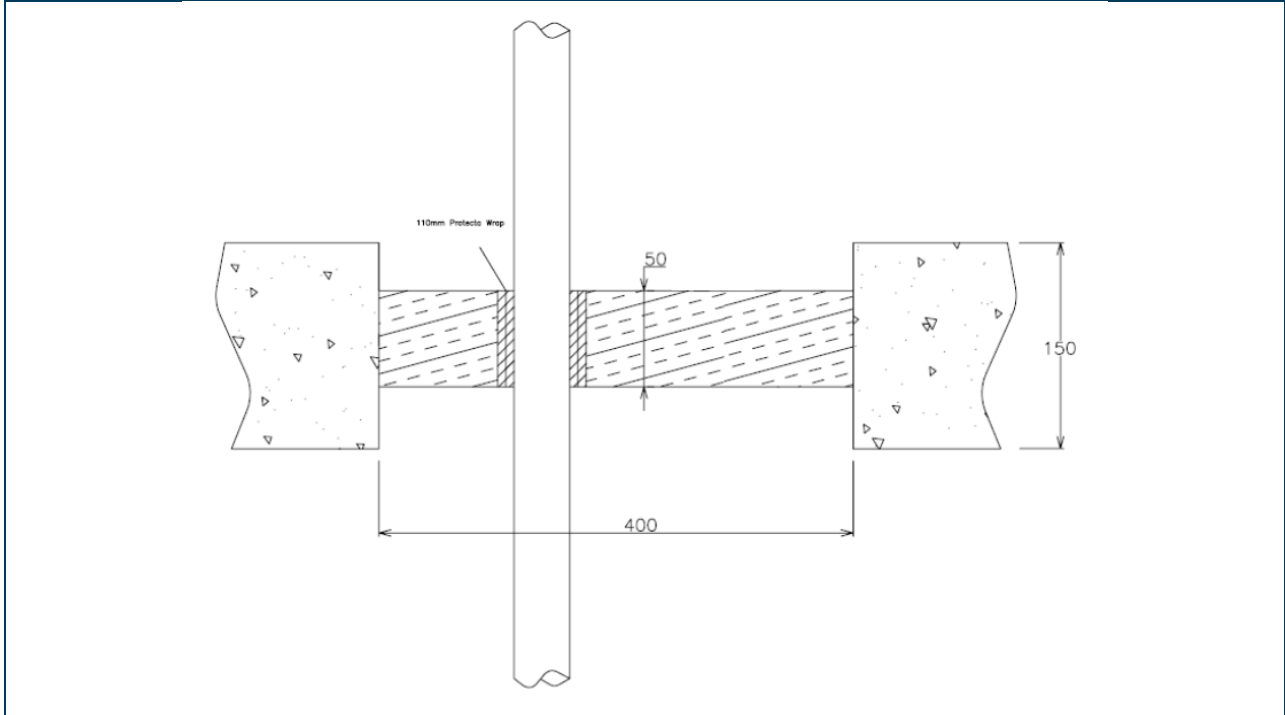

Table 27 Central penetration seal with pipes

Services	Wrap	FRL
PVC-U pipe		
110 mm diameter/ 3.4 mm wall	50 mm × 3.6 mm Protecta FR Pipe Wrap	-/90/90 C/C

6.3.2.6 Pipe penetration seal with 1 × Protecta FR Board 2-S

Penetration seal:

CS (continuous sustained) insulated metallic pipes fitted at any position within the aperture, with 60 mm Protecta FR Board 2-S to either side of the floor (or anywhere in between). Protecta FR Pipe wraps are required to be fitted around the combustible pipe insulation. Maximum aperture size 2400 mm × 1200 mm

Construction details:

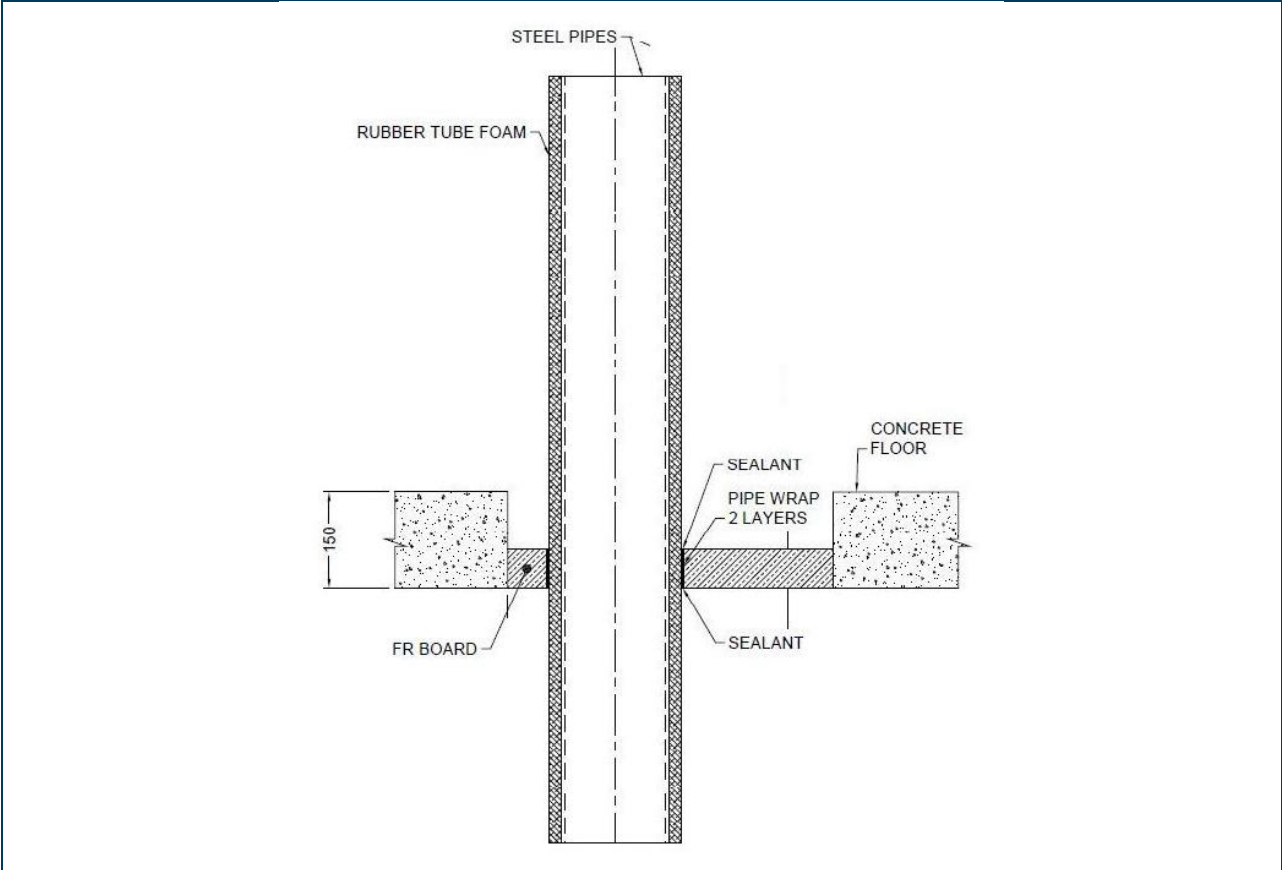

Table 28 Single side penetration seal with pipes

Services	Wrap	Insulation	FRL
Mild or stainless steel pipe			
165 mm diameter/ 4.5-14.2 mm wall	50 mm × 3.6 mm Protecta FR Pipe Wrap fitted at bottom of seal	13 mm elastomeric insulation min. class B-s3, d0	-/90/30 C/U
		19 mm elastomeric insulation min. class B-s3, d0	-/90/90 C/U
	Not required	25-40 mm stone wool 80 kg/m ³	-/90/60 C/U

6.3.2.7 Pipe penetration seal with 2 × Protecta FR Board 2-S

Penetration seal:

CS (Continuous Sustained) insulated metallic pipes fitted at any position within the aperture, with 60 mm Protecta FR Board 2-S to both sides of the floor. Protecta FR Pipes Wraps are required to be fitted around combustible pipe insulation at the soffit. Maximum aperture size 2400 mm × 1200 mm

Construction details:

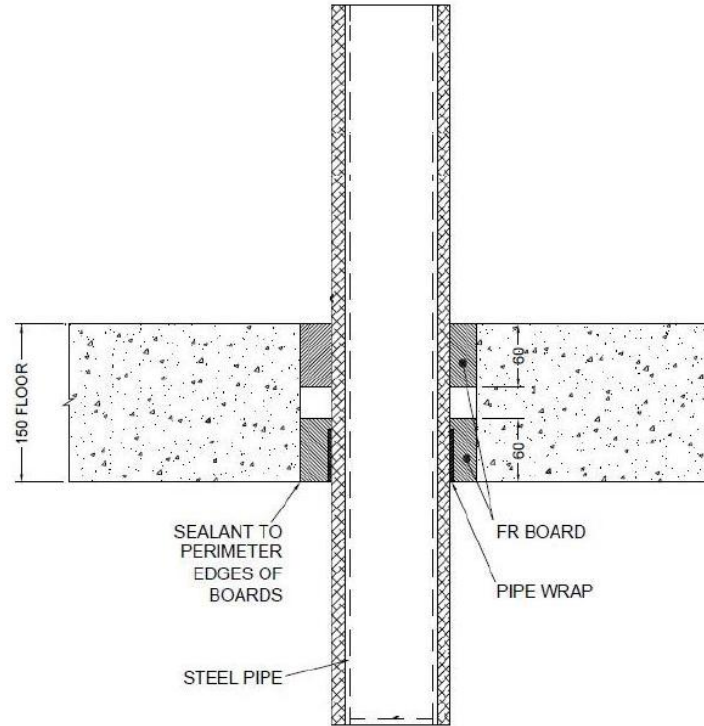

Table 29 Double side penetration seal with pipes

Services	Wrap	Insulation	FRL
Mild or stainless steel pipe			
40 mm diameter/ 1-14.2 mm wall	50 mm × 1.8 mm Protecta FR Pipe Wrap	13 mm elastomeric insulation min. class B-s3, d0	-/180/120 C/U

6.3.2.8 Pipe penetration seal with 2 × Protecta FR Board 2-S (back to back)

Penetration seal:
 CS (Continuous Sustained) insulated metallic and composite pipes fitted at any position within the aperture, with two layers of 60 mm Protecta FR Board 1-S installed together to either side of the floor (or anywhere in between). Protecta FR Pipe Wraps are required to be fitted around combustible pipe insulation at the bottom of the seal. Maximum aperture size 2400 mm × 1200 mm

Construction details:

Table 30 Back to back penetration seal with pipes

Services	Wrap	Insulation	FRL
Copper pipe			
12-54 mm diameter/ 1-1.2 mm wall	50 mm × 3.6 mm Protecta FR Pipe Wrap fitted to both sides of the seal	9-13 mm elastomeric insulation min. class B-s3, d0	-/240/60 C/C
12-54 mm diameter/1-1.2 mm wall		13-25 mm elastomeric insulation min. class B-s3, d0	-/180/45 C/C

Services	Wrap	Insulation	FRL
Geberit Mepla MLC (PE- Xb/ Aluminium/ PE-HD pipe)			
16 mm diameter/2.25 mm wall	50 mm × 3.6 mm Protecta FR Pipe Wrap fitted to both sides of the seal	9-13 mm elastomeric insulation min. class B-s3, d0min. class B-s3, d0	-/120/120 C/C
20 mm diameter/2.5 mm wall			
26 mm diameter/3 mm wall			
32 mm diameter/3 mm wall			
40 mm diameter/3.5 mm wall			
50 mm diameter/4 mm wall			
63 mm diameter/4.5 mm wall			
75 mm diameter/4.7 mm wall			
16 mm diameter/2.25 mm wall		13-25 mm elastomeric insulation min. class B-s3, d0	-/60/45 C/C
20 mm diameter/2.5 mm wall			
26 mm diameter/3 mm wall			
32 mm diameter/3 mm wall			
40 mm diameter/3.5 mm wall			
50 mm diameter/4 mm wall			
63 mm diameter/4.5 mm wall			
75 mm diameter/4.7 mm wall			

6.3.3 Timber floor constructions according to section 4.1 2 with floor thickness of 150 mm

6.3.3.1 Cable penetration seal with 2 × Protecta FR Board 1-S

Penetration Seal:
 Cables fitted at any position within the aperture, with two layers of 50 mm Protecta FR Board 1-S within the floor with the coated side downwards. The external board layer has a minimum 100 mm overall all around the aperture.

Construction details

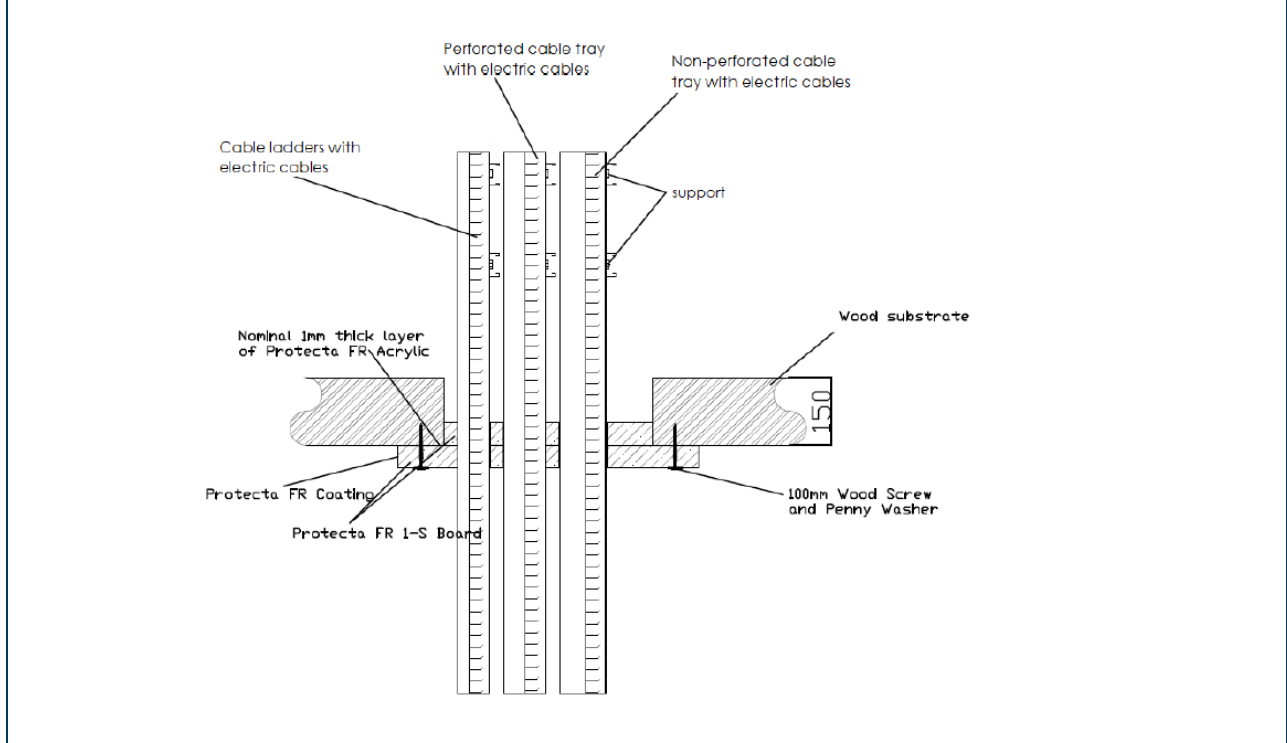

Note: Density must be minimum 480 kg/m³ and the adhesive used must be in the family of heat-resistant melamine-urea-formaldehyde. The outer lamella thicknesses must be equal to or greater than 30 mm.

Table 31 Back to back penetration seal with cables

Services	Maximum aperture	FRL
Electrical cables up to 21 mm Ø (single, bundled and on trays)	1200 mm × 600 mm	-/90/45
Electrical cables up to 50 mm Ø (single, bundled and on trays) E 90, EI 60		-/90/60
Electrical cables up to 80 mm Ø (single, bundled and on trays)		-/90/60
Cables up to Ø 21 mm in tied bundles up to Ø 100 mm		-/90/60
Steel cable trays & ladders		-/90/60
Non-sheathed wires up to Ø 24 mm		-/90/30
PE-X pipe-in-pipe up to 25 mm diameter / 1.0 mm wall		-/90/90 C/C

6.3.3.2 Cable penetration seal with 2 × Protecta FR Board 1-S

Penetration Seal:
 500 mm (min.)* LI (Local Interrupted) or CI (Continuous Interrupted) insulated metallic pipes fitted at any position within the aperture, with 2 layers of 50 mm Protecta FR Board 1-S within the floor with the coated sides downwards. The external board layer has a minimum 100 mm overlap all around the aperture.

Construction details

Note: Density must be minimum 480 kg/m³ and the adhesive used must be in the family of heat-resistant melamine-urea-formaldehyde. The outer lamella thicknesses must be equal to or greater than 30 mm.

Table 32 Back to back penetration seal with pipes

Services	Max. aperture	Insulation, minimum thickness and density	FRL
Mild or stainless steel pipe			
60 mm diameter*	1200 mm × 600 mm	20 mm glass or stone wool insulation 75 kg/m ³	-/90/60 C/U
273 mm diameter*		25 mm glass or stone wool insulation 75 kg/m ³	-/90/60 C/U
Copper or steel pipes			
15 mm diameter*	1200 mm × 600 mm	20 mm glass or stone wool insulation 75 kg/m ³	-/90/90 C/C
54 mm diameter*			-/90/90 C/C
Alupex pipes			
16 mm diameter*	1200 mm × 600 mm	20 mm glass or stone wool insulation 75 kg/m ³	-/90/60 C/C
75 mm diameter*			
*See below graphs for interpolation sizes			

Mild or Stainless Steel Pipes - E 90 C/U, EI 60 C/U

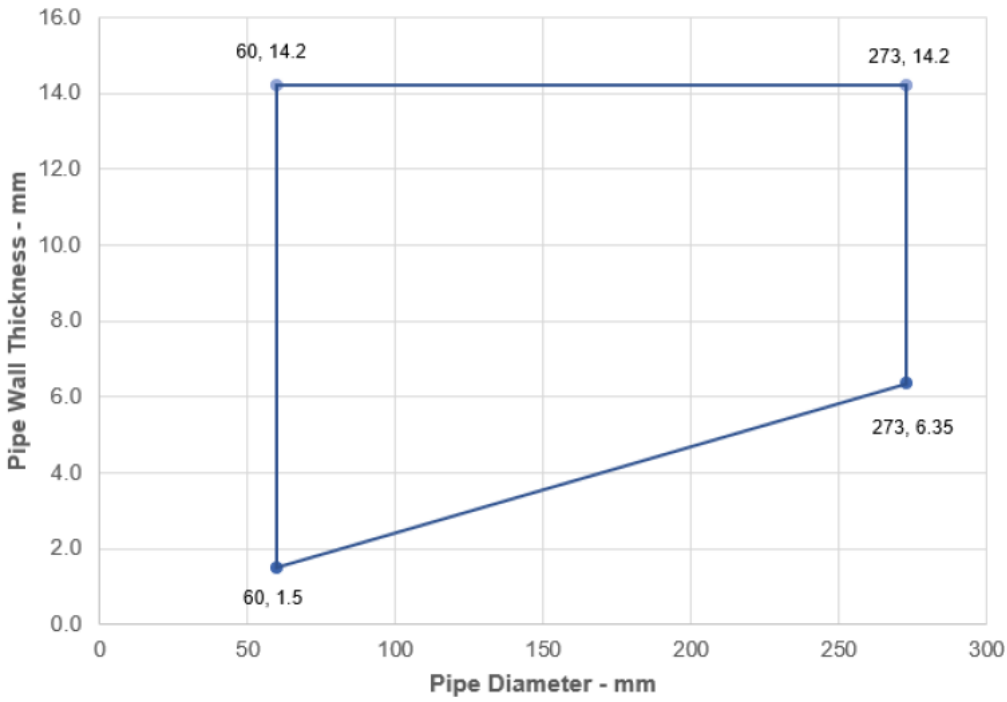

Figure 14 Intermediate pipe wall thicknesses for typical mild or stainless steel pipe diameters

Copper or Steel Pipes- EI 90 C/C

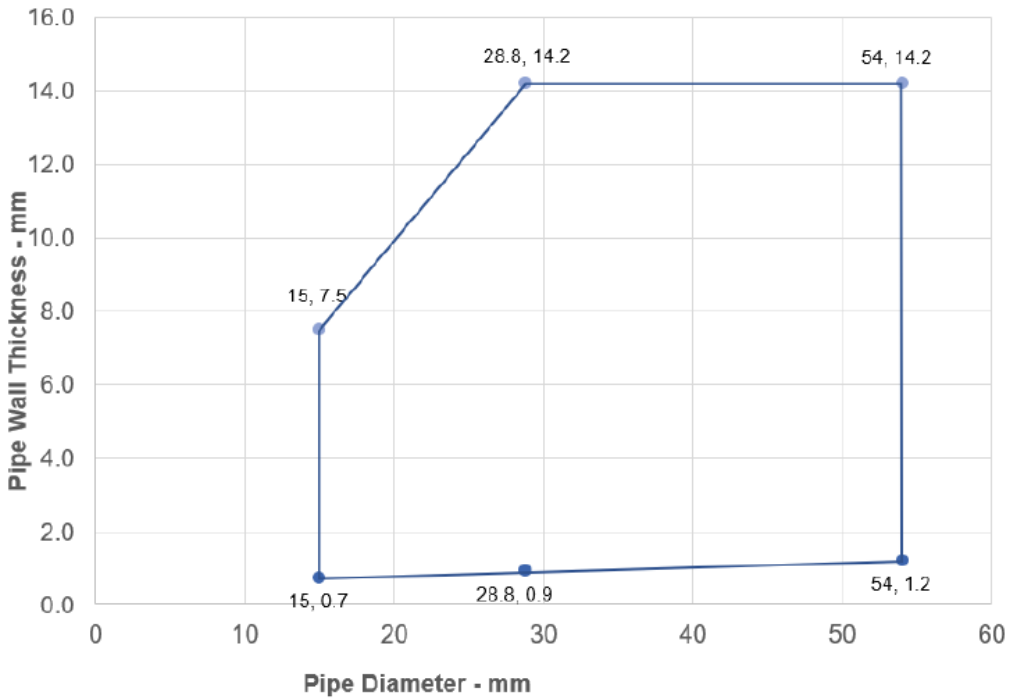

Figure 15 Intermediate pipe wall thicknesses for typical copper or steel pipe diameters

ALUPEX Pipes - E 90 C/C, EI 60 C/C

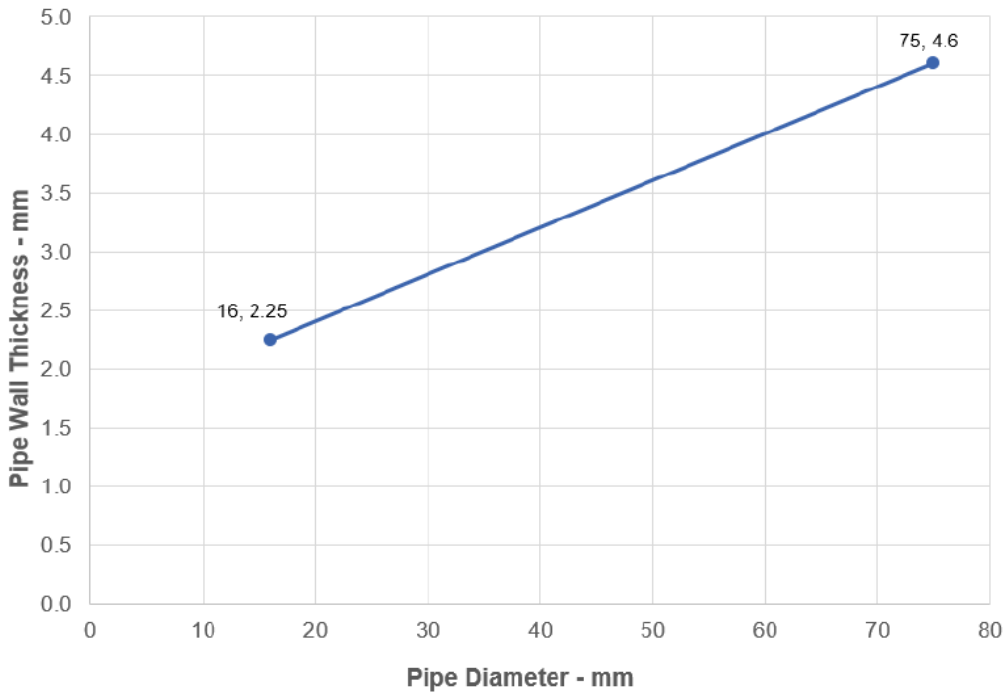

Figure 16 Intermediate pipe wall thicknesses for typical Alupex pipe diameters

6.3.4 Flexible or rigid wall constructions according to section 4.1 2 with wall thickness of minimum 75 mm

6.3.4.1 Cable penetration seal with 2 × Protecta FR Board 30 1-S

Penetration seal:
Cables fitted at any position within the aperture, with 30 mm Protecta FR Board 1-S to both sides of the wall. Minimum 30 mm separation between pipes

Construction details:

Table 33 Double side penetration seal with cables

Services	Maximum Aperture	FRL
Electrical cables up to Ø 21 mm (single, bundled on trays)	1200 mm wide × 600 mm high	-/30/30
Electrical cables up to Ø 80 mm (single, bundled and on trays)		-/30/30
Cables including telecoms up to Ø 21 mm in tied bundles up to Ø 100 mm		
Steel cable trays & ladders		
Unsheathed wires up to Ø 24 mm		-/30/-
Plastic conduits maximum 32 mm diameter		-/30/30

Table 34 Double side penetration seal with pipes

Services	Maximum aperture	Insulation, minimum thickness and density Continuous sustained (CS)	FRL
Mild or stainless steel pipe			
4 mm diameter/0.7-14.2 mm wall	1200 mm wide × 600 mm high	None	-/30/30 C/U
22 mm diameter/2.0-14.2 mm wall			-/30/30 C/U
40 mm diameter/1.0-14.2 mm wall*		20 mm Stone wool insulation 80 kg/m ³	-/30/30 C/U
40 mm diameter/1.0-14.2 mm wall*		30 mm Stone wool insulation 80 kg/m ³	-/30/30 C/U
50 mm diameter/1.7-14.2 mm wall*			
60 mm diameter/1.8-14.2 mm wall*			
75 mm diameter/2.1-14.2 mm wall*			
90 mm diameter/2.3-14.2 mm wall*			
100 mm diameter/2.5-14.2 mm wall*			
115 mm diameter/2.8-14.2 mm wall*			
140 mm diameter/3.2-14.2 mm wall*			
165 mm diameter/ 3.6-14.2 mm wall*			
180 mm diameter/ 3.9-14.2 mm wall*			
200 mm diameter/ 4.2-14.2 mm wall*			
219 mm diameter/ 4.5-14.2 mm wall*			
250 mm diameter/ 5.0-14.2 mm wall*			
300 mm diameter/ 5.9-14.2 mm wall*			
324 mm diameter/ 6.35-14.2 mm wall*			
*Typical pipe diameters shown, see below graph for intermediate sizes			

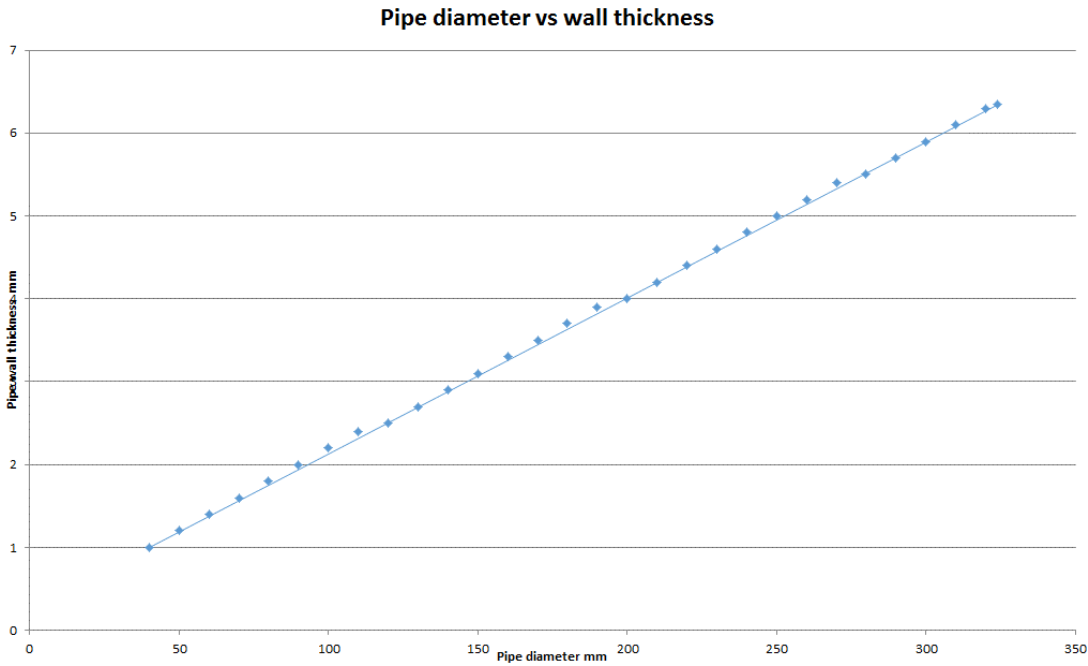

Figure 17 Intermediate pipe wall thicknesses for typical mild or stainless steel pipe diameters

6.3.4.2 Cable penetration seal with 2 × Protecta FR Board 1-S

Penetration seal:
 Cables fitted at any position within the aperture, with 50 mm Protecta FR Board 1-S to both sides of the wall.

Construction details:

NOTE: insulated metal pipes may also be included within the same seal as cables to be subject to minimum 100 mm separation.

Table 35 Double side penetration seal with cables

Services	Maximum aperture	FRL
None (blank)	As section 4.1 6)	-/60/60
Single electrical cables up to Ø 21 mm		-/60/60
Electrical cables up to Ø 80 mm (single, bundled and on trays)		-/60/30
Cables up to Ø 21 mm in tied bundles up to Ø 100 mm		-/60/60
Steel cable trays & ladders		
Steel conduit up to Ø 16 mm		-/60/60 C/U
copper conduit up to Ø 16 mm		-/60/30 C/U
Unsheathed wires up to Ø 24 mm		-/60/30
Plastic conduits up to Ø 16 mm		-/60/60 C/U, C/C

6.3.5 Flexible or rigid wall constructions according to section 4.1 2 with wall thickness of minimum 100 mm

6.3.5.1 Cable penetration seal with 2 × Protecta FR Board 1-S

Penetration seal:
Cables fitted at any position within the aperture, with 50 mm Protecta FR Board 1-S to both sides of the wall.

Construction details:

Table 36 Double side penetration seal with cables

Services	Maximum aperture	FRL
None (blank)	As section 4.1 6)	-/120/120
Electrical Cables up to Ø 21 mm		-/120/60
Electrical Cables up to Ø 80 mm (single, bundled and on trays)		-/60/60
Cables up to Ø 21 mm in tied bundles up to Ø 100 mm		
Steel Cable trays & Ladders		-/60/60 C/U
Steel conduit up to Ø 16 mm		
Copper conduit up to Ø 16 mm		-/60/45 C/U
Unsheathed wires up to Ø 24 mm		-/60/30
Plastic conduits up to Ø 16 mm		-/60/60 C/C

6.3.5.2 Pipe penetration seal with 2 × Protecta FR Board 1-S

Penetration seal:
 CS (Continuous Sustained) insulated metallic pipes fitted at any position within the aperture, with 50 mm Protecta FR Board 1-S to both sides of the wall. Minimum separation between penetration seals and seal edges of 30 mm.

Construction details:

Note: Cavity Wall Insulation is Optional

<p>Penetration seal: CS (Continuous Sustained) insulated metallic pipes fitted at any position within the aperture, with 50 mm Protecta FR Board 1-S to both sides of the wall. Minimum separation between penetration seals and seal edges of 30 mm.</p>	
Configuration 1	Configuration 2
<p>Key 1 Supporting Construction a₁ pipe/ top edge of seal separation a₂ Pipe/ side edge of seal separation a₃ Pipe/ pipe separation</p>	

Table 37 Double side penetration seal with pipes

Service	Insulation	FRL
Mild or stainless steel pipe		
40 mm diameter/ 1-14.2 mm wall	20 mm thick stone, mineral wool 80 kg/m ³	-120/120 C/U
40 mm diameter/1-14.2 mm wall*	30-80 mm thick stone, mineral wool min. 80 kg/m ³	
50 mm diameter/1.2-14.2 mm wall*		
60 mm diameter/1.4-14.2 mm wall*		
75 mm diameter/1.6-14.2 mm wall*		
90 mm diameter/1.9-14.2 mm wall*		
100 mm diameter/2.1-14.2 mm wall*		
115 mm diameter/2.4-14.2 mm wall*		
140 mm diameter/2.9-14.2 mm wall*		
165 mm diameter/ 3.4-14.2 mm wall*		
180 mm diameter/ 3.6-14.2 mm wall*		
200 mm diameter/ 4.0-14.2 mm wall*		
219 mm diameter/ 4.3-14.2 mm wall*		
250 mm diameter/ 5.0-14.2 mm wall*		
300 mm diameter/ 5.9-14.2 mm wall*		
324 mm diameter/ 6.35-14.2 mm wall*		

Service	Insulation	FRL
PE-X pipe in pipe system		
15 mm diameter × 2.5 mm wall inner /25 mm diameter outer	None	-/90/90 C/C

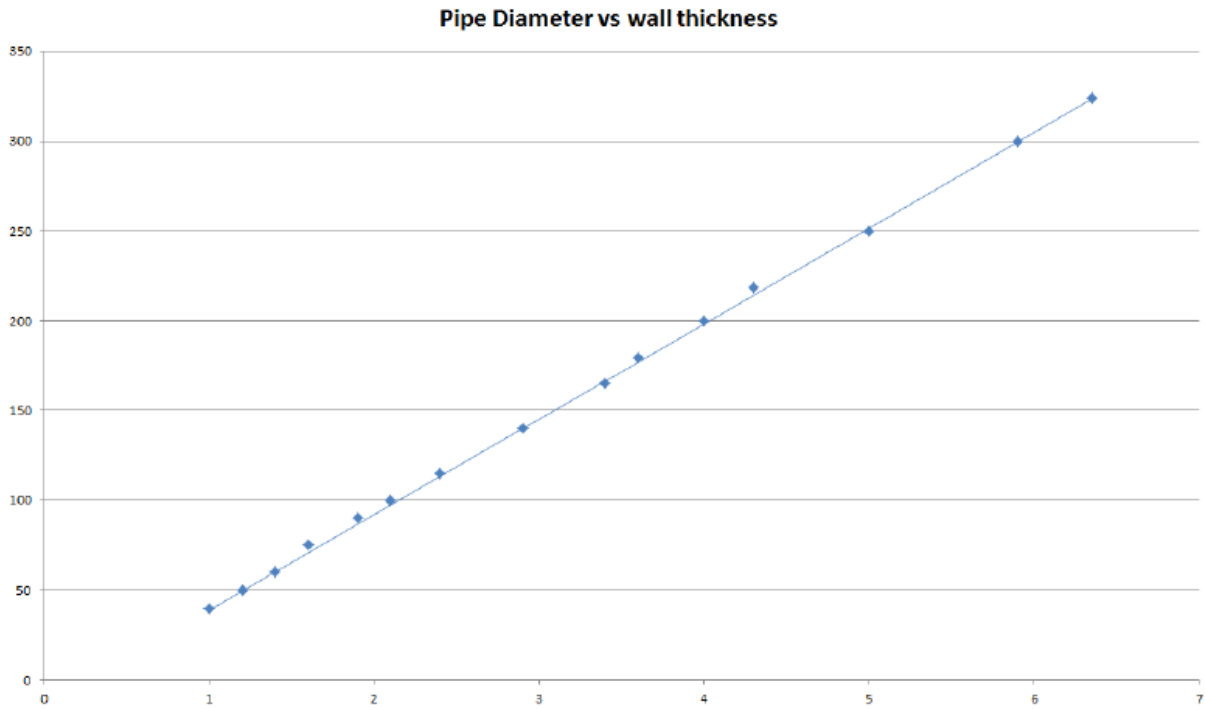

Figure 18 Intermediate pipe wall thicknesses for typical mild or stainless steel pipe diameters

Table 38 Double side penetration seal with pipes

Service	Insulation	FRL
Mild or stainless steel pipe		
4 mm diameter*	None	-/120/120 C/U
5-22 mm diameter*		-/120/60 C/U
Copper, mild or stainless steel pipe		
Up to 6 mm diameter/0.7-14.2 mm wall	None	-/120/60 C/C
Up to 15 mm diameter/0.7-7.5 mm wall	20 mm thick glass or stone wool min. 75 kg/m ³	-/60/60 C/C
16-54 mm diameter/0.7-14.2 mm wall*		-/60/45 C/C
Up to 54 mm diameter/0.7-14.2 mm wall*	40 mm thick glass or stone wool min. 75 kg/m ³	-/60/60 C/C
Alupex pipe		
20 mm diameter/2.0 mm wall	None	-/120/120 C/C
16 mm diameter/2.0-2.25 mm wall	20 mm thick glass or stone wool min. 75 kg/m ³	-/120/90 C/C
16-75 mm diameter*	25-60 mm thick glass or stone wool min. 75 kg/m ³	-/120/90 C/C
PVC-U pipe		
6 mm diameter*	None	-/120/120 U/C
7-32 mm diameter*		-/60/60 U/C
32 mm diameter*		-/90/90 U/C
PE pipe		
20 mm diameter/2.0 mm wall	None	-/120/90 U/C
21-32 mm diameter/2.0-3.0 mm wall		-/60/60 U/C
32 mm diameter/3.0 mm wall		-/90/90 U/C
PP pipe		
20 mm diameter/2.2 mm wall	None	-/120/60 U/C
Up to 32 mm diameter/1.8 mm wall		
*See below graphs for interpolation pipe sizes		

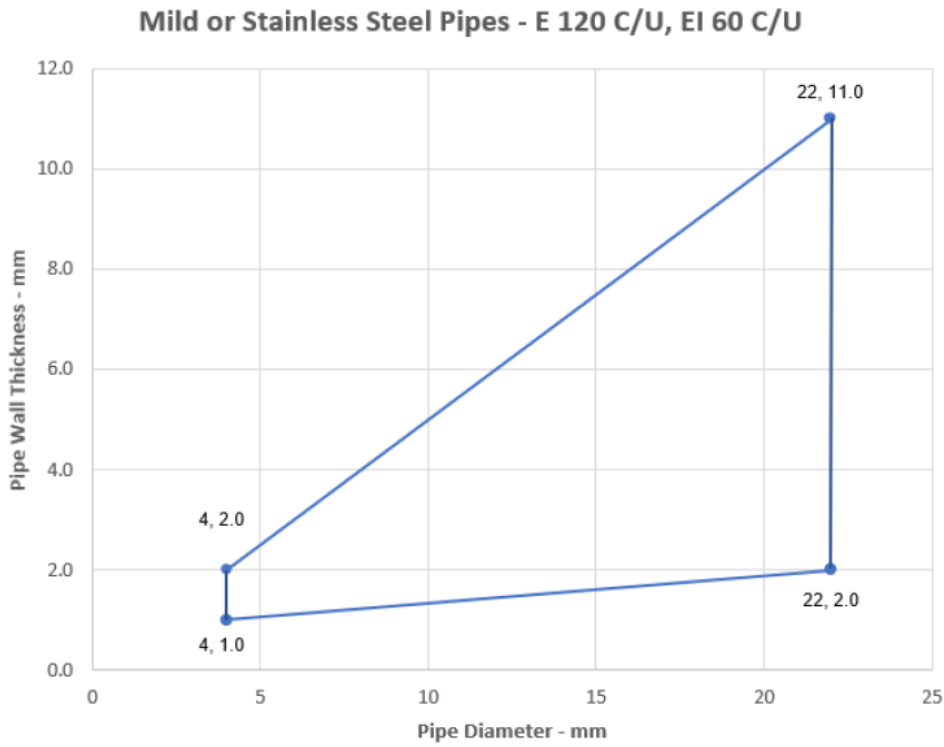

Figure 19 Intermediate pipe wall thicknesses for mild or stainless steel pipe diameters

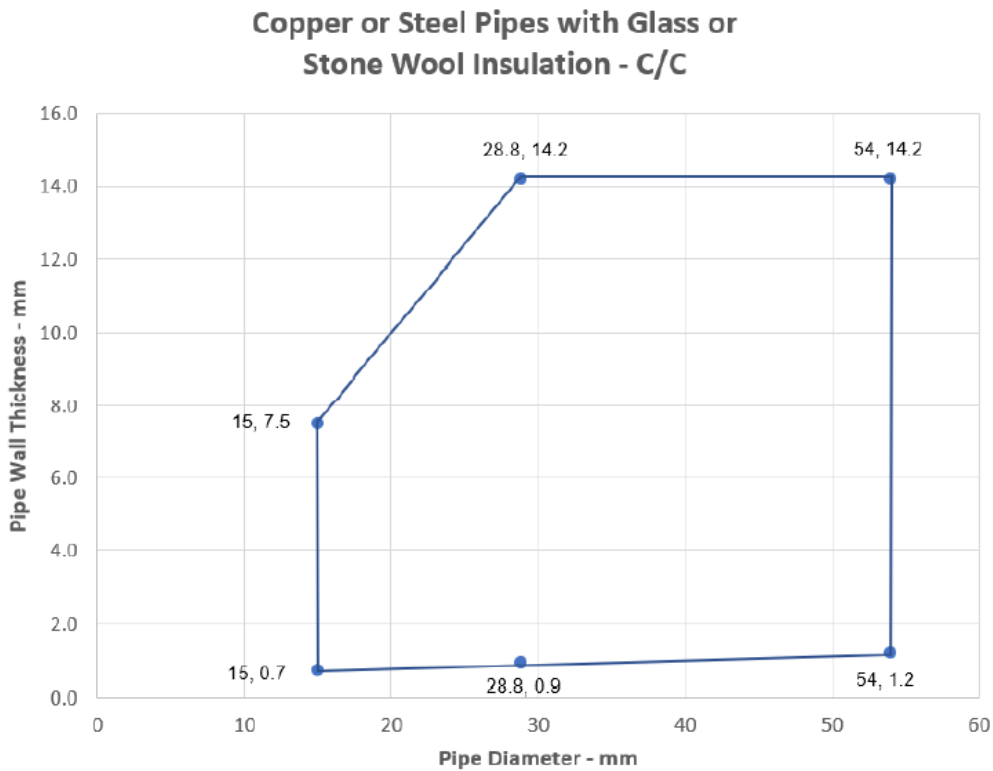

Figure 20 Intermediate pipe wall thicknesses for copper or steel pipe diameters with Glass or Stone wool insulation. Applicable to C/C end conditions.

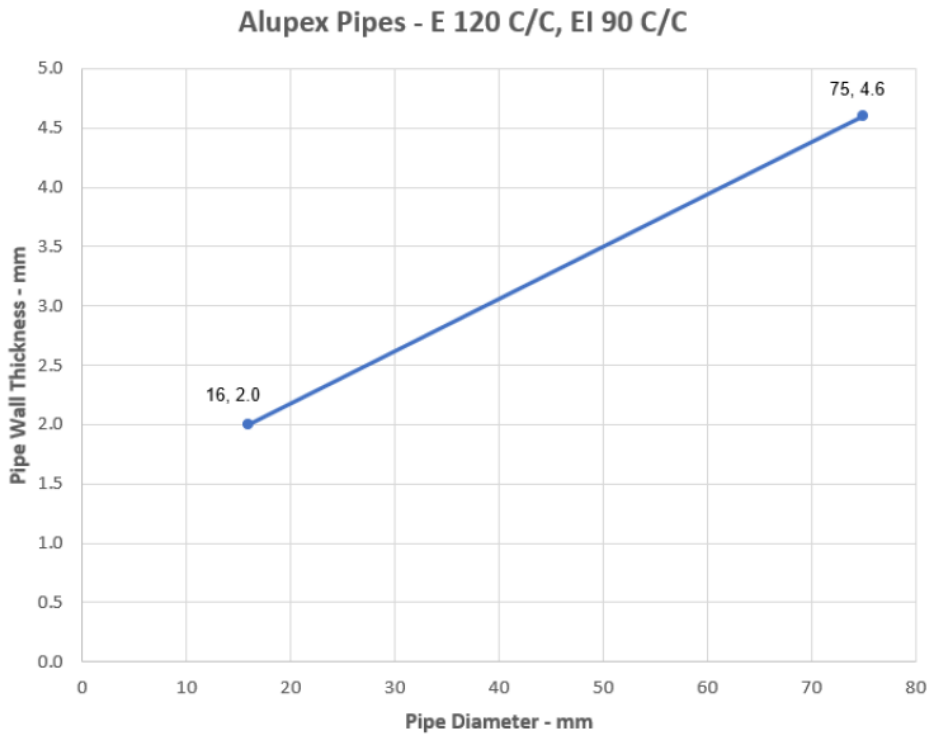

Figure 21 Intermediate pipe wall thicknesses for Alupex pipe diameters

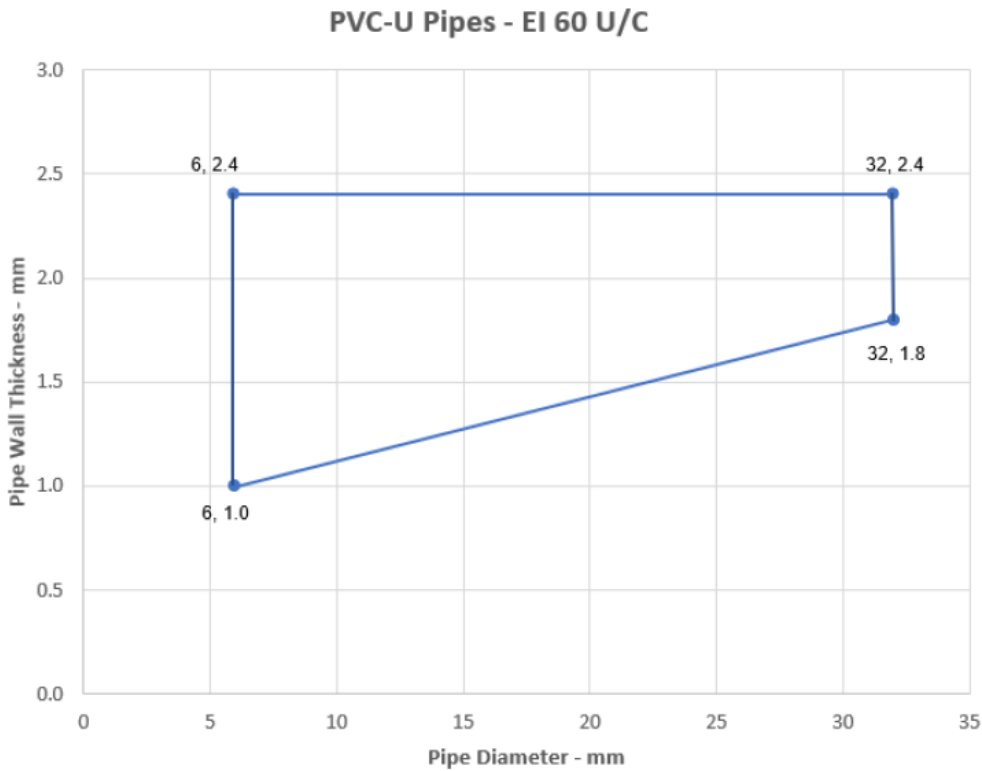

Figure 22 Intermediate pipe wall thicknesses for PVC-U pipe diameters

6.3.5.3 Pipe penetration seal with 2 × Protecta FR Board 1-S

Penetration seal:

CS (Continuous Sustained) insulated metallic pipes fitted at any position within the aperture, with 50 mm Protecta FR Board 1-S to both sides of the wall. Minimum separation between penetration seals and seal edges of 30 mm. Protecta FR Pipe Wraps are required to be fitted around the pipe insulation.

Construction details:

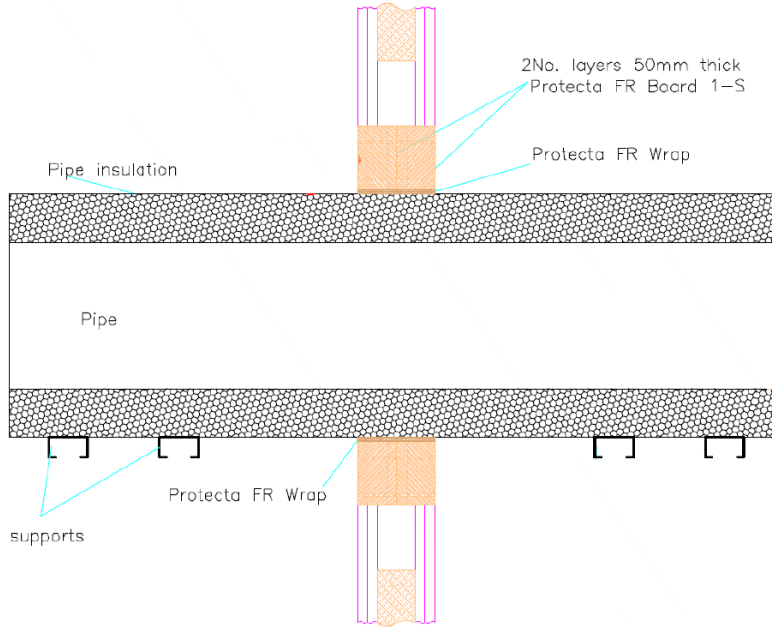

Note: Cavity Wall Insulation is Optional.

Configuration 1

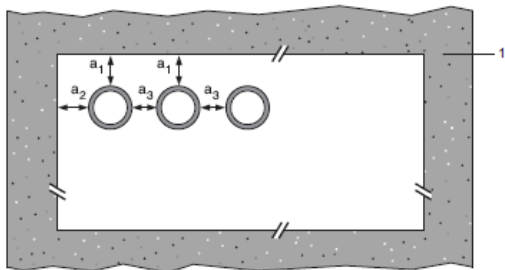

Configuration 2

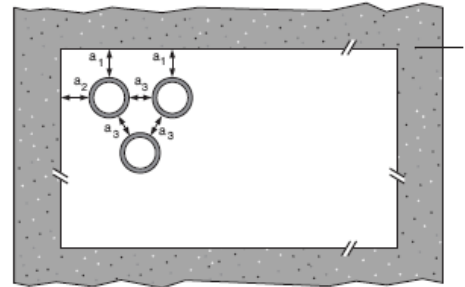

Key:

- 1 Supporting construction
- a₁ Pipe/top edge of seal separation
- a₂ Pipe/side edge of seal separation
- a₃ Pipe/pipe separation

Table 39 Double side penetration seal with pipes

Services	Insulation	Protecta FR Wrap	FRL
Mild or stainless steel pipe			
40 mm diameter/1-14.2 mm wall	32-50 mm thick Elastomeric insulation minimum class B-s3, d0 or PE Foam insulation	3 layers 50 mm × 1.8mm	-/90/90 C/U
40 mm diameter/1-14.2 mm wall*			
50 mm diameter/1.2-14.2 mm wall*			

Services	Insulation	Protecta FR Wrap	FRL
60 mm diameter/1.4-14.2 mm wall*			
75 mm diameter/1.6-14.2 mm wall*			
90 mm diameter/1.9-14.2 mm wall*			
100 mm diameter/2.1-14.2 mm wall*			
115 mm diameter/2.4-14.2 mm wall*			
140 mm diameter/2.9-14.2 mm wall*			
165 mm diameter/ 3.4-14.2 mm wall*			
180 mm diameter/ 3.6-14.2 mm wall*			
200 mm diameter/ 4.0-14.2 mm wall*			
219 mm diameter/ 4.3-14.2 mm wall*			
250 mm diameter/ 5.0-14.2 mm wall*			
300 mm diameter/ 5.9-14.2 mm wall*			
324 mm diameter/ 6.35-14.2 mm wall*			

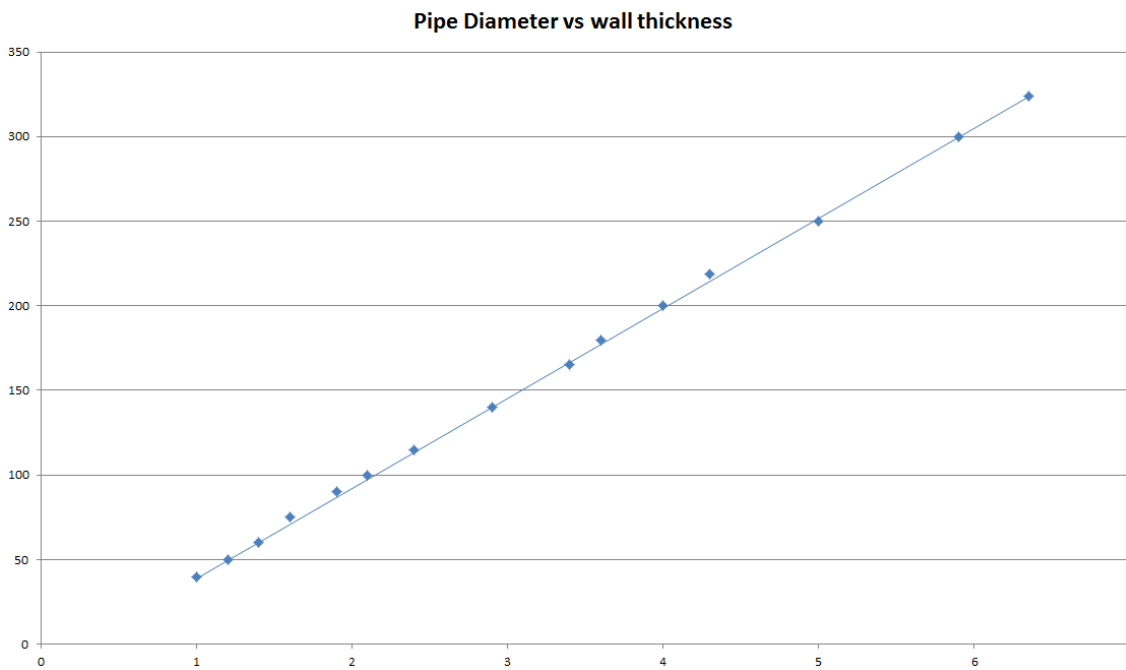

Figure 23 Intermediate pipe wall thicknesses for mild or stainless steel pipe diameters

6.3.5.4 Pipe penetration seal with 2 × Protecta FR Board 1-S

Penetration Seal:
 CS (Continuous Sustained) insulated metallic pipes fitted at any position within the aperture, with 50 mm Protecta FR Board 1-S to both sides of the wall. Protecta FR Pipe Wraps are required to be fitted around the pipe insulation.

Construction details:

Table 40 Two layer penetration seal with pipes

Services	Wrap	Insulation	FRL
Mild or stainless steel pipe			
Up to 40 mm diameter/1-14.2 mm wall	50 mm × 1.8 mm Protecta FR Pipe Wrap fitted centrally	13 mm elastomeric insulation minimum class B-s3, d0 or PE Foam insulation	-/120/120 U/C, U/U, C/U, C/C
Up to 40 mm diameter/1-14.2 mm wall*	2 off 50 mm × 3.6 mm Protecta FR Pipe Wrap, one fitted flush to each face of seal	13 – 32 mm elastomeric insulation minimum class B-s3, d0 or PE Foam insulation	-/120/60 U/C, U/U, C/U, C/C
50 mm diameter/1.3-14.2 mm wall*			
60 mm diameter/1.6-14.2 mm wall*			
75 mm diameter/2-14.2 mm wall*			
90 mm diameter/2.4-14.2 mm wall*			
100 mm diameter/2.7-14.2 mm wall*			
115 mm diameter/3.1-14.2 mm wall*			
140 mm diameter/3.8-14.2 mm wall*			
165 mm diameter/ 4.5-14.2 mm wall*			
*Typical pipe diameters shown, see below graph for intermediate sizes			

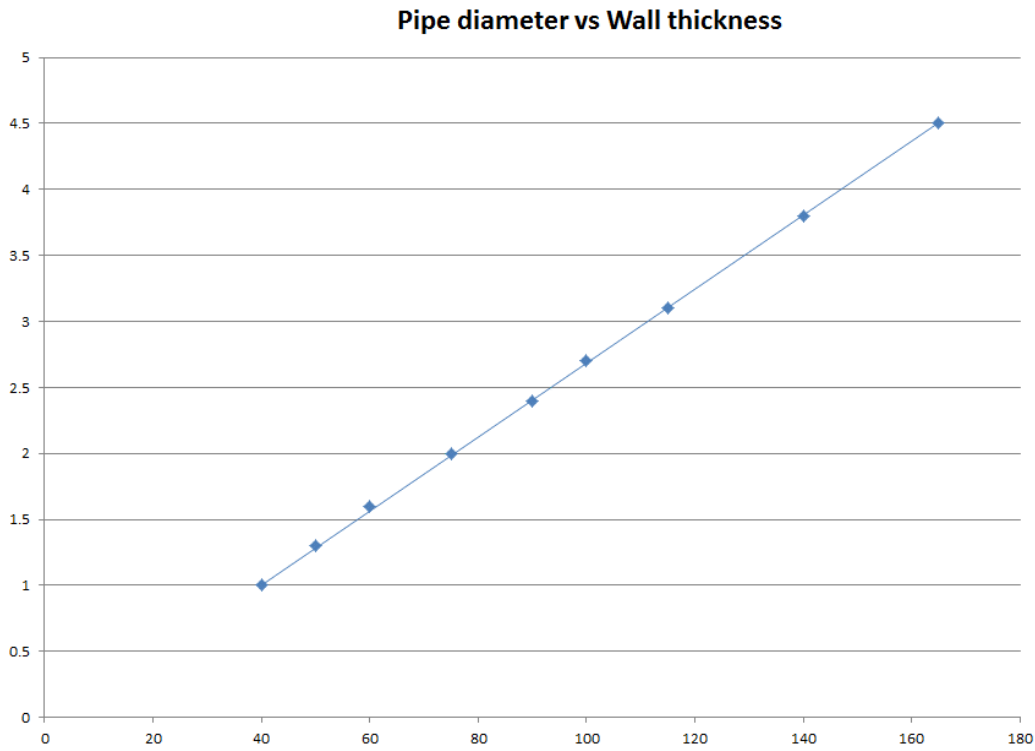

Figure 24 Intermediate pipe wall thicknesses for mild or stainless steel pipe diameters

6.3.5.5 Pipe penetration seal with 2 × Protecta FR Board 1-S

Penetration seal:

500 mm (min.) LI (Local Interrupted) or CI (Continuous Interrupted) insulated or uninsulated metallic and composite pipes fitted at any position within the aperture, with 50 mm Protecta FR Board 1-S to both sides of the wall.

Construction details:

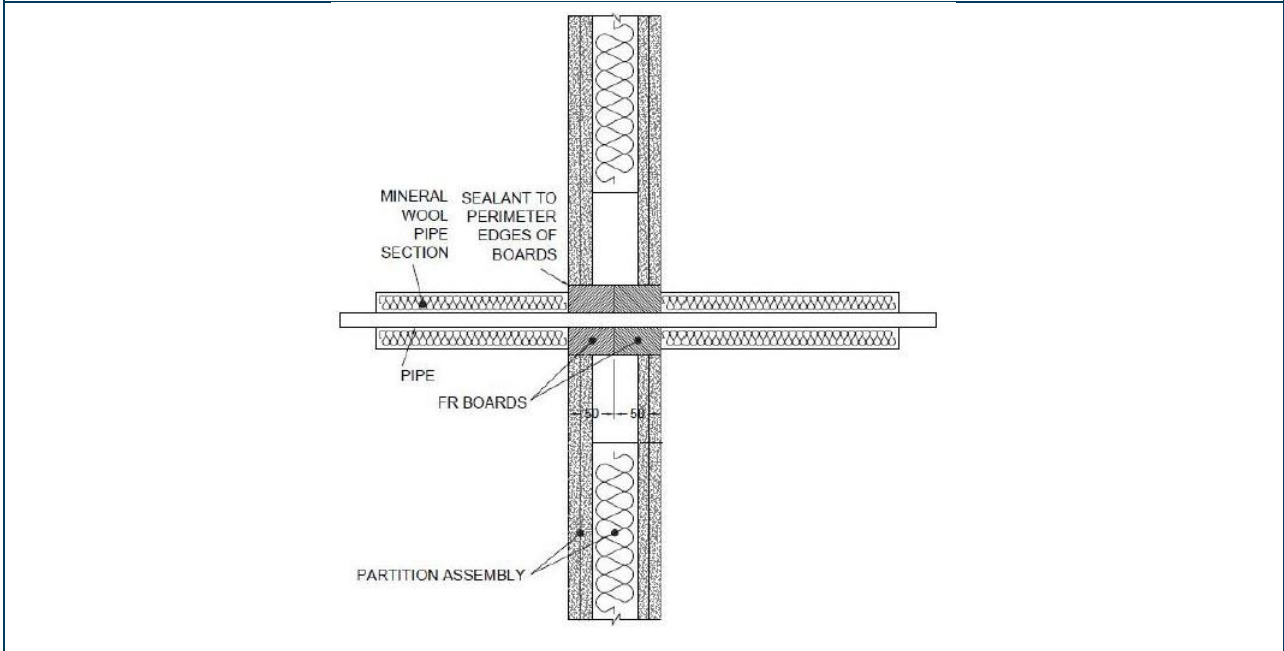

Table 41 Two layer penetration seal with pipes

Services	Insulation	FRL
Copper pipe up to 54 mm diameter/1-14.2 mm wall	20 mm stone wool 80 kg/m ³	-/120/120 C/C
Mild or stainless steel pipe 114 mm diameter/11 mm wall	None	-/90/- C/U
Mild or stainless steel pipe		
40 mm diameter/1-14.2 mm wall	20 mm stone wool 80 kg/m ³	-/120/120 C/U
40 mm diameter/1-14.2 mm wall*	30 mm stone wool 80 kg/m ³	-/120/90 C/U
50 mm diameter/1.2-14.2 mm wall*		
60 mm diameter/1.4-14.2 mm wall*		
75 mm diameter/1.7-14.2 mm wall*		
90 mm diameter/2-14.2 mm wall*		
100 mm diameter/2.2-14.2 mm wall*		
115 mm diameter/2.5-14.2 mm wall*		
140 mm diameter/3-14.2 mm wall*		
165 mm diameter/3.5-14.2 mm wall*		
180 mm diameter/3.8-14.2 mm wall*		
200 mm diameter/4.2-14.2 mm wall*		
219 mm diameter/4.5-14.2 mm wall*		
*Typical pipe diameters shown, see below graph for intermediate sizes		

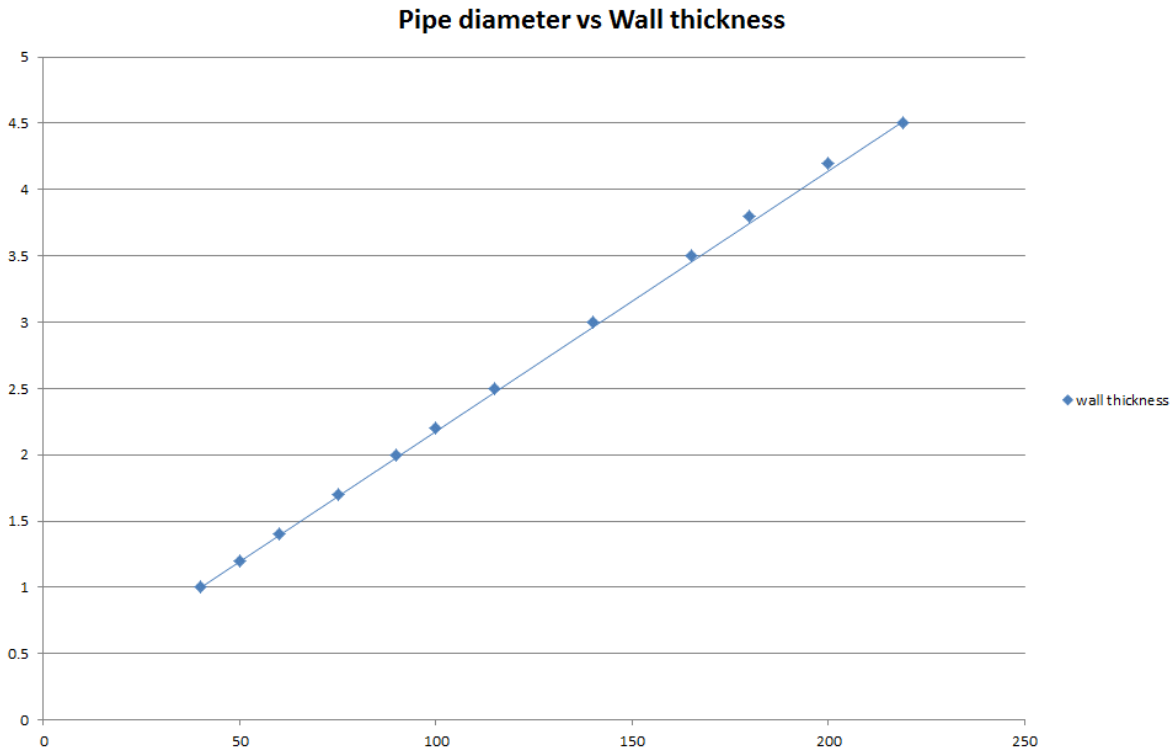

Figure 25 Intermediate pipe wall thicknesses for mild or stainless steel pipe diameters

Table 42 Two layer penetration seal with pipes

Services	Insulation (minimum)	FRL
Alupex pipe		
16 mm diameter/2.25 mm wall	20 mm stone wool 80 kg/m ³	-/120/120 C/C
20 mm diameter/2.5 mm wall		-/60/60 C/C
26 mm diameter/3 mm wall		
32 mm diameter/3 mm wall		
40 mm diameter/3.5 mm wall		
50 mm diameter/4 mm wall		
63 mm diameter/4.5 mm wall		
75 mm diameter/4.7 mm wall		

6.3.5.6 Pipe penetration seal with 2 × Protecta FR Board 1-S

Penetration seal:
 LS (Local Sustained) or CS (Continuous Sustained) insulated metallic and composite pipes fitted at any position within the aperture, with 50 mm Protecta FR Board 1-S to both sides of the wall. Protecta FR Pipe Wraps are required to be fitted around the pipe to both sides of the seal.

Construction details:

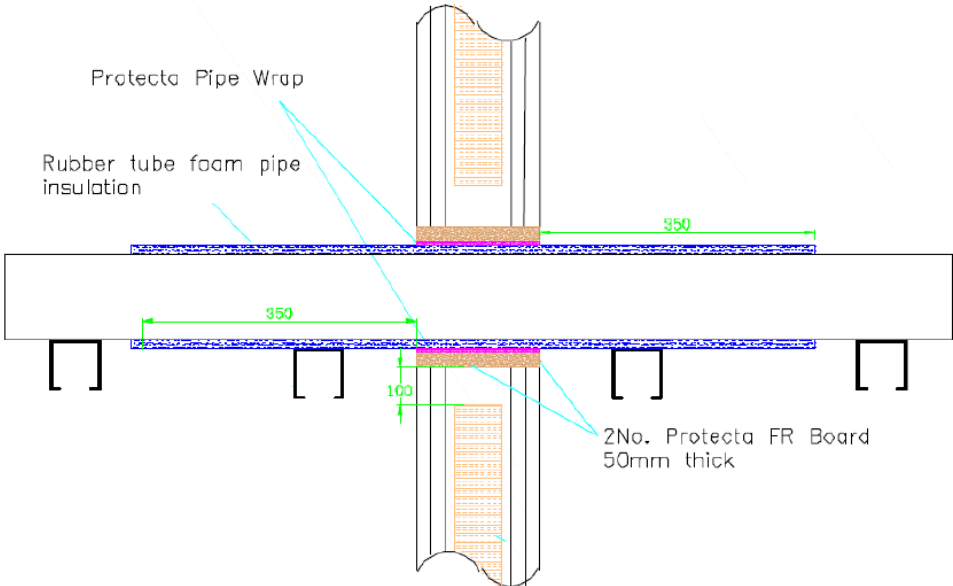

Note: Cavity Wall Insulation is Optional.

Table 43 Two layer penetration seal with pipes

Services	Wrap	Insulation	FRL
Mild or stainless steel pipe			
16 mm diameter/1.0 mm wall	50 mm × 1.8 mm Protecta FR Pipe Wrap fitted to both sides of the seal	15 mm phenolic foam insulation (CS)	-/90/90 C/U
16-273 mm diameter/1.0-14.2 mm wall*		25-100 mm phenolic foam insulation (CS)	
Copper pipe			
12 mm diameter/1 mm wall	50 mm × 3.6 mm Protecta FR Pipe Wrap fitted to both sides of the seal	9 mm elastomeric insulation minimum class B-s3, d0 or PE Foam insulation (LS and CS)	-/120/120 C/C
12-54 mm diameter/1-1.2 mm wall		9-13 mm elastomeric insulation minimum class B-s3, d0 or PE Foam insulation (LS and CS)	-/120/90 C/C
12-54 mm diameter/1-1.2 mm wall		13-25 mm elastomeric insulation minimum class B-s3, d0 or PE Foam insulation (LS and CS)	-/120/60 C/C

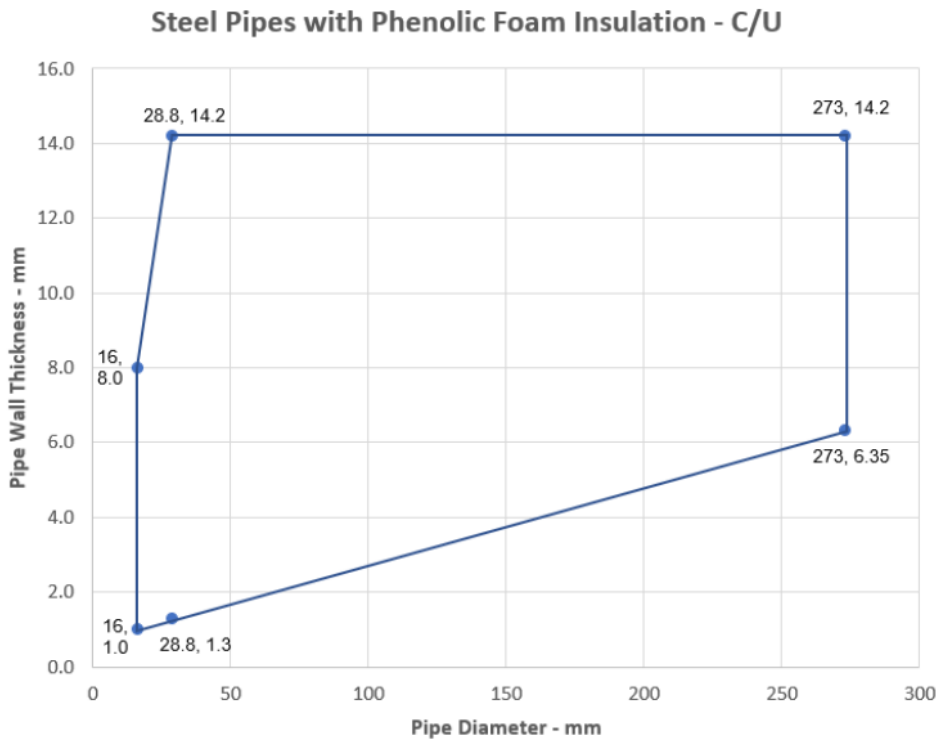

Figure 26 Intermediate pipe wall thicknesses for steel pipe diameters with Phenolic foam insulation – C/U

Table 44 Two layer penetration seal with pipes

Services	Wrap	Insulation	FRL
Alupex pipe			
16 mm diameter/2.25 mm wall	50 mm × 3.6 mm Protecta FR Pipe Wrap fitted to both sides of the seal	9-25 mm elastomeric insulation minimum class B-s3, d0 or PE Foam insulation	-/60/60 C/C
20 mm diameter/2.5 mm wall			
26 mm diameter/3 mm wall			
32 mm diameter/3 mm wall			
40 mm diameter/3.5 mm wall			
50 mm diameter/4 mm wall			
63 mm diameter/4.5 mm wall			
75 mm diameter/4.7 mm wall			
25 mm diameter/2.5 mm wall		13 mm polyethylene foam with plastic sheaving	-/90/60 C/C

Table 45 Two layer penetration seal with pipes

Services	Outer diameter including insulation	Pipe wrap	Pipe insulation	FRL
PE pipe				
Maximum 160 mm diameter pipe*	Maximum 68 mm diameter	50 mm × 3.6 mm Protecta FR Pipe Wrap fitted to both sides of the seal	9-50 mm Elastomeric insulation minimum class B-s3, d0 or PE Foam insulation	-/60/60 C/C

Services	Outer diameter including insulation	Pipe wrap	Pipe insulation	FRL
	Maximum 178 mm diameter	50 mm × 10.8 mm Protecta FR Pipe Wrap fitted to both sides of the seal		
	Maximum 260 mm diameter	50 mm × 18.0 mm Protecta FR Pipe Wrap fitted to both sides of the seal		
PP pipe				
Maximum 160 mm diameter pipe*	Maximum 68 mm diameter	50 mm × 3.6 mm Protecta FR Pipe Wrap fitted to both sides of the seal	9-50 mm Elastomeric insulation minimum class B-s3, d0 or PE Foam insulation	-/60/60 C/C
	Maximum 178 mm diameter	50 mm × 10.8 mm Protecta FR Pipe Wrap fitted to both sides of the seal		
	Maximum 260 mm diameter	50 mm × 18.0 mm Protecta FR Pipe Wrap fitted to both sides of the seal		
*See below graph for interpolation pipe sizes				

PE Pipes - EI 60 C/C

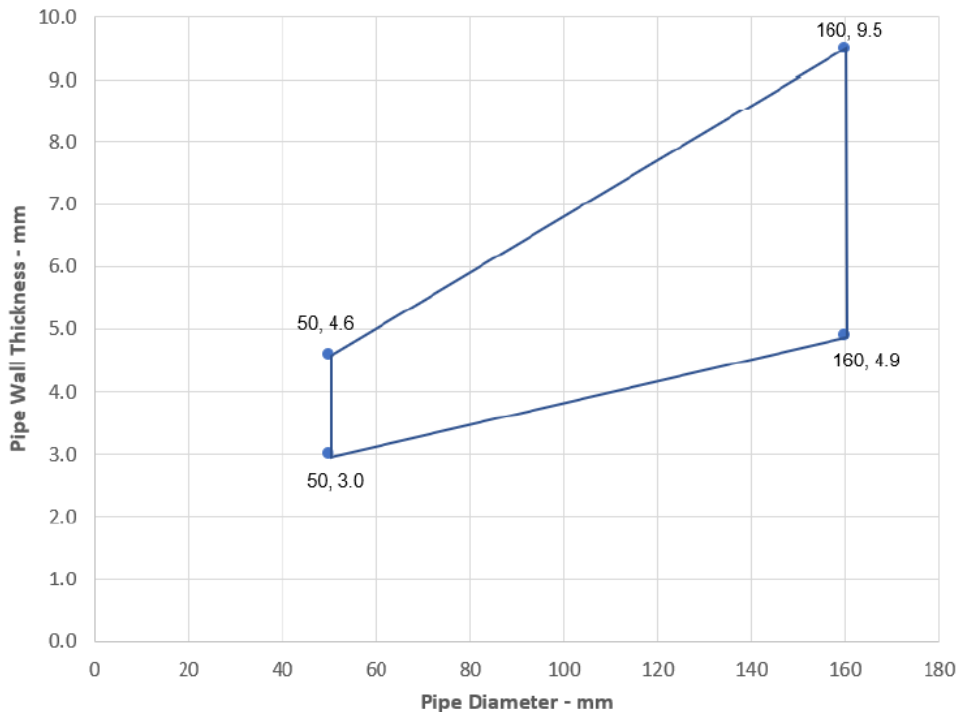

Figure 27 Intermediate pipe wall thicknesses for PE pipe diameters

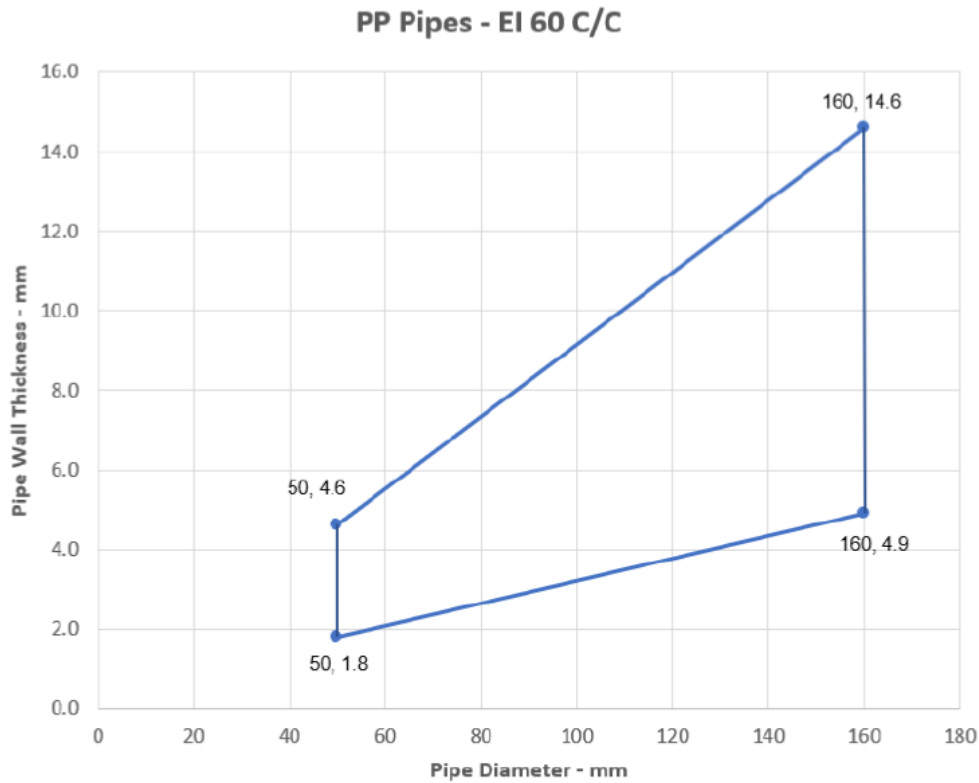

Figure 28 Intermediate pipe wall thicknesses for PP pipe diameters

6.3.5.7 *Protecta FR Pipe Wrap penetration seal for plastic pipes, in 2 × Protecta FR Board 1-S, in flexible or rigid walls*

Penetration seal:
 Combustible pipes sealed with Protecta FR Pipe Wrap, to both sides of the wall. Minimum separation between penetration seals and seal edges of 30 mm. (Configuration 1 and 2).

Construction details:

Penetration seal:

Combustible pipes sealed with Protecta FR Pipe Wrap, to both sides of the wall. Minimum separation between penetration seals and seal edges of 30 mm. (Configuration 1 and 2).

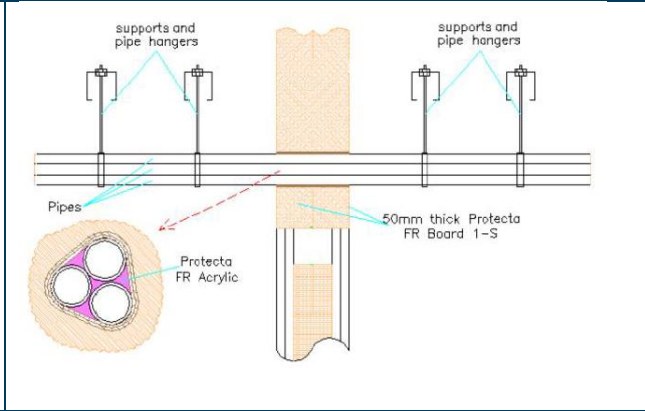
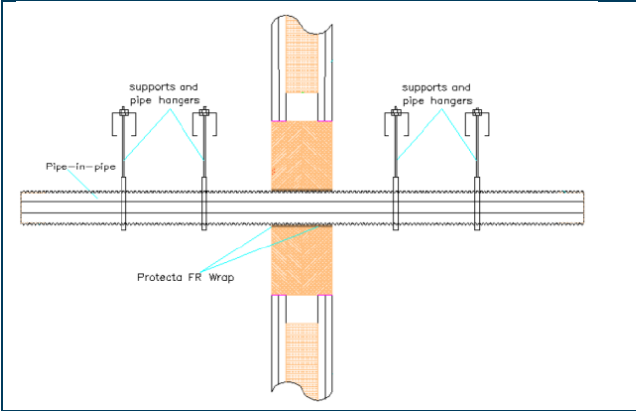

Configuration 1

Configuration 2

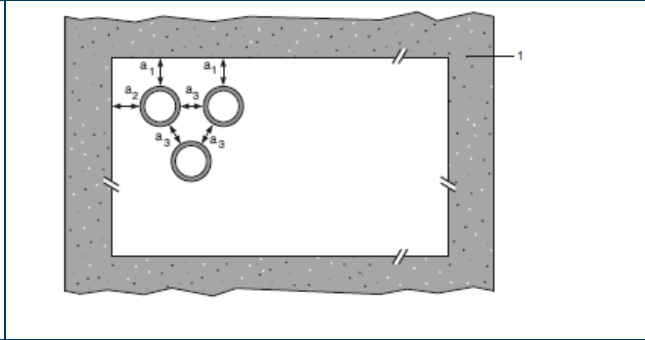
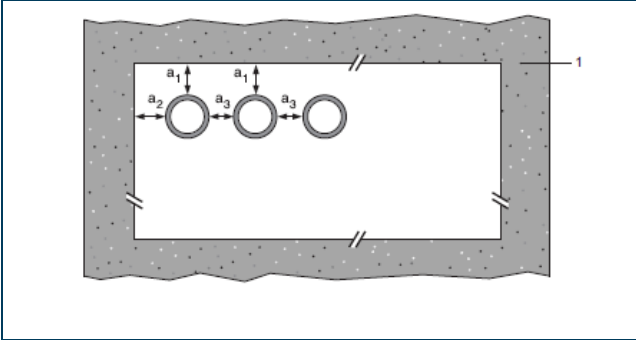

Key:

- 1 Supporting construction
- a₁ Pipe/top edge of seal separation
- a₂ Pipe/side edge of seal separation
- a₃ Pipe/pipe separation

Table 46 Protecta FR Pipe Wrap penetration seal for plastic pipes

Services	Wraps (both sides)	Permitted configuration for seal separation	FRL
PVC-U pipe			
Diameter up to 40 mm, wall thickness 1.9 – 3.0 mm	50 mm × 1.8 mm (1 layer)	1 & 2	-/120/120 U/U, C/U, U/C, C/C
Diameter up to 110 mm, wall thickness 2.7 - 6.6 mm	50 mm × 3.6 mm (2 × 1.8 mm layer)		-/120/90 U/C, C/C
Diameter up to 125 mm, wall thickness 3.7 – 7.4 mm	50 mm × 5.4 mm (3 × 1.8 mm layer)		
Diameter up to 160 mm, wall thickness 9.5 mm *	50 mm × 7.2 mm (4 × 1.8 mm layer)		
Diameter up to 160 mm, wall thickness 4.0-9.5 mm*	50 mm × 10.8 mm (6 × 1.8 mm layer)		-/90/60 U/C, C/C
Diameter up to 200 mm, wall thickness 4.9-11.9 mm	50 mm × 10.8 mm (6 × 1.8 mm layer)		-/90/90 C/C
Diameter up to 315 mm, wall thickness 7.7-12.1 mm*	50 mm × 18 mm (10 × 1.8 mm layer)		-/90/90 C/C
Diameter up to 400 mm, wall thickness 9.8-15.3 mm*	50 mm × 28.8 mm (16 × 1.8 mm layer)		-/90/90 C/C
Diameter up to 110 mm, wall thickness 2.7–6.6 mm, fully or partially filled conduits with cables up to 14 mm diameter	50 mm × 3.6 mm (2 × 1.8 mm layer)		-/120/90 U/C
Diameter up to Ø 32 mm, wall thickness 1.5-2.4 mm with or without cables up to Ø 14 mm, in pipe bundles up to Ø 110 mm ¹⁾	50 mm × 3.6 mm (2 × 1.8 mm layer)	-/90/90 U/C	
PE pipe			
Diameter up to 40 mm, wall thickness 2.4 – 3.7 mm	50 mm × 1.8 mm (1 layer)	1 & 2	-/120/120 U/U, C/U, U/C, C/C
Diameter up to 110 mm, wall thickness 4.2 - 10 mm	50 mm × 3.6 mm (2 × 1.8 mm layer)		-/120/90 U/C, C/C
Diameter up to 125 mm, wall thickness 4.8 - 12 mm	50 mm × 5.4 mm (3 × 1.8 mm layer)		
Diameter up to 160 mm, wall thickness 14.6 mm	50 mm × 7.2 mm (4 × 1.8 mm layer)		
Diameter up to 160 mm, wall thickness 4.9 – 14.6	50 mm × 10.8 mm (6 × 1.8 mm layer)		-/90/60 U/C, C/C
Diameter up to 200 mm, wall thickness 6.2 – 18.2 mm	50 mm × 10.8 mm (6 × 1.8 mm layer)		-/90/90 C/C

Services	Wraps (both sides)	Permitted configuration for seal separation	FRL
Diameter up to 315 mm, wall thickness 18.7 mm	50 mm × 18 mm (10 × 1.8 mm layer)		-/90/90 C/C
Diameter up to 400 mm, wall thickness 23.7 mm	50 mm × 28.8 mm (16 × 1.8 mm layer)		-/90/90 C/C
Diameter up to 110 mm, wall thickness 4.2 - 10 mm, fully or partially filled conduits with cables up to 14 mm diameter	50 mm × 3.6 mm (2 × 1.8 mm layer)		-/120/90 U/C
Diameter up to Ø 40 mm, wall thickness 2.0 – 3.7 mm with or without cables up to Ø 14 mm, in pipe bundles up to Ø 110 mm ¹⁾	50 mm × 3.6 mm (2 × 1.8 mm layer)		-/90/90 U/C
PP pipe			
Diameter up to 40 mm, wall thickness 1.8 – 5.5 mm	50 mm × 1.8 mm (1 layer)	1 & 2	-/120/120 U/U, C/U, U/C, C/C
Diameter up to 110 mm, wall thickness 2.7 – 15.1 mm	50 mm × 3.6 mm (2 × 1.8 mm layer)		-/90/90 U/U, C/U, U/C, C/C
Diameter up to 125 mm, wall thickness 3.1 – 17.1 mm	50 mm × 5.4 mm (3 × 1.8 mm layer)		-/120/90 U/C, C/C
Diameter up to 160 mm, wall thickness 21.9 mm *	50 mm × 7.2 mm (4 × 1.8 mm layer)		-/60/60 U/C, C/C
Diameter up to 160 mm, wall thickness 4.9 – 21.9 mm*	50 mm × 10.8 mm (6 × 1.8 mm layer)		-/90/90 C/C
Diameter up to 200 mm, wall thickness 4.9 – 18.2 mm	50 mm × 10.8 mm (6 × 1.8 mm layer)		-/60/60 C/C
Diameter up to 315 mm, wall thickness 28.6 mm*	50 mm × 18 mm (10 × 1.8 mm layer)		-/120/90 U/C
Diameter up to 110 mm, wall thickness 2.7– 15.1 mm, fully or partially filled conduits with cables up to 14 mm diameter	50 mm × 3.6 mm (2 × 1.8 mm layer)		-/90/90 U/C
Diameter up to Ø 40 mm, wall thickness 1.8-2.0 mm with or without cables up to Ø 14 mm, in pipe bundles up to Ø 110 mm ¹⁾	50 mm × 3.6 mm (2 × 1.8 mm layer)		
Uponor Wirsbo PEX double pipe in pipe system			
Diameter up to 54 mm/4.0 mm wall thickness (outer pipe), 28 mm diameter/0.4 mm wall thickness (inner pipe)	50 mm × 3.6 mm (2 × 1.8 mm layer)	1 & 2	-/120/120 C/C

Services	Wraps (both sides)	Permitted configuration for seal separation	FRL
Diameter up to 25 mm pipes, wall thickness 0.6 mm, in bundles up to 50 mm	50 mm × 3.6 mm (2 × 1.8 mm layer)		-/90/90 C/C
Uponor Decibel pipe			
50 mm diameter/2.0 mm wall thickness	50 mm × 3.6 mm (2 × 1.8 mm layer)	1 & 2	-/90/90 U/U
75-110 mm diameter/2.6-3.8 mm wall thickness	50 mm × 3.6 mm (2 × 1.8 mm layer)		-/90/90 U/C
BluePower Multilayer pipe			
32-50 mm diameter/1.8 mm wall thickness*	50 mm × 3.6 mm (2 × 1.8 mm layer)	1 & 2	-/90/90 U/U
75-110 mm diameter/3.4 mm wall thickness*	50 mm × 3.6 mm (2 × 1.8 mm layer)		-/90/90 C/U
125-160 mm diameter/3.9-4.9 mm wall thickness	50 mm × 10.8 mm (6 × 1.8 mm layer)		-/90/90 U/C
Rehau Raupiano Plus PP-DD			
40-50 mm diameter/1.8-2.7 mm wall thickness*	50 mm × 3.6 mm (2 × 1.8 mm layer)	1 & 2	-/120/120 U/U
75-110 mm diameter/2.7 mm wall thickness*	50 mm × 3.6 mm (2 × 1.8 mm layer)		-/120/120 U/C
125 mm diameter/3.9 mm wall thickness	50 mm × 7.2 mm (4 × 1.8 mm layer)		-/120/120 U/C
160 mm diameter/3.9 mm wall thickness	50 mm × 10.8 mm (6 × 1.8 mm layer)		-/120/120 U/C
Polo-Kal NG Poloplast PP-MV			
32-50 mm diameter/2.0-3.4 mm wall thickness*	50 mm × 3.6 mm (2 × 1.8 mm layer)	1 & 2	-/120/120 U/U
75-110 mm diameter/3.4 mm wall thickness*	50 mm × 3.6 mm (2 × 1.8 mm layer)		-/120/120 U/C
125 mm diameter/3.9 mm wall thickness	50 mm × 7.2 mm (4 × 1.8 mm layer)		-/120/120 U/C
160 mm diameter/4.9 mm wall thickness	50 mm × 10.8 mm (6 × 1.8 mm layer)		-/120/120 U/C
Aquatherm Green SDR9 MF PP-RP			
32 mm diameter/3.0 mm wall thickness	50 mm × 3.6 mm (2 × 1.8 mm layer)	1 & 2	-/120/90 C/C
40-50 mm diameter/5.6-12.3 mm wall thickness*	50 mm × 3.6 mm (2 × 1.8 mm layer)		-/120/90 C/C
63-110 mm diameter/12.3 mm wall thickness*	50 mm × 3.6 mm (2 × 1.8 mm layer)		-/120/90 C/C
Wavin SiTech + PP-M B			
32-50 mm diameter/1.8-3.4 mm wall thickness*	50 mm × 3.6 mm (2 × 1.8 mm layer)	1 & 2	-/120/90 U/U

Services	Wraps (both sides)	Permitted configuration for seal separation	FRL
75-110 mm diameter/3.4 mm wall thickness*	50 mm × 3.6 mm (2 × 1.8 mm layer)		-/120/60 U/C
Gilbert Silent PP			
32-50 mm diameter/1.8-3.4 mm wall thickness*	50 mm × 3.6 mm (2 × 1.8 mm layer)	1 & 2	-/120/120 U/U
75-110 mm diameter/3.4 mm wall thickness*	50 mm × 3.6 mm (2 × 1.8 mm layer)		-/120/120 U/C
1) PVC, PE and PP pipes can be mixed in the same bundle. *See below graph for interpolation pipe sizes			

PVC-U Pipes - E 90 C/C, EI 60 C/C

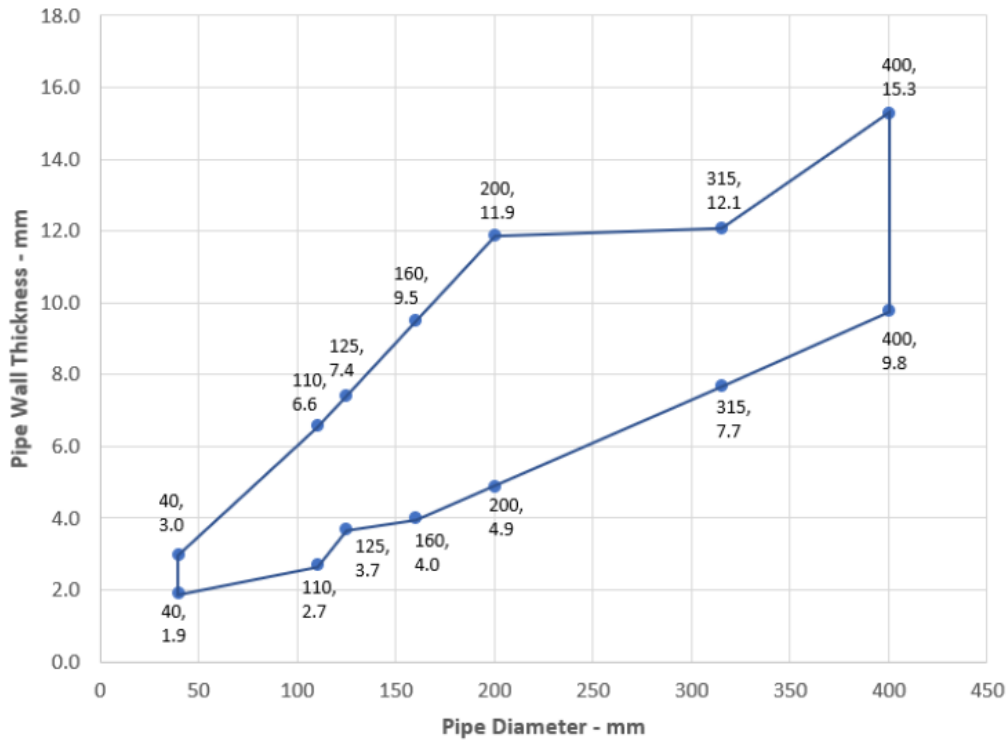

Figure 29 Intermediate pipe wall thicknesses for PVC-U pipe diameters

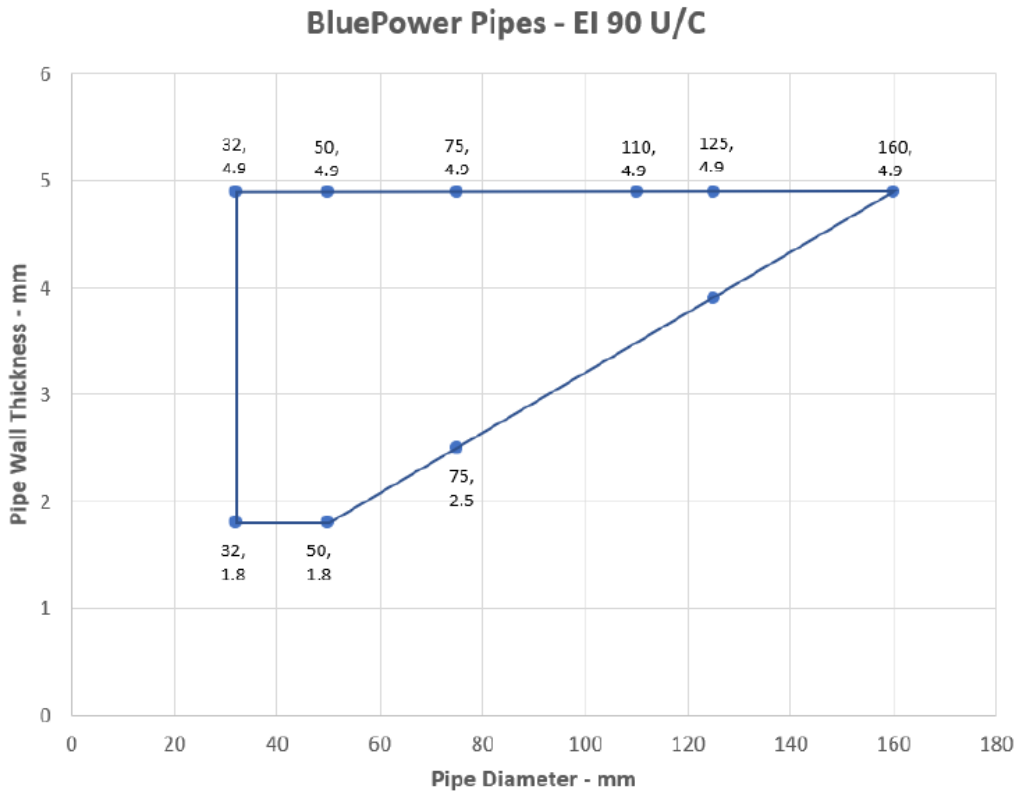

Figure 30 Intermediate pipe wall thicknesses for BluePower pipe diameters

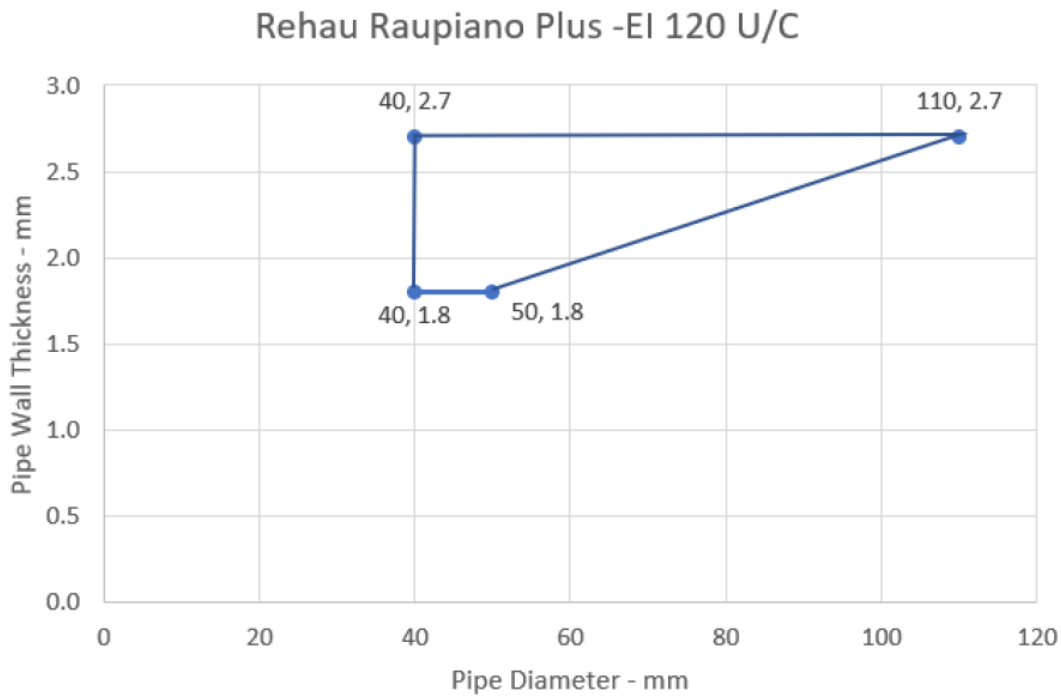

Figure 31 Intermediate pipe wall thicknesses for Rehau Raupiano pipe diameters

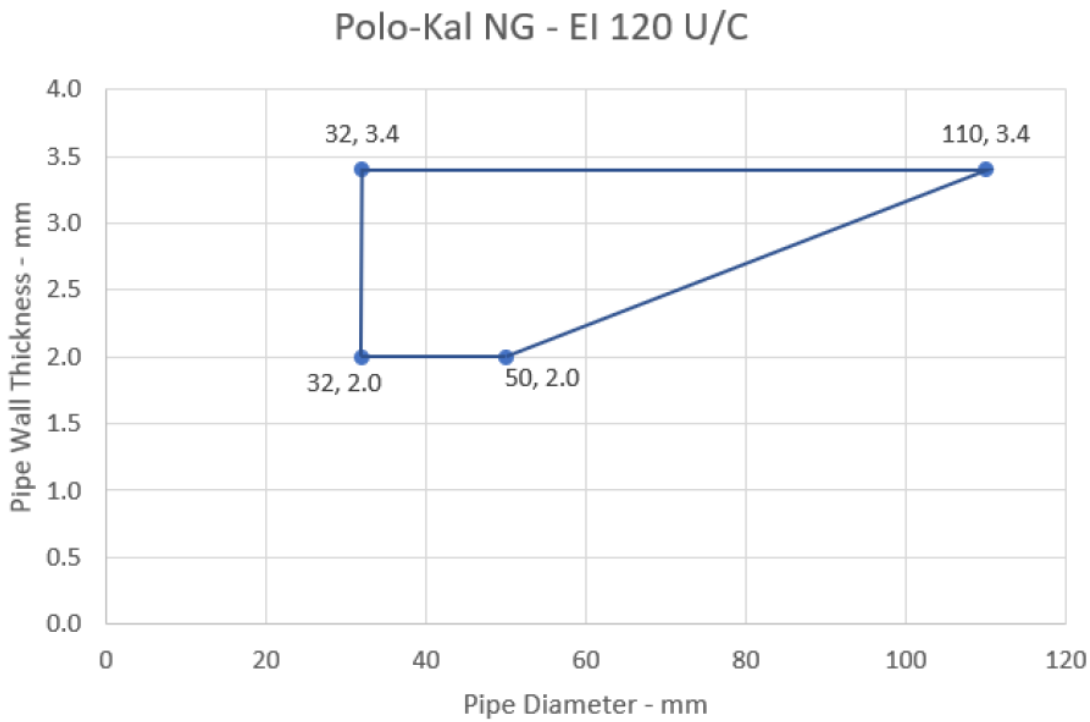

Figure 32 Intermediate pipe wall thicknesses for Polo-Kal NG pipe diameters

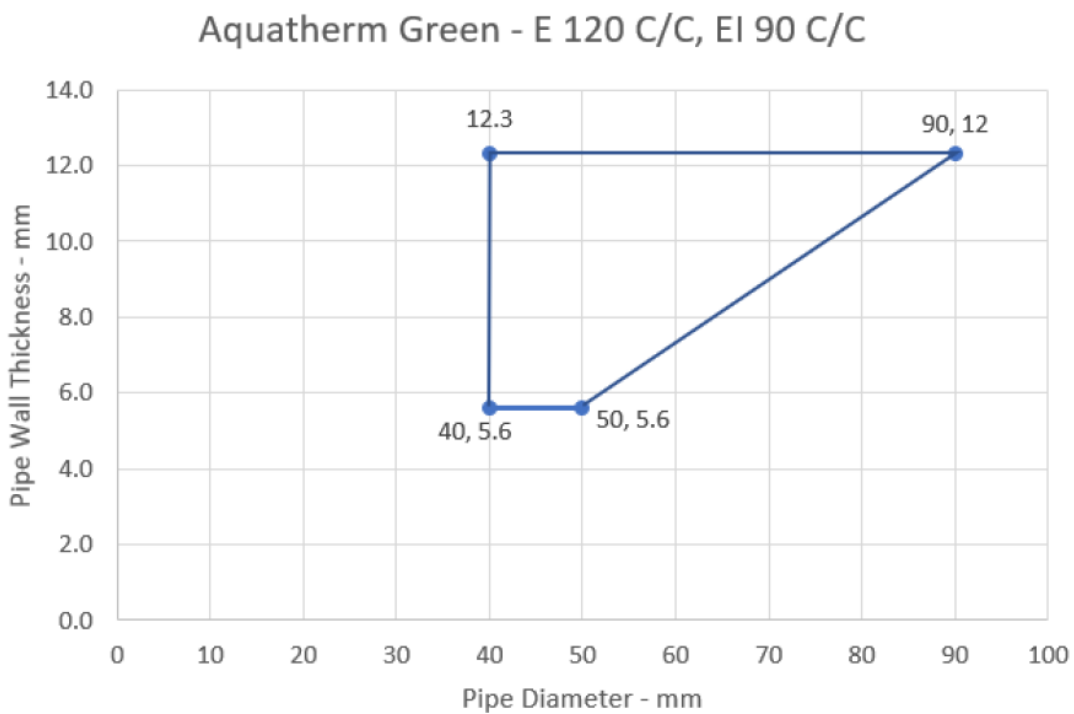

Figure 33 Intermediate pipe wall thicknesses for Aquatherm Green pipe diameters

Wavin SiTech Pipes - E120 C/C, EI 60 C/C

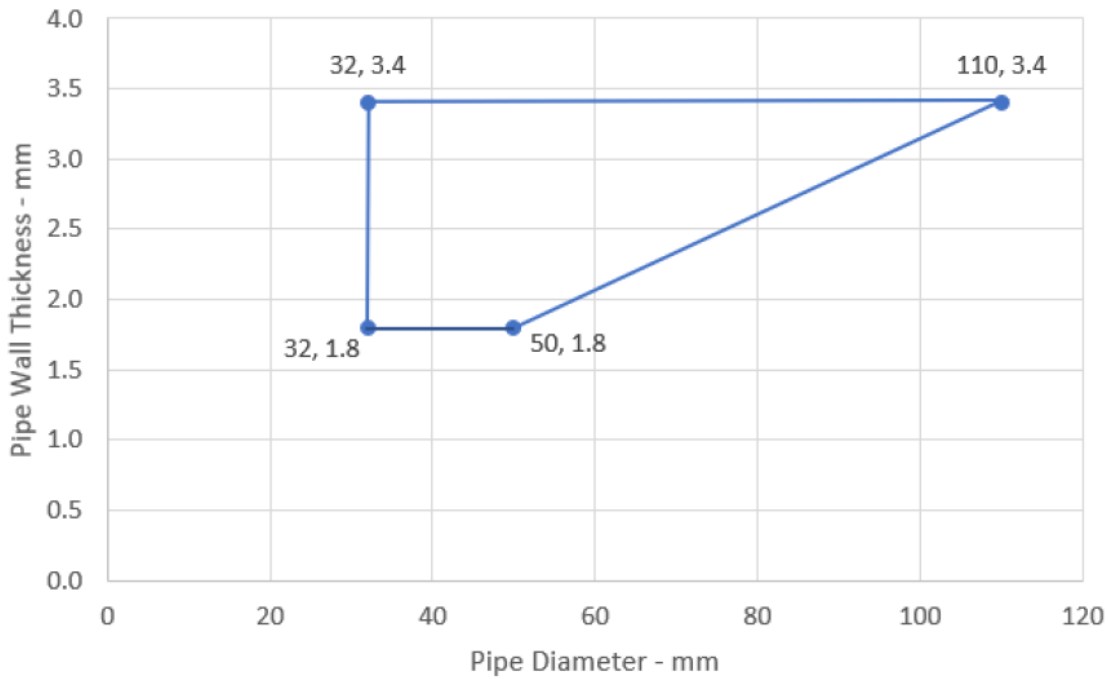

Figure 34 Intermediate pipe wall thicknesses for Wavin SiTech pipe diameters

Gilbert Silent PP - EI 120 U/C

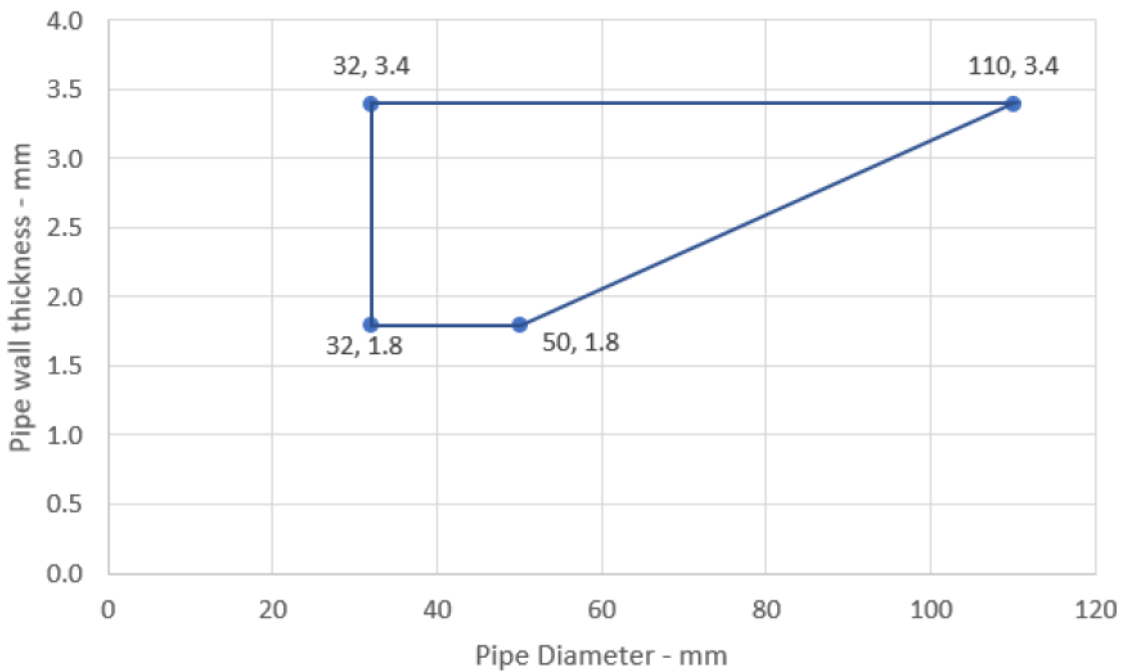

Figure 35 Intermediate pipe wall thicknesses for Gilbert Silent PP pipe diameters

6.3.5.8 *Protecta FR Service Coat FR1 penetration seal for steel pipes, in 2 × Protecta FR Board 1-S in flexible or rigid walls*

Penetration seal:

Metallic pipes with Protecta FR Service Coat FR1 fitted at any position within the aperture, with 50 mm Protecta FR Board 1-S to both sides of the wall. Minimum separation between penetration seals and seal edges of 30 mm. (Configuration 1 & 2).

Construction details:

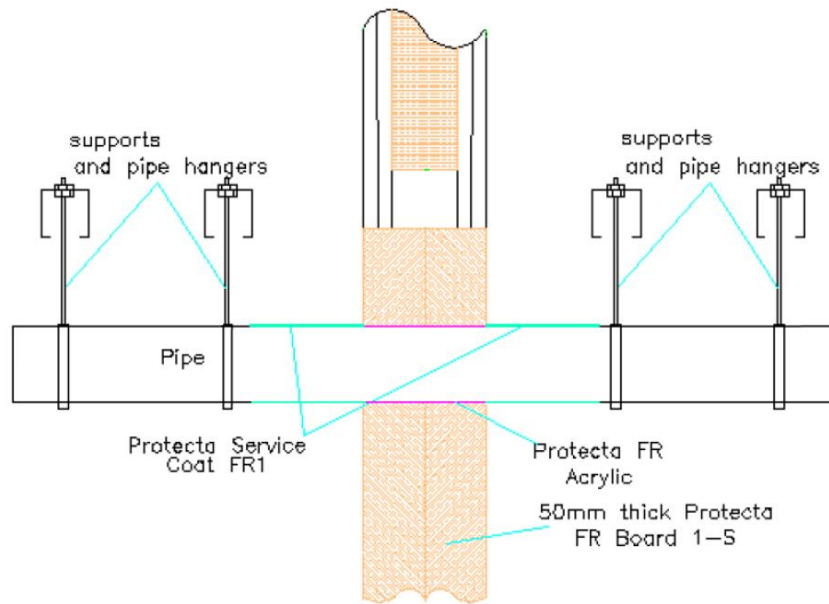

Configuration 1

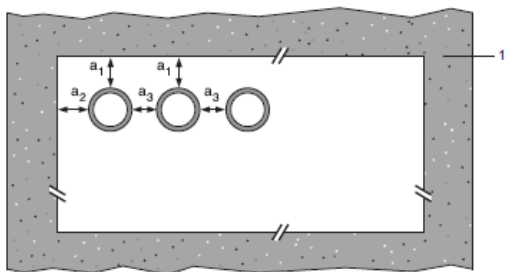

Configuration 2

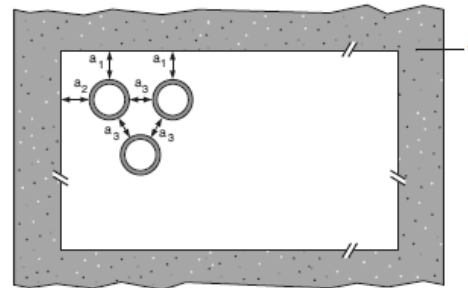

Key:

- 1 Supporting construction
- a₁ Pipe/top edge of seal separation
- a₂ Pipe/side edge of seal separation
- a₃ Pipe/pipe separation

Table 47 Protecta FR Service Coat FR1 penetration seal for steel pipes

Services	Insulation, minimum	FRL
Mild or stainless steel pipe		
Maximum 63 mm diameter*	Protecta FR Service Coat FR-1, 750-micron DFT extending 200 mm from both faces of the Protecta FR Board fire seal	-/120/120 C/C
	Protecta FR Service Coat FR-1, 1500-micron DFT extending 200 mm from both faces of the Protecta FR Board fire seal	-/90/60 C/U
Maximum 114 mm diameter	Protecta FR Service Coat FR-1, 1000-micron DFT extending 200 mm from both faces of the Protecta FR Board fire seal	-/120/45 C/U

*Typical pipe diameters shown, see below graph for intermediate size

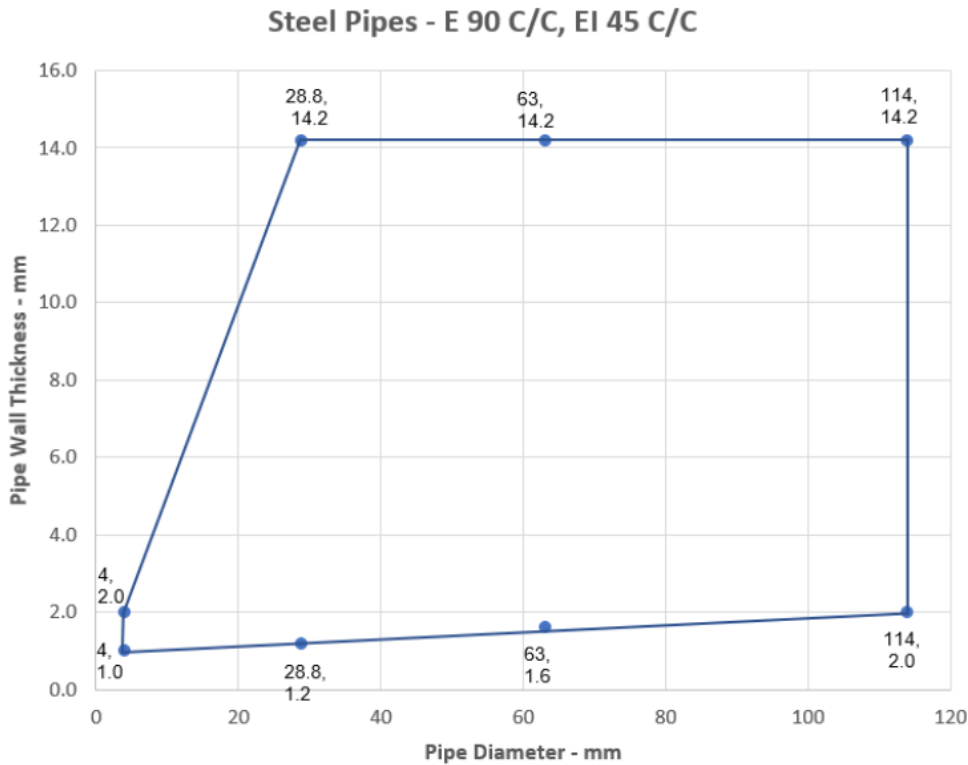

Figure 36 Intermediate pipe wall thicknesses for steel pipe diameters

6.3.5.9 Penetration seal with 1 x Protecta FR Board 50 2-S in framed aperture

Penetration seal:

Services fitted at any position within the aperture, with 50 mm Protecta FR Board 2-S positioned to either face of the wall (or anywhere in between). Minimum 30 mm separation between pipes. Protecta FR collars fixed with 50 mm pigtail screws. Cables and cable trays coated 150mm each side of FR Board with nominally 300µm WFT Protecta Service Coat FR-1. In rigid wall constructions the wall thickness can be minimum 75 mm.

Construction details:

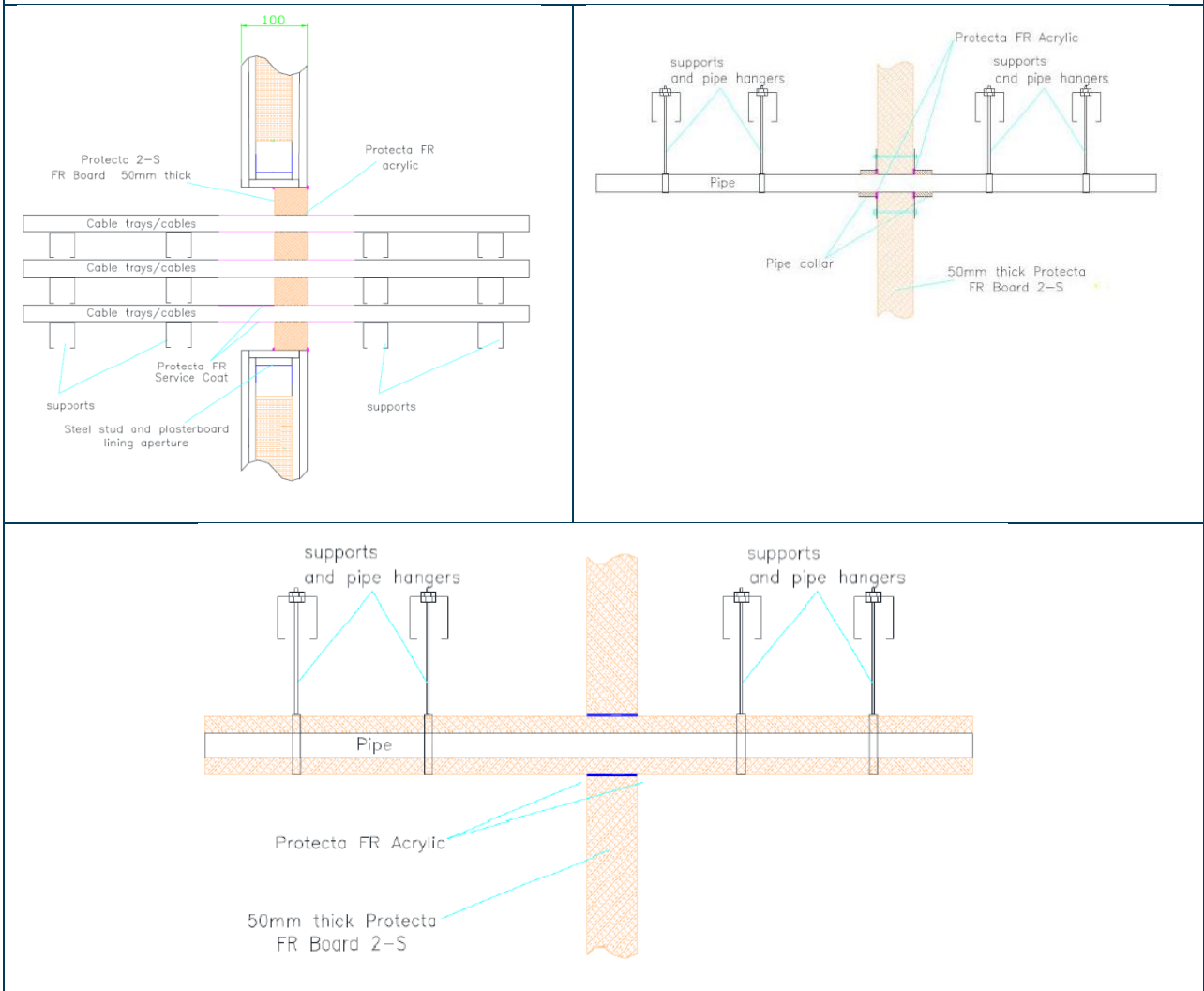

Table 48 Single side penetration seal with cables

Services	Maximum aperture	FRL
Electrical cables up to Ø 80 mm (single, bundled and on trays)	1200 mm wide x 600 mm high	-/60/60
Cables up to Ø 21 mm in tied bundles up to Ø 100 mm		
Perforated Steel cable trays & ladders		-/60/60
Unperforated steel cable trays		-/60/45
Unsheathed wires up to Ø 24 mm		-/60/45

Table 49 Single side penetration seal with mild or stainless steel pipe

Services	Maximum aperture	Insulation – continuous sustained (CS)	FRL
Mild or stainless steel pipe			
40 mm diameter/1.0-14.2 mm wall*	1200mm wide × 600 mm high	20 mm stone wool insulation 80 kg/m ³	-/90/60 C/U
40 mm diameter/1.0-14.2 mm wall*		30 mm stone wool insulation 80 kg/m ³	
50 mm diameter/1.7-14.2 mm wall*			
60 mm diameter/1.8-14.2 mm wall*			
75 mm diameter/2.1-14.2 mm wall*			
90 mm diameter/2.3-14.2 mm wall*			
100 mm diameter/2.5-14.2 mm wall*			
115 mm diameter/2.8-14.2 mm wall*			
140 mm diameter/3.2-14.2 mm wall*			
165 mm diameter/ 3.6-14.2 mm wall*			
180 mm diameter/ 3.9-14.2 mm wall*			
200 mm diameter/ 4.2-14.2 mm wall*			
219 mm diameter/ 4.5-14.2 mm wall*			
250 mm diameter/ 5.0-14.2 mm wall*			
300 mm diameter/ 5.9-14.2 mm wall*			
324 mm diameter/ 6.35-14.2 mm wall*			
*Typical pipe diameters shown, see below graph for intermediate sizes			

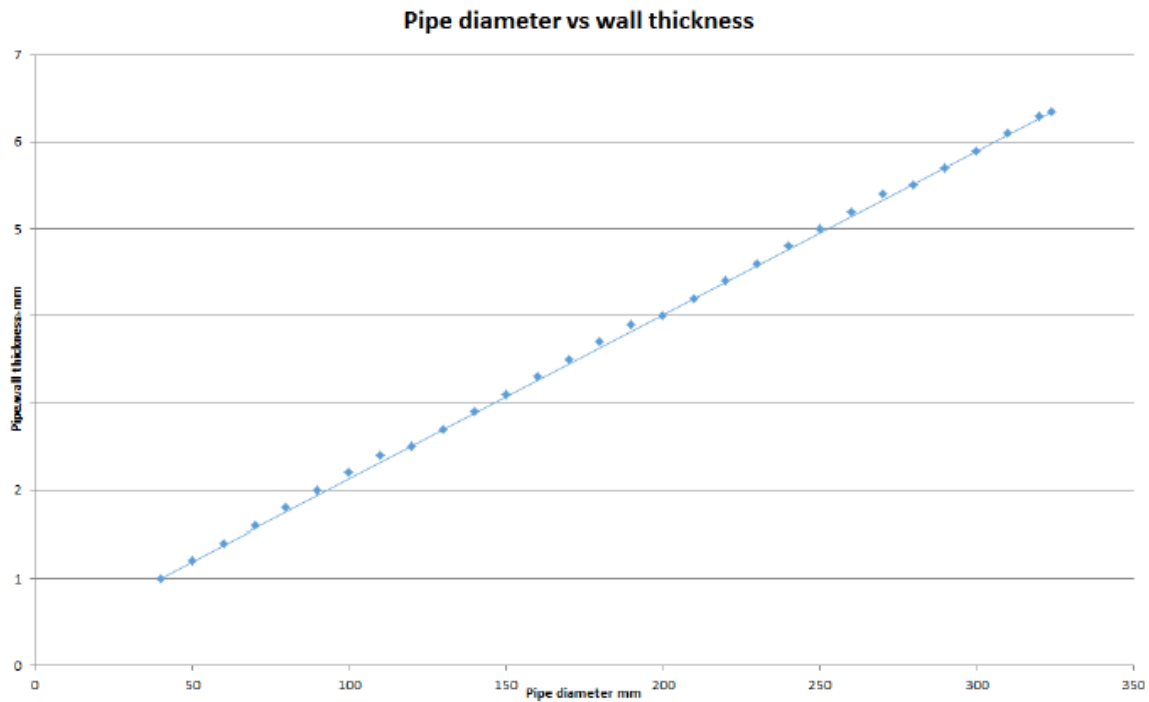

Figure 37 Intermediate pipe wall thicknesses for steel pipe diameters

Table 50 Single side penetration seal with metal pipes

Services	Maximum aperture	Insulation – continuous sustained (CS)	FRL
Copper pipe maximum 54 mm diameter*	1200 mm wide × 600 mm high	20-40 mm glass or stone wool insulation min. 75 kg/m ³	-/60/30 C/C
Alupex pipe maximum 16 mm diameter/2.25 mm wall		20 mm glass or stone wool insulation min. 75 kg/m ³	-/60/30 C/C
Alupex pipe maximum 75 mm diameter/4.6 mm wall		25 mm glass or stone wool insulation min. 75 kg/m ³	-/60/60 C/C
*Typical pipe diameters shown, see below graph for intermediate sizes			

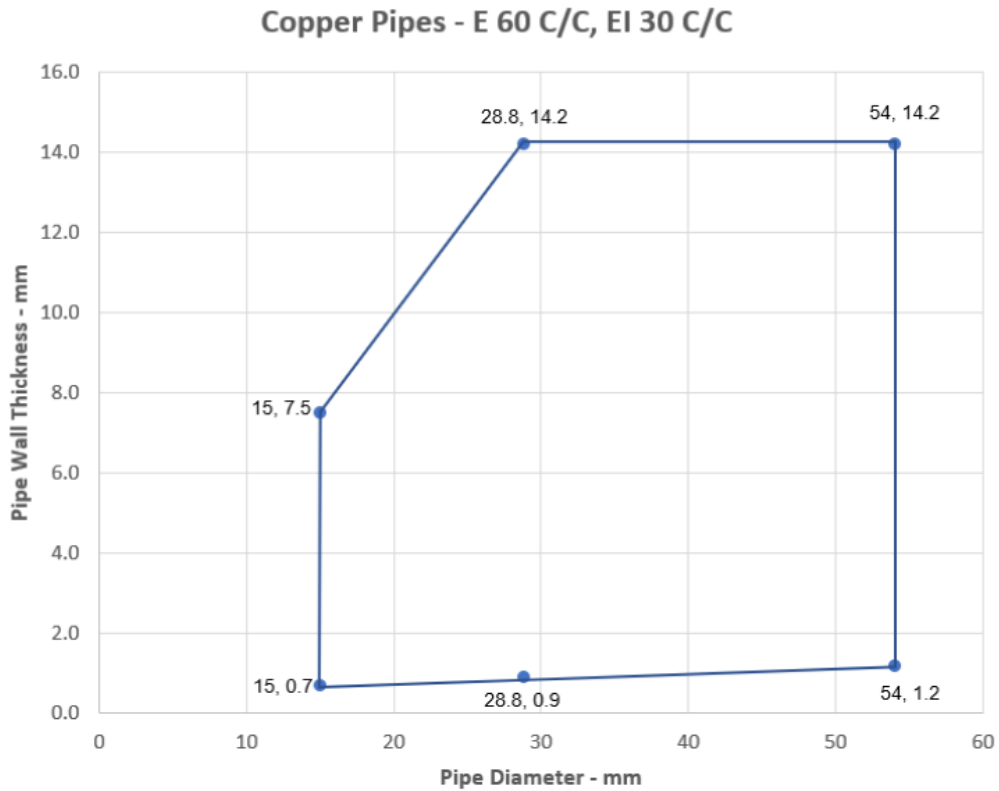

Figure 38 Intermediate pipe wall thicknesses for copper pipe diameters with CS insulation

Table 51 Single side penetration seal with metal pipes

Services	Maximum aperture	Insulation – continuous interrupted (LI or CI)	FRL
Copper pipe maximum 54 mm diameter*	1200 mm wide × 600 mm high	Min. 500 mm length, min. 20 mm thick glass or stone wool insulation 75 kg/m ³	-/60/45 C/C
*Typical pipe diameters shown, see below graph for intermediate sizes			

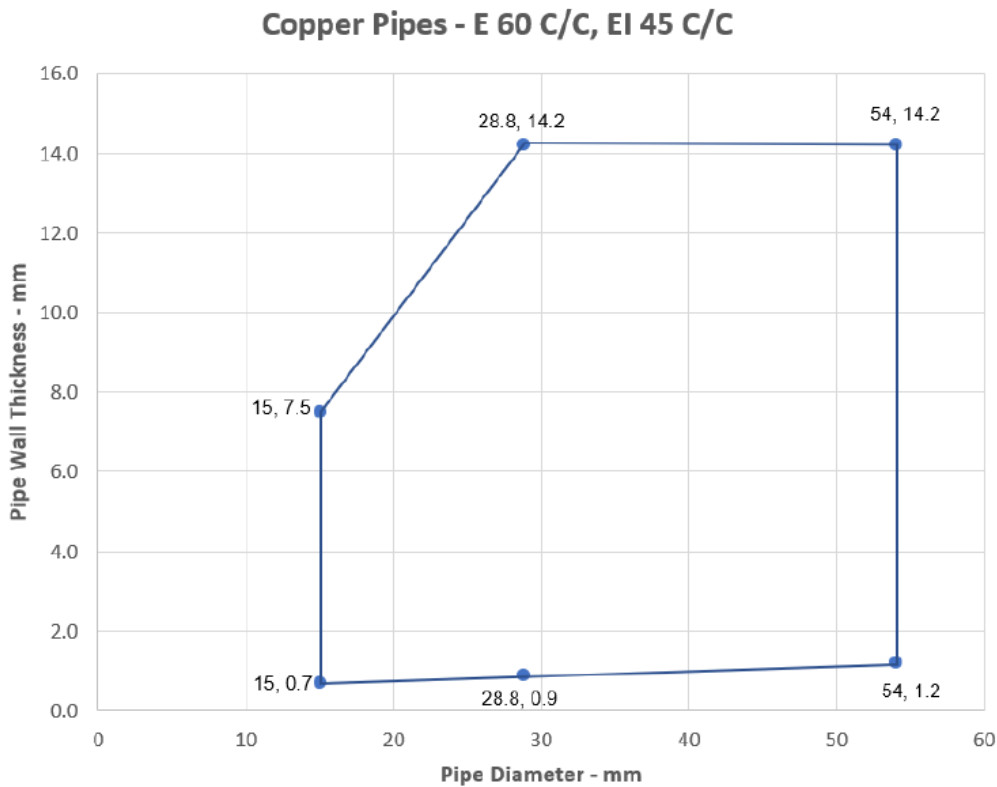

Figure 39 Intermediate pipe wall thicknesses for copper pipe diameters with CI insulation

Table 52 Single side penetration seal with metal pipes

Services	Collar	Insulation – continuous sustained (CS)	FRL
Copper pipe			
Maximum 54 mm diameter*	Maximum 110 mm diameter/50 mm high	9-25 mm elastomeric insulation min. class B-s3, d0 or PE Foam insulation	-/60/30 C/C
Alupex pipe			
Maximum 16 mm diameter, wall thickness 2.25 mm	Maximum 40 mm diameter/50 mm high	9 mm elastomeric insulation min. class B-s3, d0 or PE Foam insulation	-/60/60 C/C
Maximum 75 mm diameter, wall thickness 2.25-4.6 mm	Maximum 110 mm diameter/50 mm high		-/60/45 C/C
Maximum 75 mm diameter, wall thickness 2.25-4.6 mm	125 mm diameter/60mm high	25 mm elastomeric insulation min. class B-s3, d0 or PE Foam insulation	-/60/60 C/C
*See below graph for interpolation pipe sizes			

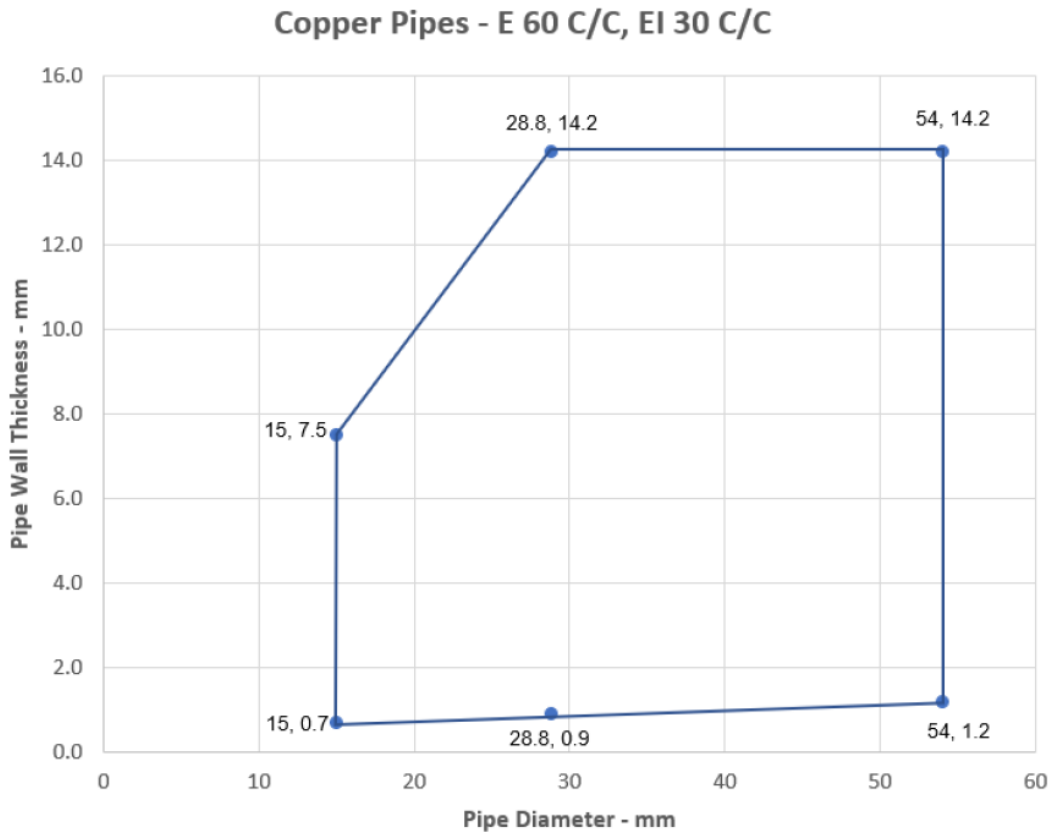

Figure 40 Intermediate pipe wall thicknesses for copper pipe diameters with CS insulation

Table 53 Single side penetration seal with PVC-U pipes

Services	Collar Inlay	FRL
PVC-U pipe		
Diameter 32 mm, wall thickness 1.9 mm	30 × 3.0 mm	-/90/45 U/C
Diameter 40 mm, wall thickness 1.9 mm	30 × 3.0 mm	
Diameter 50 mm, wall thickness 3.7-6.6 mm	30 × 3.0 mm	-/90/30 U/C
Diameter 55 mm, wall thickness 3.7-6.6 mm	30 × 3.2 mm	
Diameter 63 mm, wall thickness 3.7-6.6 mm	30 × 3.6 mm	
Diameter 75 mm, wall thickness 3.7-6.6 mm	30 × 4.2 mm	
Diameter 82 mm, wall thickness 3.7-6.6 mm	30 × 4.6 mm	
Diameter 90 mm, wall thickness 3.7-6.6 mm	30 × 5.0 mm	
Diameter 110 mm, wall thickness 2.7-6.6 mm	30 × 6.0 mm	
32 mm diameter*	50 × 3.0 mm	-/120/60 U/C
40 mm diameter*	50 × 3.0 mm	
50 mm diameter*	50 × 3.0 mm	
55 mm diameter*	50 × 3.2 mm	-/90/60 U/C
63 mm diameter*	50 × 3.6 mm	

Services	Collar Inlay	FRL
75 mm diameter*	50 × 4.2 mm	
82 mm diameter*	50 × 4.6 mm	
90 mm diameter*	50 × 5.0 mm	
110 mm diameter*	50 × 6.0 mm	
125 mm diameter*	60 × 9.0 mm	-/60/60 C/C
140 mm diameter*	60 × 11.5 mm	
160 mm diameter*	60 × 15.0 mm	

*See below graph for interpolation pipe sizes

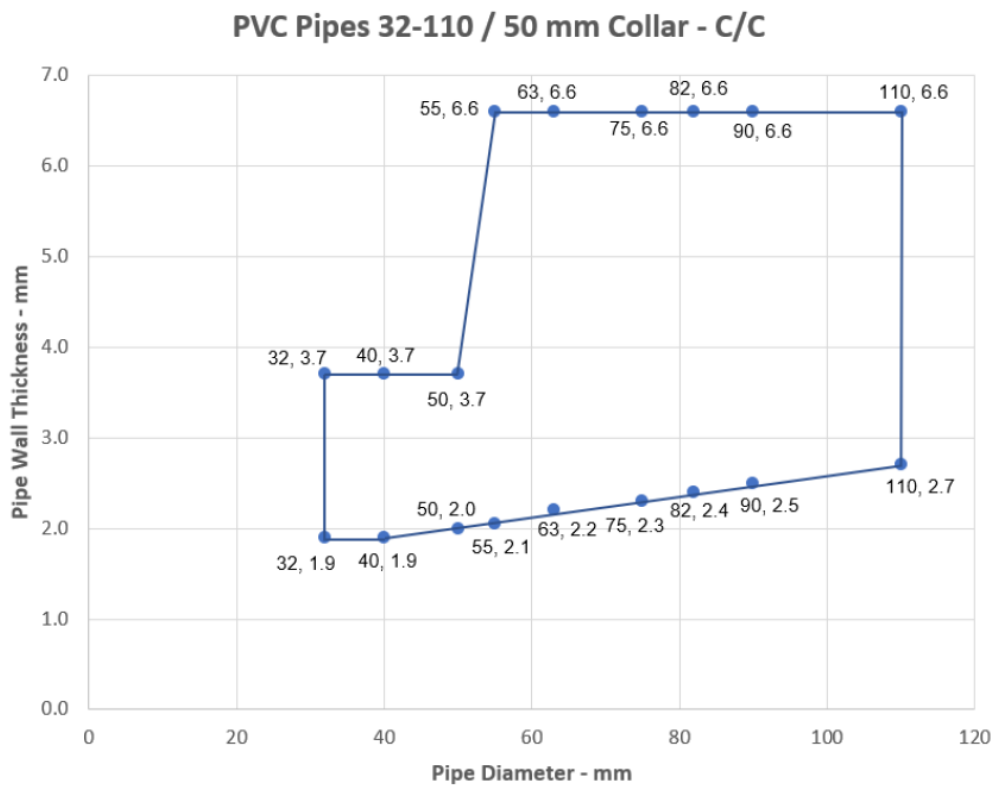

Figure 41 Intermediate pipe wall thicknesses for PVC pipe diameters 32 mm – 110 mm

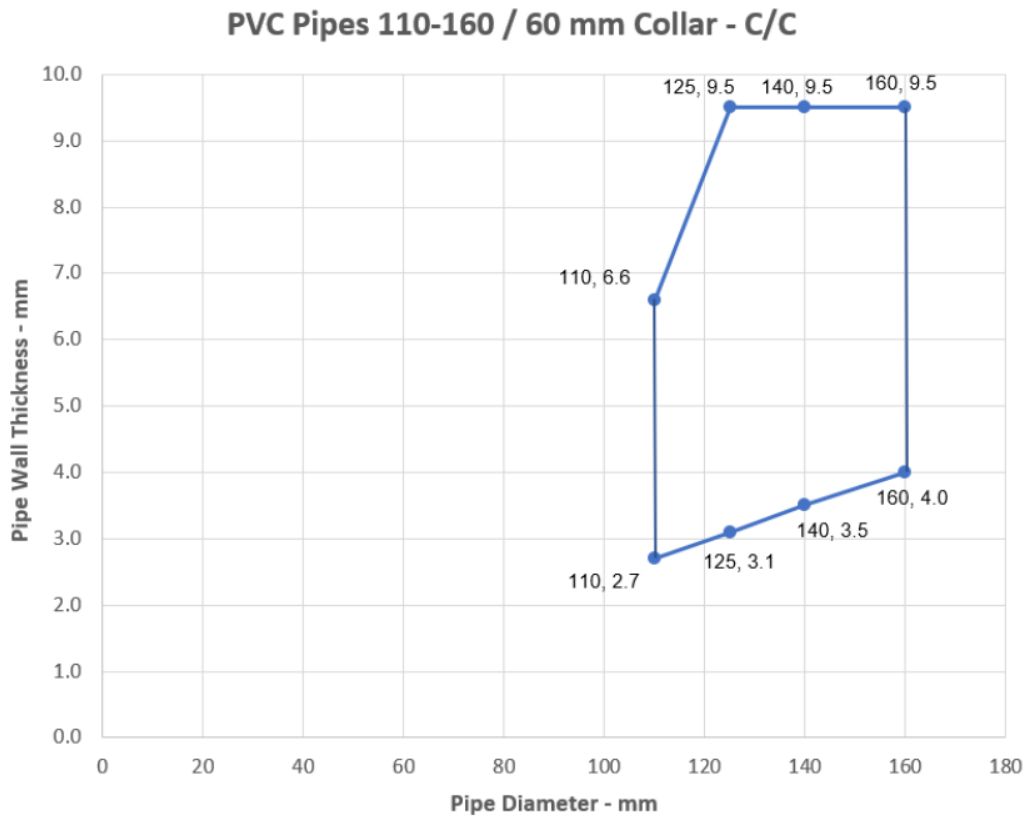

Figure 42 Intermediate pipe wall thicknesses for PVC pipe diameters 110 mm – 160 mm

Table 54 Single side penetration seal with PE pipes

Services	Collar Inlay	FRL
PE pipe		
Diameter 32 mm, wall thickness 3.4-10.0 mm	30 × 3.0 mm	-/60/30 U/C
Diameter 40 mm, wall thickness 3.4-10.0 mm	30 × 3.0 mm	
Diameter 50 mm, wall thickness 3.4-10.0 mm	30 × 3.0 mm	
Diameter 55 mm, wall thickness 3.4-10.0 mm	30 × 3.2 mm	
Diameter 63 mm, wall thickness 3.4-10.0 mm	30 × 3.6 mm	
Diameter 75 mm, wall thickness 3.4-10.0 mm	30 × 4.2 mm	
Diameter 82 mm, wall thickness 3.4-10.0 mm	30 × 4.6 mm	
Diameter 90 mm, wall thickness 3.4-10.0 mm	30 × 5.0 mm	
Diameter 110 mm, wall thickness 3.4-10.0 mm	30 × 6.0 mm	
32 mm diameter*	50 × 3.0 mm	-/120/60 U/C
40 mm diameter*	50 × 3.0 mm	
50 mm diameter*	50 × 3.0 mm	
55 mm diameter*	50 × 3.2 mm	-/90/60 U/C
63 mm diameter*	50 × 3.6 mm	
75 mm diameter*	50 × 4.2 mm	

Services	Collar Inlay	FRL
82 mm diameter*	50 × 4.6 mm	-/60/60 C/C
90 mm diameter*	50 × 5.0 mm	
110 mm diameter*	50 × 6.0 mm	
125 mm diameter*	60 × 9.0 mm	
140 mm diameter*	60 × 11.5 mm	
160 mm diameter*	60 × 15.0 mm	

*See below graph for interpolation pipe sizes

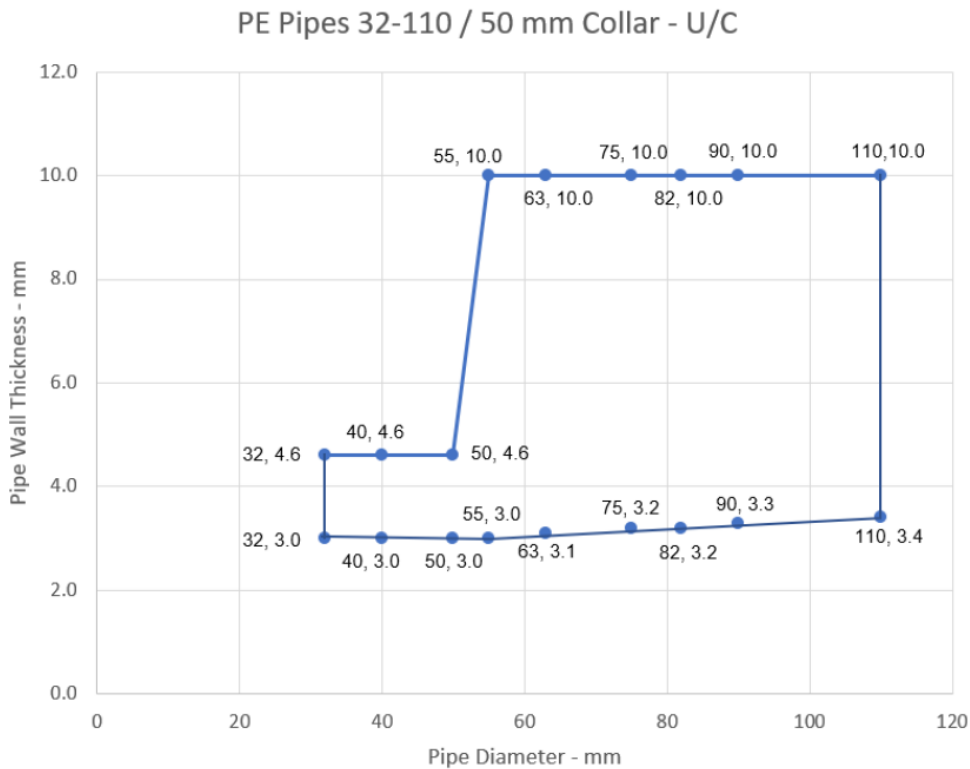

Figure 43 Intermediate pipe wall thicknesses for PE pipe diameters 32 mm – 110 mm

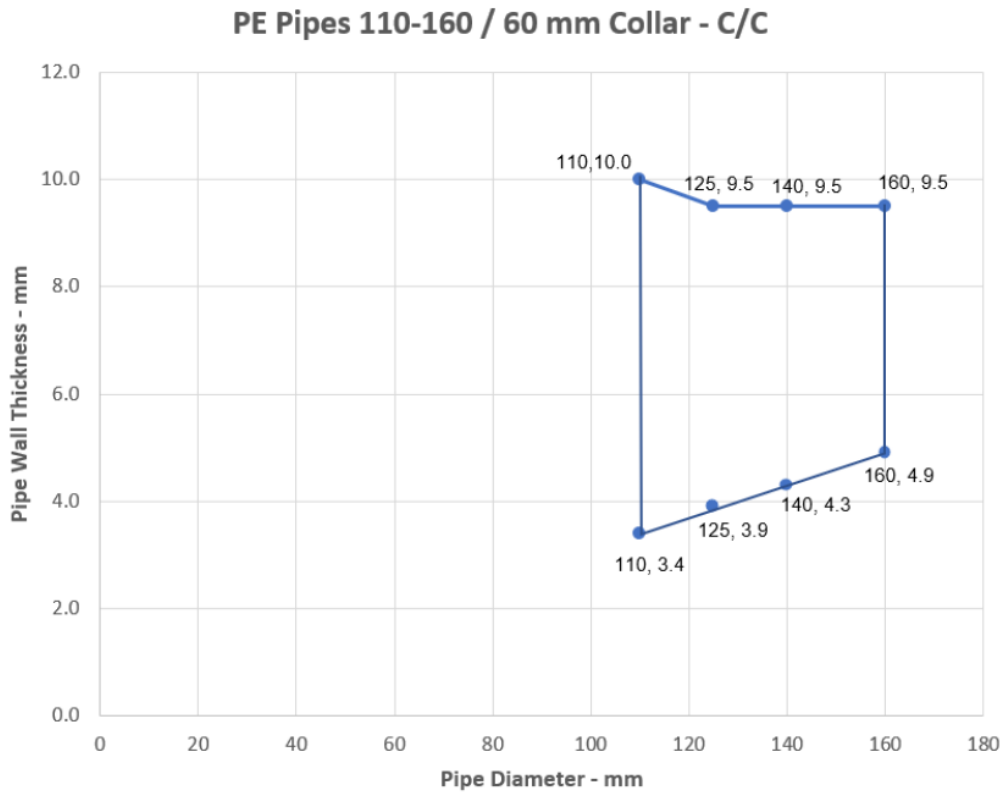

Figure 44 Intermediate pipe wall thicknesses for PE pipe diameters 110 mm – 160 mm

Table 55 Single side penetration seal with PP pipes

Services	Collar Inlay	FRL
PP pipe		
32 mm diameter*	50 × 3.0 mm	-60/60 C/C
40 mm diameter*	50 × 3.0 mm	
50 mm diameter*	50 × 3.0 mm	
55 mm diameter*	50 × 3.2 mm	
63 mm diameter*	50 × 3.6 mm	
75 mm diameter*	50 × 4.2 mm	
82 mm diameter*	50 × 4.6 mm	
90 mm diameter*	50 × 5.0 mm	
110 mm diameter*	50 × 6.0 mm	
125 mm diameter*	60 × 9.0 mm	
140 mm diameter*	60 × 11.5 mm	
160 mm diameter*	60 × 15.0 mm	
*See below graph for interpolation pipe sizes		

PP Pipes 32-110 / 50 mm Collar - C/C

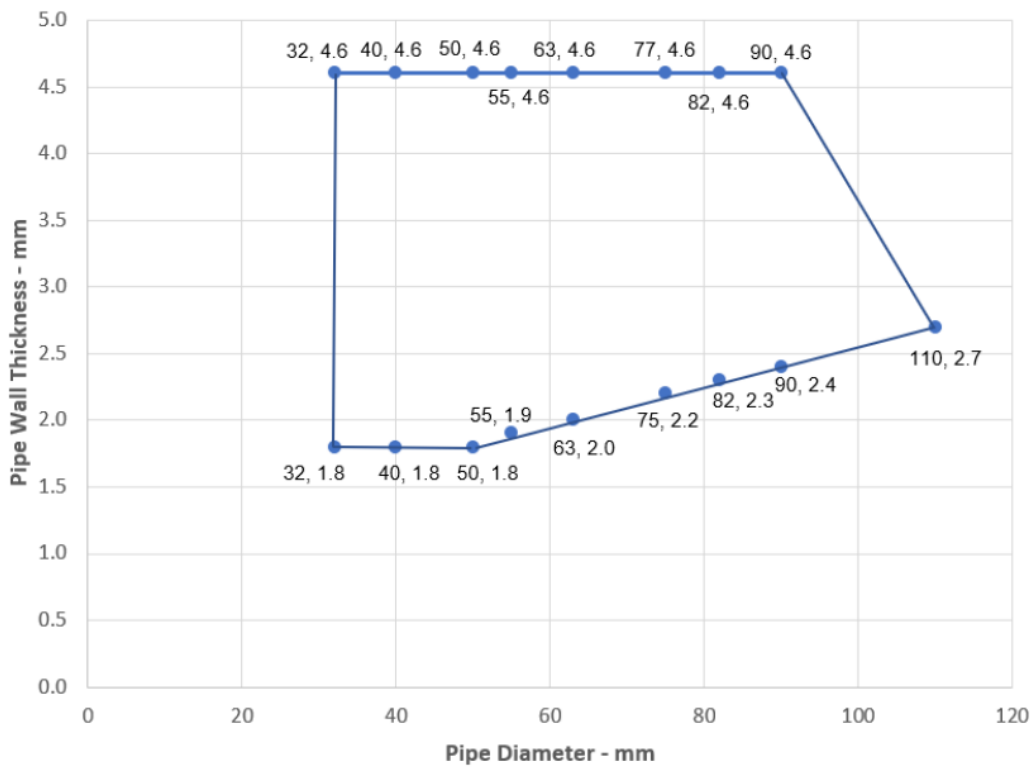

Figure 45 Intermediate pipe wall thicknesses for PP pipe diameters 32 mm – 110 mm

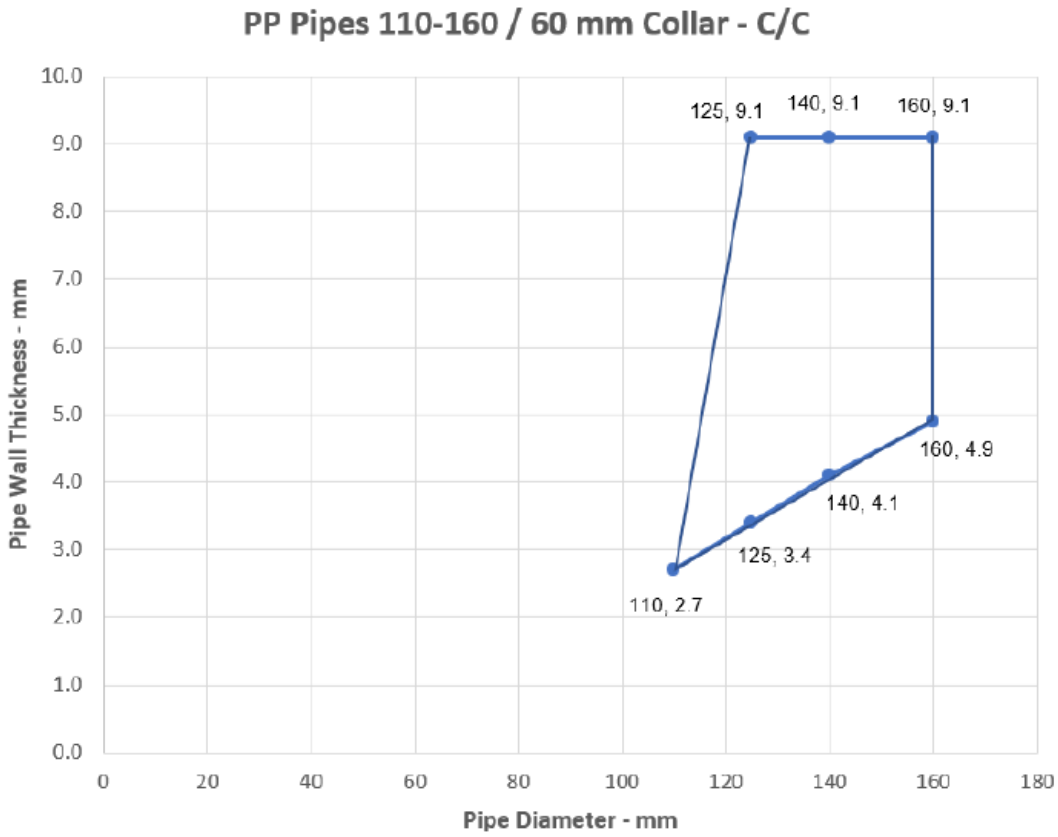

Figure 46 Intermediate pipe wall thicknesses for PP pipe diameters 110 mm – 160 mm

6.3.6 Flexible or rigid wall constructions according section 4.1 2 with wall thickness of minimum 120 mm

6.3.6.1 Plastic pipe penetration seal with 2 × Protecta FR Board 2-S

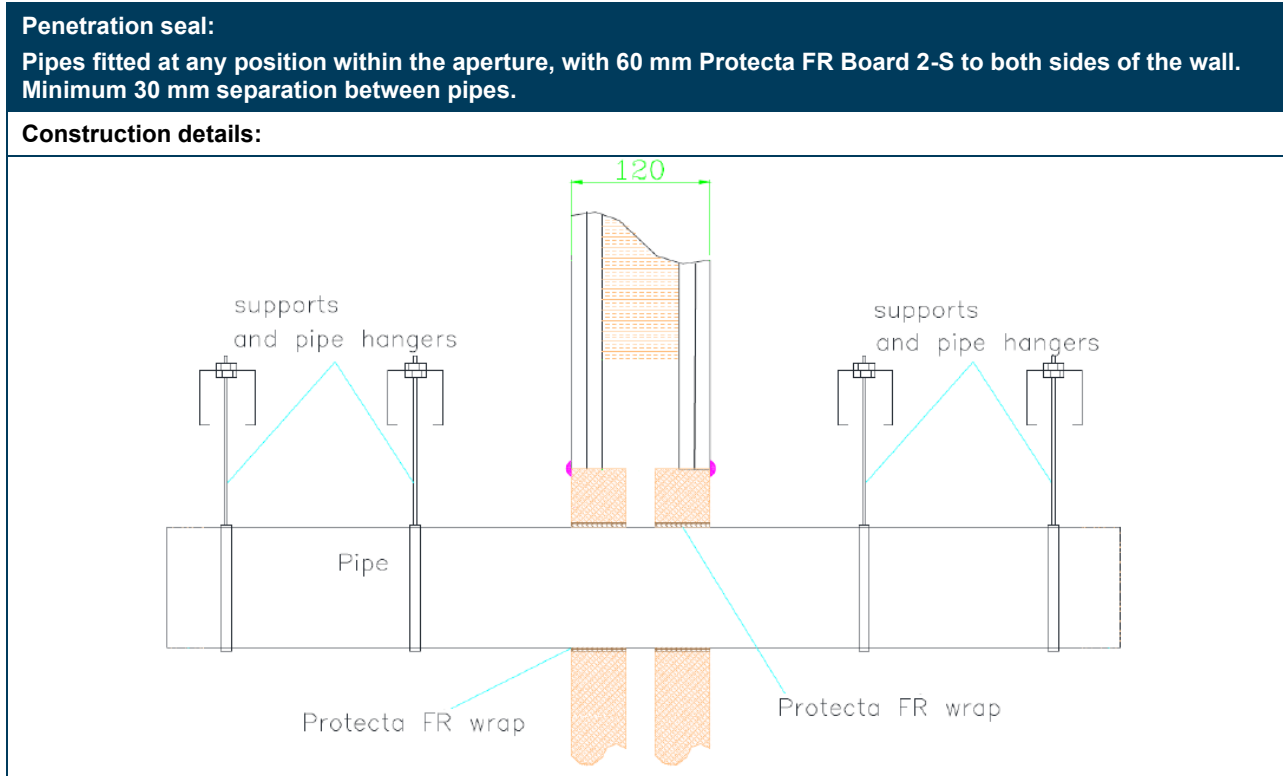

Table 56 Double side penetration seal with plastic pipes

Services	Wraps (both sides)	Permitted configuration for seal separation	FRL
PVC-U pipe			
Diameter up to 40 mm, wall thickness 1.9-3.0 mm	50 mm × 3.6 mm (2 × 1.8 layer)	1 & 2	-120/120 C/C
Diameter up to 110 mm, wall thickness 2.7-6.6 mm	50 mm × 3.6 mm (2 × 1.8 layer)		
Diameter up to 160 mm, wall thickness 4.0-9.5 mm	50 mm × 10.8 mm (6 × 1.8 layer)		
PE pipe			
Diameter up to 40 mm, wall thickness 2.4-4.6 mm	50 mm × 1.8 mm (1 × 1.8 layer)	1 & 2	-120/120 C/C
Diameter up to 110 mm, wall thickness 3.4-10.0 mm	50 mm × 3.6 mm (2 × 1.8 layer)		
Diameter up to 160 mm, wall thickness 4.9-14.6 mm	50 mm × 10.8 mm (6 × 1.8 layer)		
PP pipe			
Diameter up to 40 mm, wall thickness 1.8-5.5 mm	50 mm × 1.8 mm (1 × 1.8 layer)	1 & 2	-120/120 C/C

Services	Wraps (both sides)	Permitted configuration for seal separation	FRL
Diameter up to 110 mm, wall thickness 2.7-10.0 mm	50 mm × 3.6 mm (2 × 1.8 layer)		
Diameter up to 160 mm, wall thickness 4.9-14.6 mm	50 mm × 10.8 mm (6 × 1.8 layer)		

*See below graph for interpolation pipe sizes

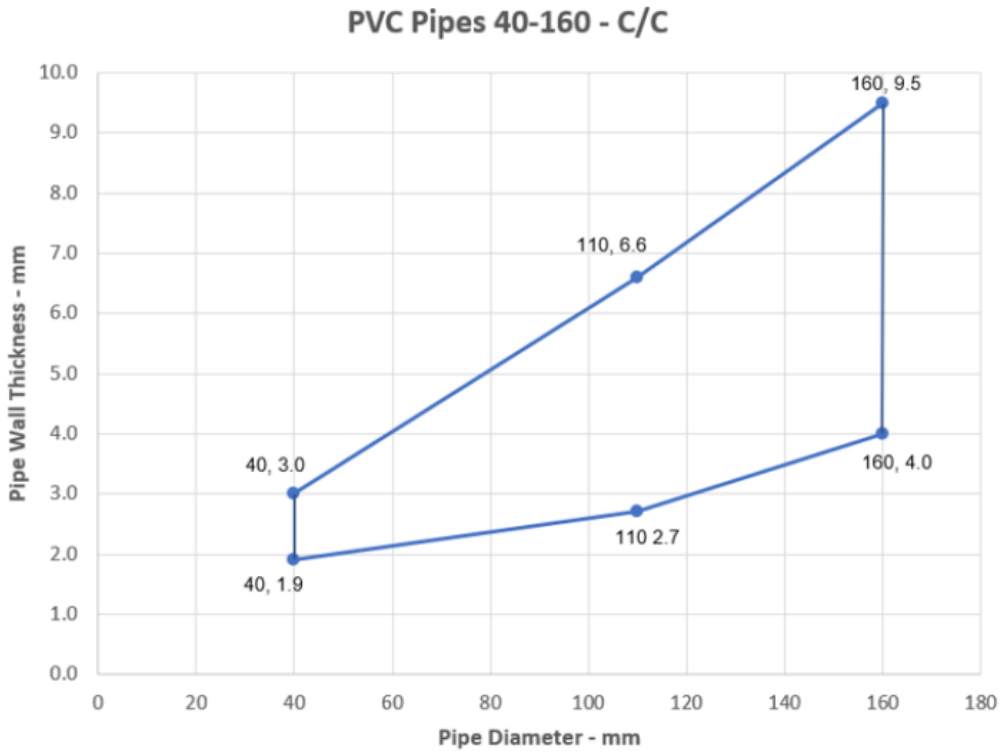

Figure 47 Intermediate pipe wall thicknesses for PVC pipe diameters 40 mm – 160 mm

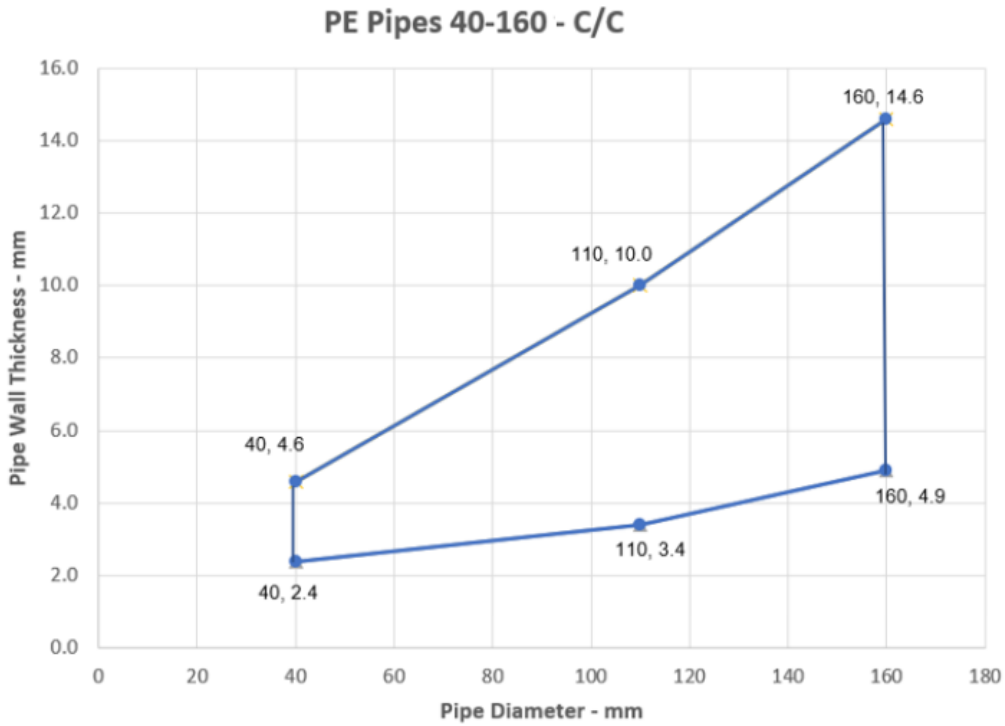

Figure 48 Intermediate pipe wall thicknesses for PE pipe diameters 40 mm – 160 mm

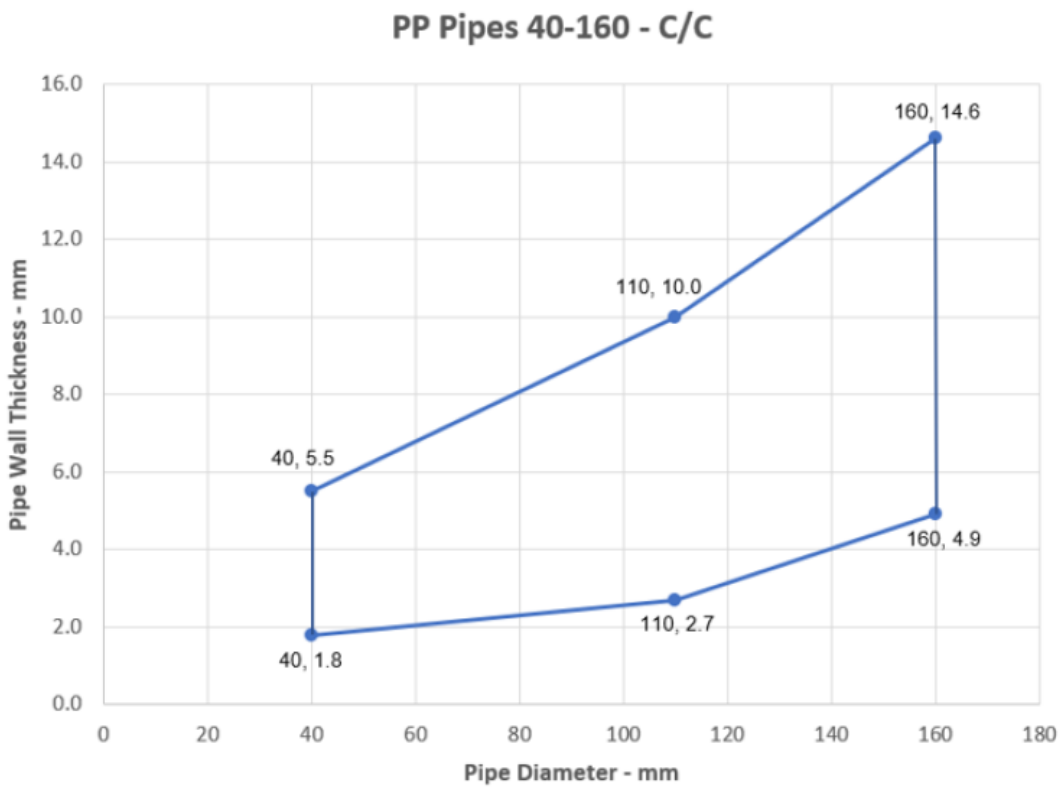

Figure 49 Intermediate pipe wall thicknesses for PP pipe diameters 40 mm – 160 mm

6.3.6.2 Metallic pipe penetration seal with 2 × Protecta FR Board 1-S

Penetration seal:

Metallic pipes fitted at any position within the aperture, with 50 mm Protecta FR Board 1-S to both sides of the wall. Minimum separation between penetration seals and seal edges of 30 mm. (Configuration 1 & 2).

Construction details:

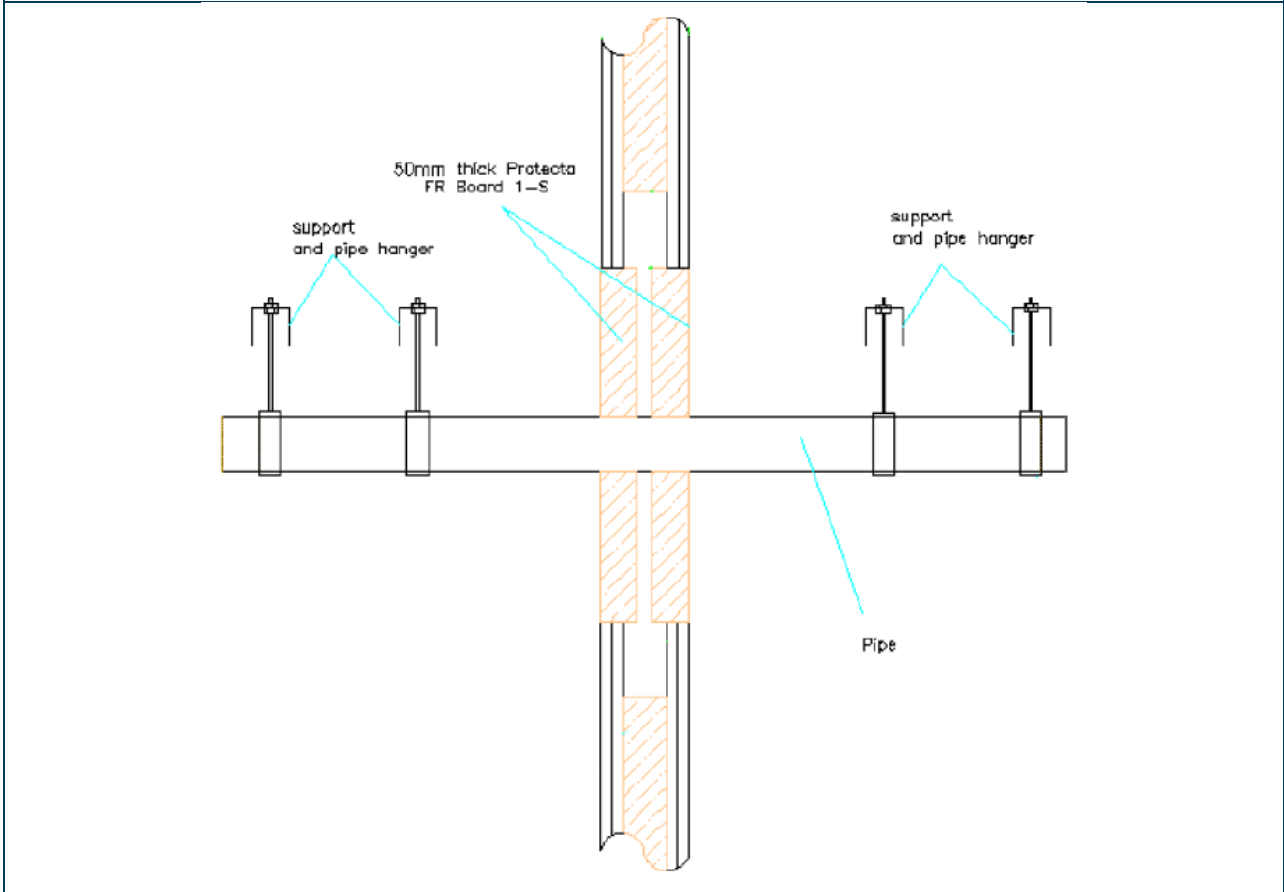

Table 57 Double side penetration seal with metallic pipes

Services	Insulation	Permitted configuration for seal separation	FRL
Mild or stainless steel pipe			
Maximum 63 mm diameter*	None	1 & 2	-/120/30 C/U
63-324 mm diameter*			-/120/- C/U
Copper, mild or stainless steel pipe			
12 mm diameter /0.7-6.0 mm wall thickness	None	1 & 2	-/120/30 C/C
12-54 mm diameter*			-/120/- C/C
Alupex pipe			
Maximum 75 mm diameter*	None	1 & 2	-/120/- C/C
*See below graph for interpolation pipe sizes			

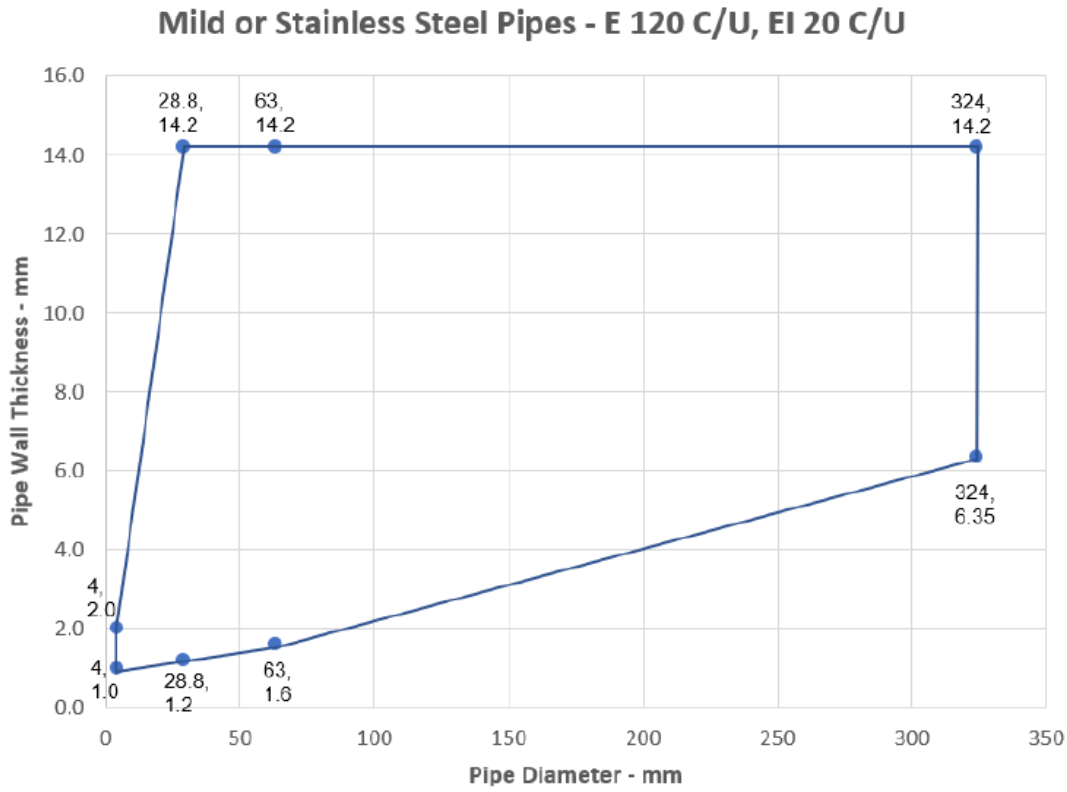

Figure 50 Intermediate pipe wall thicknesses for steel pipe diameters

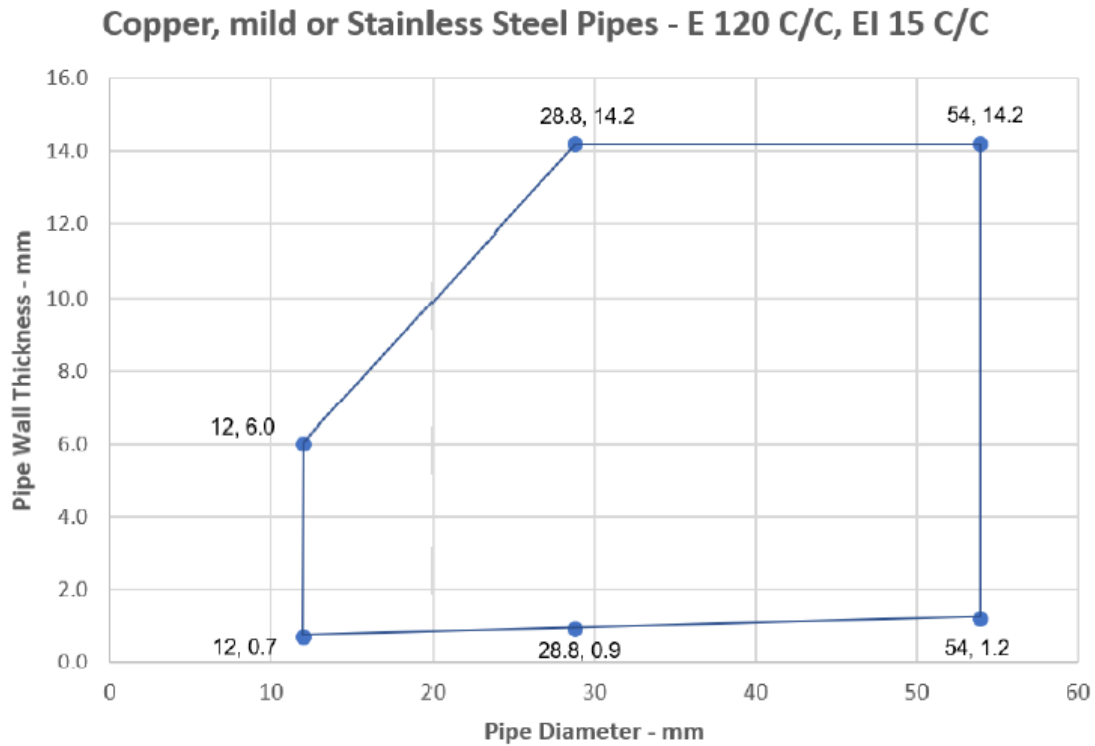

Figure 51 Intermediate pipe wall thicknesses for copper or steel pipe diameters

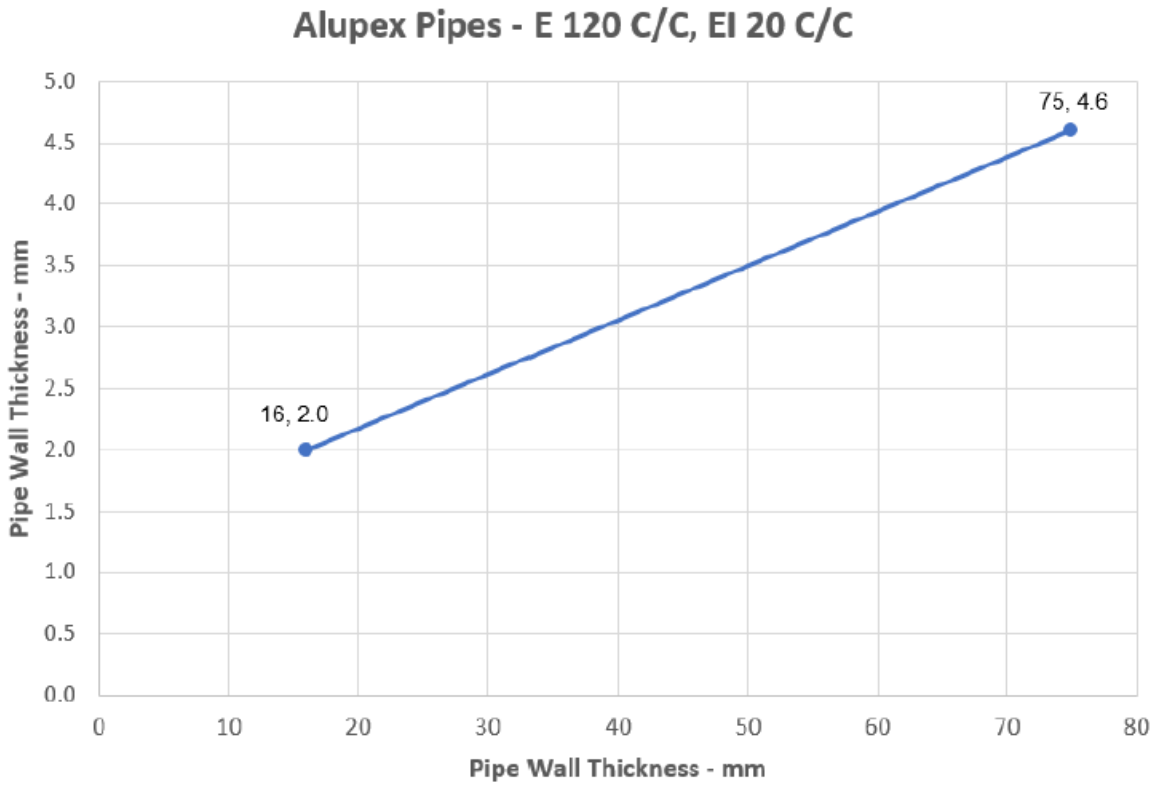

Figure 52 Intermediate pipe wall thicknesses for Alupex pipe diameters

6.3.7 Timber wall constructions according to section 4.1 2 with wall thickness of minimum 100 mm

6.3.7.1 FR Board 50 mm 1-S penetration seal (pattress) with cables

Penetration seal:

Cables fitted at any position within the aperture, with 50 mm Protecta FR Board 1-S to both sides of the wall. Boards to be pattress fixed with 100 mm wood screws and penny washers at 300 mm centres and with a minimum 100 mm overlap around the opening.

Construction details:

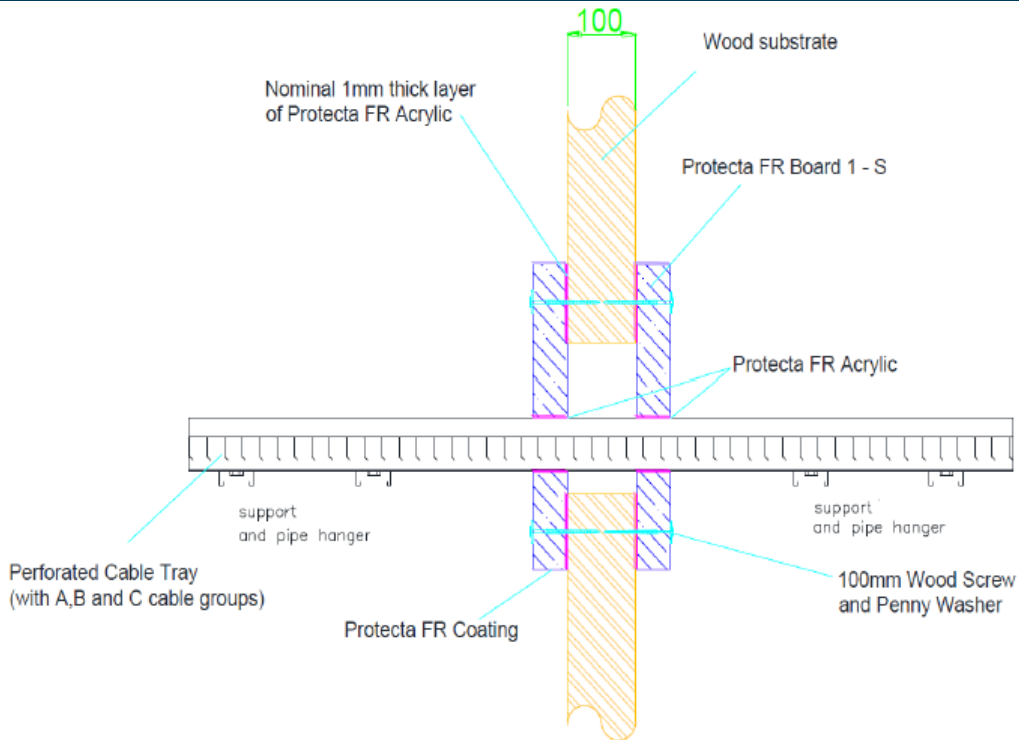

Density must be minimum 480 kg/m³ and the adhesive used must be in the family of heat-resistant melamine-urea-formaldehyde. The outer lamella thicknesses must be equal to or greater than 18.5 mm.

Table 58 Two side penetration seal with cables

Services	Maximum aperture	FRL
Electrical cables up to Ø 21 mm (single, bundled and on trays)	1200 mm × 600 mm	-/120/90
Electrical cables up to Ø 50 mm (single, bundled and on trays)		

7.0 Assessment 3 – Assessment of specific variations

7.1 Description of variation

The tested systems are to be varied as given in section 4.3.

7.2 Methodology

The method of assessment used is summarised in Table 59.

Table 59 Method of assessment

Assessment method	
Level of complexity	Complex assessment
NCC procedure for determining fire performance	Differs in only a minor degree from a tested prototype S1C2(b) and S1C2(c)
Type of assessment	Qualitative and comparative

7.3 Assessment

7.3.1 Proposed variations

It is proposed that the separating elements are varied as follows:

- + The aperture size protected with FR boards is increased
- + The plasterboard wall partition tested in the referenced tests shall include the option of lining with two layers of 13 mm thick fire grade plasterboard that has otherwise been tested or assessed as a wall to achieve a FRL -/120/120 on each side of steel or timber framed wall.
- + The tested 50 mm thick stone wool cavity insulation can be provided as an option.
- + Applying test results obtained to masonry, AAC or concrete walls and bare rigid walls having minimum thickness of 75 mm.
- + The floor thickness is to be varied to 100 mm.
- + It is proposed that the integrity rating achieved for insulated pipes can be applied to uninsulated pipes.

It is also proposed that the fire performance achieved by services penetrating FR boards can be extended to services in core-drilled holes with maximum annular gap of 30 mm in rigid walls and floors protected with FR Pipe Wraps. The rest of the annular gap is to be filled with FR Acrylic sealant.

Increase in aperture size

It is proposed that the system Protecta FR boards may be used to seal apertures in the separating element up to unlimited width and 1200 mm high in a wall, and 2400 mm by 1200 mm in a floor. The additional sizes that are permitted in floors are:

Where 2400 mm × 1200 mm is specified in section 7.0:

Width (mm)	Length (mm)
1100	2900
1000	2880
≤800	∞ (infinite)

Where 1200 mm × 600 mm is specified in section 7.0:

Width (mm)	Length (mm)
500	1800
≤800	∞ (infinite)

The maximum aperture size tested with FR boards is 2400 mm long by 1200 mm wide – in test UL 4788787025. Considering the plan dimensions of the aperture, the aspect ratio is 2:1 which indicates that it can be considered as a one-way slab in which the bending is primarily about the long axis. Provided that the dimensions of the aperture are increased so that the aspect ratio is equal to or greater than 2:1, the Protecta FR board will act as a one-way slab with the same load paths as the tested blank seal. This means that all loads applied onto the aperture will be transferred along the same supporting edges (long edges) as that of the tested system and so the FR board is not expected to detach from the edges and will remain in place. Therefore, the integrity of the seal is not expected to be detrimentally affected with the proposed increase in dimensions.

Variations to plasterboard lined wall

It is proposed that the plasterboard wall partition tested in the referenced tests shall include the option of lining with two layers of 13 mm thick fire grade plasterboard that has otherwise been tested or assessed as a wall to achieve a FRL -/120/120 on each side of steel or timber framed wall.

It is also proposed that the tested 50 mm thick stone wool cavity insulation can be provided as an option.

With reference to tested configurations in the mentioned tests, although the wall was insulated with 50 mm thick stone wool in the wall cavity, the stone wool insulation was cut back for a distance of 100 mm around the openings in the flexible wall.

When tested, the temperature rise measured on the unexposed side of the wall 25 mm from the seal edge in WF 375339 was 21K at 120 minutes, this observation is also in line with the overall unexposed side temperature measurements on other locations of the wall specimen.

Based on the above observation, it is expected that the insulation performance of the plasterboard lined wall without wall cavity insulation would still be maintained for at least 120 minutes. It is therefore considered the proposed construction including such variation is thus positively assessed.

Applicability to masonry, AAC or concrete walls

The scope of AS 1530.4:2014, clause 10.12.2 (c), allows the application of test results obtained in plasterboard-lined partitions to be applied to solid or hollow masonry or normal weight concrete walls of the same or greater thickness and of equivalent FRL.

FRLs in section 7.0 for 100 mm thick flexible walls with double layer 50 mm thick boards, can be used in 75 mm thick flexible and rigid walls with a maximum aperture of 1200 mm high × 900 mm wide, limited to - /60/60 unless specified otherwise in section 7.0. The boards must be positioned centrally within the wall, and any exposed mineral fibres must be coated with FR Coating.

As the seal depth therefore maintains at least 25 mm deep as tested, it is hence considered the performance of the penetrations will not be detrimentally affected if installed in bare walls that are less than 100 mm thick.

As the proposed rigid wall thickness is less than the tested frame wall system, they are required to be tested or otherwise assessed by others to have equal or better established FRL of the separating wall element. The proposed construction includes such variations and is thus positively assessed.

Reducing floor thickness to 100 mm

Applicability of FRLs given to 150 mm thick floors to thinner concrete slabs of minimum thickness 100 mm is permissible. However, the insulation performance of the system will be governed by the concrete slab thickness as stated in AS/NZS 3600:2018. The overall FRL of the system will be governed by the FRL extracted from AS/NZS 3600:2018 as shown below:

Table 60 Maximum fire resistance for given slab thicknesses

Effective slab thickness	Maximum fire resistance
100mm	90 minutes
120 mm	120 minutes
150 mm	180 minutes
175 mm	240 minutes

Applicability in both walls and floors

- + It was confirmed that the tested Polyethylene pipes were PE100 which as confirmed by report sponsor and pipe manufacturer is similar to HDPE pipes. Therefore, the FRLs shown for PE pipes in section 6 are applicable to HDPE pipes.
- + Test results for cables remain valid if the diameter of a single cable is reduced and/or number of cables in a bunch is reduced provided that overall diameter of the bunch of any individual cable is not greater than tested.
- + The test results obtained with standard configuration covers all types of insulated cables with copper or aluminium conductors, fibre optic cables and bundled communication cables, except hollow cables.
- + Results obtained from tests where the supports pass through the seal are applicable to those situations where the support is not continued but not vice versa
- + The test results obtained using standard configuration for cable penetration systems are valid for:
 - All type of steel cable trays and ladders
 - Any penetration size equal or smaller than that tested, provided the total amount of cross sections of the cables (core and insulation) does not exceed 60% of the penetration.
- + Support of services in walls and floors must be maintained as per AS 1530.4:2014 and AS 4072.1:2005 requirements.

Applicability of results to uninsulated pipes

It is proposed that the integrity rating achieved for insulated pipes can be applied to uninsulated pipes.

As per AS 1530.4:2014, a specimen is deemed to have failed the integrity criterion in when any of the following occur:

- + Sustained flaming for 10 seconds
- + A gap form that allows the passage of hot gases to the unexposed face and ignite the cotton pad when applied for up to 30 seconds
- + A gap forms that allows the penetration of a 25 mm gap gauge anywhere on the specimen
- + A gap forms that allows a 6 mm × 150 mm gap gauge to penetrate the specimen (anywhere on the specimen).

Upon closer inspection of the tested specimens, it was observed that the above systems were able to maintain integrity performance for the duration of the test with no significant observations on cracks or gaps forming around the penetration on the unexposed side that could have promoted an integrity failure. Moreover, it is acknowledged that the insulation provided on the metallic and composite pipes is for insulation rating purposes only as it was interrupted and did not continue through the penetration.

Therefore, it is established that the insulation around the pipes has no bearing on the fire integrity rating of the system and assuming that the insulation rating is zero, removing the insulation on the pipe systems will not cause any detrimental effect to the integrity rating of the pipe system. This variation can therefore be positively assessed.

Applicability of FRLs to services in core-drilled holes

It is proposed that the fire performance achieved by services penetrating FR boards and protected with FR Pipe Wraps can be extended to services passing through core-drilled holes in rigid walls and floors. The maximum annular gap must be 30 mm and the services are to be protected with FR Pipe Wraps on both the exposed and unexposed side in walls and the exposed side in floors. The rest of the annular gap is to be filled with FR Acrylic sealant to the full depth in walls and to the depth of 15 mm in floors backed with 25 mm deep stone wool backing (minimum density 33 kg/m³).

To achieve the same FRLs, the number and size of intumescent layers of the FR Pipe Wraps used in core-drilled holes must be the same as when FR Pipe Wrap is used in conjunction with FR Boards for the particular services considered as given in section 6. Wall and floor elements are required to be otherwise tested or assessed by others for the required fire resistance period. In cases where the FRL of the wall or floor is less than that of the penetration, the FRL will be derated accordingly.

With the FR Pipe Wrap installed around the service, in a fire event the pipe wrap is expected to expand and fill the annular gap thus maintaining the integrity performance of the penetration. Any remaining gaps will be sealed by the FR Acrylic sealant.

8.0 Validity

Jensen Hughes does not endorse the tested or assessed products and systems in any way. The conclusions of this assessment may be used to directly assess fire resistance, but it should be recognised that a single test method will not provide a full assessment of fire resistance under all conditions.

Due to the nature of fire testing and the consequent difficulty in quantifying the uncertainty of measurement, it is not possible to provide a stated degree of accuracy. The inherent variability in test procedures, materials and methods of construction, and installation may lead to variations in performance between elements of similar construction.

This assessment is based on test data, information and experience available at the time of preparation. If contradictory evidence becomes available to the assessing authority, the assessment will be unconditionally withdrawn and the report sponsor will be notified in writing. Similarly, the assessment should be re-evaluated, if the assessed construction is subsequently tested since actual test data is deemed to take precedence.

The sponsor is responsible for formally notifying Jensen Hughes of any additional testing performed on their product/system. This obligation applies regardless of where the test was conducted, the results of the test, or whether it was initially considered part of Jensen Hughes' ongoing assessment. The primary goal of this notification is to allow Jensen Hughes to review the changes and determine whether they require re-evaluation or re-testing to determine whether the changes have affected the product's performance. It is important that the client promptly notify Jensen Hughes if any such changes are implemented.

The procedures for the conduct of tests and the assessment of test results are subject to constant review and improvement. The sponsor is therefore recommended that this report be reviewed on, or before, the stated expiry date.

This assessment represents our opinion about the performance of the proposed systems that is expected to be demonstrated when subjected to test conditions in accordance with AS 1530.4:2014, based on the evidence referred to in this report.

This assessment is provided to Firestop Centre Limited for their own specific purposes. This report may be used as evidence of suitability in accordance with the requirements of the relevant National Construction Code. Building certifiers and other third parties must determine the suitability of the systems described in this report for a specific installation.

Appendix A Drawings and additional information

Table 61 Details of figures

Drawing title	Dwg no	Date	Drawn by
All drawings of construction details and graphical representation of intermediate service diameters and wall thicknesses as provided in section 6.	-	-	Extracted from the European Technical Assessment ETA-21/0047 of 2021/01/01 provided by Polyseam Ltd.

Appendix B Summary of supporting test data

B.1 Test report – WF423530

Table 62 Information about test report

Item	Information about test report
Report sponsor	Polyseam Ltd, St Andrews Road, Huddersfield, West Yorkshire, HD1, 6SB, UK.
Test laboratory	Warringtonfire, Chiltern House, Stocking Lane, High Wycombe, HP14, 4ND, UK.
Test date	The fire resistance test was completed on 29 January 2020.
Test standards	The test was done in accordance with BS EN 1363-1:2012 and BS EN 1366-3:2009.
Variation to test standards	None.
General description of tested specimen	<p>The supporting construction comprised of a 3 m wide × 3 m high steel stud / plasterboard clad partition, built in accordance with BS EN 1366-3:2009.</p> <p>The partition framing comprised of 50 mm × 25 mm high steel c-section studs fitted at nominally 600 mm centres and 52 mm wide × 35 mm high steel U-channel head and base track, with 50 mm thick, 33 kg/m³ density mineral wool insulation friction fitted between the studs. The framing was clad on both faces with 1 layer of 12.5 mm thick Type F plasterboard.</p> <p>The services referenced in this assessment report are A1-A5 and A7. All pipes and cables measured 1200 mm long with a minimum of 500 mm protruding from the exposed face. The mineral wool insulation within the partition wall was removed for 100 mm surrounding all apertures.</p> <p>The fire stopping products used for the test were 50 mm thick Protecta FR Board 1-S, Protecta FR Transits, Mineral Bio Wool, Protecta FR Wrap, Protecta FR Coating, Protecta FR Acrylic, Protecta FR Collars.</p>
Instrumentation	The test report states that the instrumentation was in accordance with BS EN 1363-1:2012 and BS EN 1366-3:2009.

The test specimen achieved the following results – see Table 63.

Table 63 Results summary for this test report

Specimen	Aperture	Seal description	Service insulation	FRL
A1 – Ladder Tray 1 – steel 300 mm wide with 1 of Type D1 cable, 2 of Type E cable, 1 of Type D2 cable.	1200 mm × 1200 mm	2 FR Boards 50 mm 1-S, board edges sealed to the aperture with FR Coating. All batts sealed to the service with FR Acrylic.	None	-/60/30
A2 – Steel pipe with an outer diameter of 114 mm and pipe wall thickness of 2 mm.	Ø114 mm	Pipe capping: C/U 2 FR Boards 50 mm 1-S, board edges sealed to the aperture with FR Acrylic. All batts sealed to the service with FR Acrylic.	Protecta FR-1 service coating on both faces all the way to the seal, nominal 200 mm × 750 µm WFT/500 µmDFT	-/60/15
A3 – Geberit Mepla Alupex pipe with an outer diameter of 75 mm and a pipe wall thickness of 4.6 mm	Ø75 mm	Pipe capping: C/C 2 FR Boards 50 mm 1-S, board edges sealed to the aperture with FR Acrylic. All batts sealed to the service with FR Acrylic.	500 mm long × 20 mm thick stonewool insulation 80 kg/m ³ localised interrupted insulation 500 mm on each face.	-/60/60

Specimen	Aperture	Seal description	Service insulation	FRL
A4 - Copper pipe with an outer diameter of 54 mm and a pipe wall thickness of 1.2 mm	Ø87.2 mm	Pipe capping: C/C 2 FR Boards 50 mm 1-S, board edges sealed to the aperture with FR Acrylic. All batts sealed to the service with 2 layers of Protecta FR wrap (intumescent size: 50 mm wide and 1.8 mm thick)	Armacell Ace elastometric foam 13 mm thick	-/60/60
A5 - Steel pipe with an outer diameter of 22 mm and a pipe wall thickness of 2.0 mm	Ø22 mm	Pipe capping: C/U 2 FR Boards 50 mm 1-S, board edges sealed to the aperture with FR Acrylic. All batts sealed to the service with FR Acrylic.	None	-/60/60
A7 – PVC pipe with an outer diameter of 32 mm and a pipe wall thickness of 1.8 mm	Ø32 mm	Pipe capping: U/C 2 FR Boards 50 mm 1-S, board edges sealed to the aperture with FR Acrylic. All batts sealed to the service with FR Acrylic.	None	-/60/60

B.2 Test report – WF 427934

Table 64 Information about test report

Item	Information about test report
Report sponsor	Polyseam Ltd, St Andrews Road, Huddersfield, West Yorkshire, HD1, 6SB, UK.
Test laboratory	Warringtonfire, Chiltern House, Stocking Lane, High Wycombe, HP14, 4ND, UK.
Test date	The fire resistance test was completed on 14 April 2020.
Test standards	The test was done in accordance with BS EN 1363-1:2012 and BS EN 1366-3:2009.
Variation to test standards	None.
General description of tested specimen	<p>The supporting construction comprised of a 3 m wide × 3 m high steel stud / plasterboard clad partition, built in accordance with BS EN 1366-3:2009.</p> <p>The partition framing comprised of 50 mm × 25 mm high steel c-section studs fitted at nominally 600 mm centres and 52 mm wide × 35 mm high steel U-channel head and base track, with 50 mm thick, 33 kg/m³ density mineral wool insulation friction fitted between the studs. The framing was clad on both faces with 2 layers of 12.5 mm thick Type F plasterboard.</p> <p>The services referenced in this assessment report are B2, B3, C1-C3 and G1-G3. All pipes and cables measured 1200 mm long with a minimum of 500 mm protruding from the exposed face. The mineral wool insulation within the partition wall was removed for 100 mm surrounding all apertures.</p>
Instrumentation	The test report states that the instrumentation was in accordance with BS EN 1363-1:2012 and BS EN 1366-3:2009.

The test specimen achieved the following results – see Table 65.

Table 65 Results summary for this test report

Specimen	Aperture	Seal description	Service insulation	FRL
B1 – Blue Power Multilayer pipe TR01-PP pipe with an outer diameter of 160 mm and a pipe wall thickness of 4.9 mm.	Ø182 mm	Pipe capping: U/C 2 FR Boards 50 mm 1-S, board edges sealed to the service with 6 layers of Protecta FR wrap (intumescent size: 50 mm wide and 1.8 mm thick)	None	-/90/90
B2 – Uponer Decibel PP-MD pipe with an outer diameter of 110 mm and a pipe wall thickness of 3.8 mm.	Ø118 mm	Pipe capping: U/C 2 FR Boards 50 mm 1-S, board edges sealed to the service with 2 layers of Protecta FR wrap (intumescent size: 50 mm wide and 1.8 mm thick)	None	-/90/90
B3 – Uponer Decibel MD pipe with an outer diameter of 50 mm and a pipe wall thickness of 2.0 mm.	Ø57.2 mm	Pipe capping: U/U 2 FR Boards 50 mm 1-S, board edges sealed to the service with 2 layers of Protecta FR wrap (intumescent size: 50 mm wide and 1.8 mm thick)	None	-/90/90
C1 – Mix bundle of PVC, PE and PP with nominal bundle diameter of 110 mm.	Ø118 mm	Pipe capping: U/C 2 FR Boards 50 mm 1-S, board edges sealed to the service with 2 layers of Protecta FR wrap (intumescent size: 50 mm wide and 1.8 mm thick)	None	-/90/90

Specimen	Aperture	Seal description	Service insulation	FRL
C2 – Mix bundle of PVC, PE, PP, F type cables with nominal bundle diameter of 110 mm.	Ø118 mm	Pipe capping: U/C 2 FR Boards 50 mm 1-S, board edges sealed to the service with 2 layers of Protecta FR wrap (intumescent size: 50 mm wide and 1.8 mm thick)	None	-/90/90
C3 – Uponer MLCP Pre insulated pipe with overall size 51 mm diameter and pipe size is 25 mm (Wall thickness: 25 mm)	Ø58 mm	Pipe capping: C/C 2 FR Boards 50 mm 1-S, board edges sealed to the service with 2 layers of Protecta FR wrap (intumescent size: 50 mm wide and 1.8 mm thick)	Pre-installed 13 mm polyethylene foam with plastic sheaving	-/90/60
G1 – Steel pipe with outer diameter 273 mm and pipe wall thickness 6.35 mm	Ø476.6 mm	Pipe capping: C/U 2 FR Boards 50 mm 1-S, board edges sealed to the service with 1 layers of Protecta FR wrap (intumescent size: 50 mm wide and 1.8 mm thick)	100 mm thick Phenolic foam - CS	-/90/90
G2 – Steel pipe with outer diameter 273 mm and pipe wall thickness 6.35 mm	Ø326.6 mm	Pipe capping: C/U 2 FR Boards 50 mm 1-S, board edges sealed to the service with 1 layer of Protecta FR wrap (intumescent size: 50 mm wide and 1.8 mm thick)	25 mm thick Phenolic foam - CS	-/90/90
G3 – Steel pipe with outer diameter 16 mm and pipe wall thickness 1.0 mm	Ø49.6 mm	Pipe capping: C/U 2 FR Boards 50 mm 1-S, board edges sealed to the service with 1 layer of Protecta FR wrap (intumescent size: 50 mm wide and 1.8 mm thick)	15 mm thick Phenolic foam - CS	-/90/90

B.3 Test report – WF 419763

Table 66 Information about test report

Item	Information about test report
Report sponsor	Polyseam Ltd, St Andrews Road, Huddersfield, West Yorkshire, HD1, 6SB, UK.
Test laboratory	Warringtonfire, Chiltern House, Stocking Lane, High Wycombe, HP14, 4ND, UK.
Test date	The fire resistance test was completed on 19 November 2019.
Test standards	The test was done in accordance with BS EN 1363-1:2012 and BS EN 1366-3:2009.
Variation to test standards	None.
General description of tested specimen	<p>The supporting construction comprised of a 3 m wide × 3 m high steel stud / plasterboard clad partition, built in accordance with BS EN 1366-3:2009.</p> <p>The partition framing comprised of 50 mm × 25 mm high steel c-section studs fitted at nominally 600 mm centres and 52 mm wide × 35 mm high steel U-channel head and base track, with 50 mm thick, 33 kg/m³ density mineral wool insulation friction fitted between the studs. The framing was clad on both faces with 2 layers of 12.5 mm thick Type F plasterboard.</p> <p>The services referenced in this assessment report are B1-B3 and M1-M3. All pipes and cables measured 1200 mm long with a minimum of 500 mm protruding from the exposed face. The mineral wool insulation within the partition wall was removed for 100 mm surrounding all apertures.</p>
Instrumentation	The test report states that the instrumentation was in accordance with BS EN 1363-1:2012 and BS EN 1366-3:2009.

The test specimen achieved the following results – see Table 67.

Table 67 Results summary for this test report

Specimen	Aperture	Seal description	Service insulation	FRL
B1 – PE pipe with outer diameter of 160 mm and pipe wall thickness of 4.9 mm.	Ø181.6 mm	Pipe capping: U/C 2 FR Boards 50 mm 1-S, board edges sealed to the service with 6 layers of Protecta FR wrap (intumescent size: 50 mm wide and 1.8 mm thick)	None	-/90/60
B2 – PVC pipe with outer diameter of 160 mm and pipe wall thickness of 4.0 mm.	Ø181.6 mm	Pipe capping: U/C 2 FR Boards 50 mm 1-S, board edges sealed to the service with 6 layers of Protecta FR wrap (intumescent size: 50 mm wide and 1.8 mm thick)	None	-/90/60
B3 – PP pipe with outer diameter of 160 mm and pipe wall thickness of 4.9 mm.	Ø181.6 mm	Pipe capping: U/C 2 FR Boards 50 mm 1-S, board edges sealed to the service with 6 layers of Protecta FR wrap (intumescent size: 50 mm wide and 1.8 mm thick)	None	-/90/60
M1 – Copper pipe with outer diameter 15 mm and pipe wall thickness 0.7 mm	Ø55 mm	Pipe capping: C/C 2 FR Boards 50 mm 1-S, board edges sealed to the service with Protecta FR Acrylic	20 mm thick Climpipe insulation - CS	-/60/60
M2 – Copper pipe with outer diameter 54 mm and pipe wall thickness 1.2 mm	Ø94 mm	Pipe capping: C/C 2 FR Boards 50 mm 1-S, board edges sealed to the service with Protecta FR Acrylic	20 mm thick Climpipe insulation - CS	-/60/30

Specimen	Aperture	Seal description	Service insulation	FRL
M3 – Copper pipe with outer diameter 54 mm and pipe wall thickness 1.2 mm	Ø134 mm	Pipe capping: C/C 2 FR Boards 50 mm 1-S, board edges sealed to the service with Protecta FR Acrylic	40 mm thick Climpipe insulation - CS	-/60/60

B.4 Test report – WF 398928 REVISION A

Table 68 Information about test report

Item	Information about test report
Report sponsor	Polyseam Ltd, St Andrews Road, Huddersfield, West Yorkshire, HD1, 6SB, UK.
Test laboratory	Warringtonfire, Chiltern House, Stocking Lane, High Wycombe, HP14, 4ND, UK.
Test date	The fire resistance test was completed on 6 August 2018.
Test standards	The test was done in accordance with BS EN 1363-1:2012 and BS EN 1366-3:2009.
Variation to test standards	None.
General description of tested specimen	<p>The supporting construction comprised of a 3 m wide × 3 m high steel stud / plasterboard clad partition, built in accordance with BS EN 1366-3:2009.</p> <p>The partition framing comprised of 50 mm × 25 mm high steel c-section studs fitted at nominally 600 mm centres and 52 mm wide × 35 mm high steel U-channel head and base track, with 50 mm thick, 35 kg/m³ density mineral wool insulation friction fitted between the studs. The framing was clad on both faces with 2 layers of 12.5 mm thick Type F plasterboard.</p> <p>The service referenced in this assessment report is D. All pipes and cables measured 1200 mm long with a minimum of 500 mm protruding from the exposed face. The mineral wool insulation within the partition wall was removed for 100 mm surrounding all apertures. The aperture was unlined.</p>
Instrumentation	The test report states that the instrumentation was in accordance with BS EN 1363-1:2012 and BS EN 1366-3:2009.

The test specimen achieved the following results – see Table 69.

Table 69 Results summary for this test report

Specimen	Aperture	Seal description	Service insulation	FRL
D – PP pipe with outer diameter of 315 mm and pipe wall thickness of 28.6 mm.	Aperture through fire seal batt: Ø351 mm Aperture size for batts: 500 mm high × 500 mm wide	Pipe capping: C/C 2 FR Boards 50 mm 1-S (160 kg/m ³), board edges sealed to the service with 10 layers of Protecta FR wrap (intumescent size: 50 mm wide and 1.8 mm thick)	None	-/60/60

B.5 Test report – WF 398517 REVISION B

Table 70 Information about test report

Item	Information about test report
Report sponsor	Polyseam Ltd, St Andrews Road, Huddersfield, West Yorkshire, HD1, 6SB, UK.
Test laboratory	Warringtonfire, Chiltern House, Stocking Lane, High Wycombe, HP14, 4ND, UK.
Test date	The fire resistance test was completed on 19 April 2018.
Test standards	The test was done in accordance with BS EN 1363-1:2012 and BS EN 1366-3:2009.
Variation to test standards	None.
General description of tested specimen	<p>The supporting construction comprised of a 3 m wide × 3 m high steel stud / plasterboard clad partition, built in accordance with BS EN 1366-3:2009.</p> <p>The partition framing comprised of 50 mm × 25 mm high steel c-section studs fitted at nominally 600 mm centres and 52 mm wide × 35 mm high steel U-channel head and base track, with 50 mm thick, 35 kg/m³ density mineral wool insulation friction fitted between the studs. The framing was clad on both faces with 2 layers of 12.5 mm thick Type F plasterboard.</p> <p>The service referenced in this assessment report is J. All pipes and cables measured 1200 mm long with a minimum of 500 mm protruding from the exposed face. The mineral wool insulation within the partition wall was removed for 100 mm surrounding all apertures. The aperture was unlined.</p>
Instrumentation	The test report states that the instrumentation was in accordance with BS EN 1363-1:2012 and BS EN 1366-3:2009.

The test specimen achieved the following results – see Table 71.

Table 71 Results summary for this test report

Specimen	Aperture	Seal description	Service insulation	FRL
J – PE pipe with outer diameter of 400 mm and pipe wall thickness of 23.7 mm.	Ø457.6 mm	Pipe capping: C/C 2 FR Boards 50 mm 1-S (160 kg/m ³), board edges sealed to the service with 16 layers of Protecta FR wrap (intumescent size: 50 mm wide and 1.8 mm thick)	None	-/60/60

B.6 Test report – WF 419764

Table 72 Information about test report

Item	Information about test report
Report sponsor	Polyseam Ltd, St Andrews Road, Huddersfield, West Yorkshire, HD1, 6SB, UK.
Test laboratory	Warringtonfire, Chiltern House, Stocking Lane, High Wycombe, HP14, 4ND, UK.
Test date	The fire resistance test was completed on 12 December 2019.
Test standards	The test was done in accordance with BS EN 1363-1:2012 and BS EN 1366-3:2009.
Variation to test standards	None.
General description of tested specimen	The supporting construction comprised of a 3 m wide × 3 m × 150 mm thick blockwork wall. The services referenced in this assessment report are B1-B3, D1-D3, E1-E2, F1-F3 and J. All pipes and cables measured 1200 mm long with a minimum of 500 mm protruding from the exposed face.
Instrumentation	The test report states that the instrumentation was in accordance with BS EN 1363-1:2012 and BS EN 1366-3:2009.

The test specimen achieved the following results – see Table 73.

Table 73 Results summary for this test report

Specimen	Aperture	Seal description	Service insulation	FRL
B1 – PVC pipe with outer diameter of 200 mm and pipe wall thickness of 11.9 mm.	Ø221.6 mm	Pipe capping: C/C 2 FR Boards 60 mm 2-S, board edges sealed to the service with 6 layers of Protecta FR wrap (intumescent size: 75 mm wide and 1.8 mm thick)	None	-/180/180
B2 – PE pipe with outer diameter of 200 mm and pipe wall thickness of 18.2 mm.	Ø221.6 mm	Pipe capping: C/C 2 FR Boards 60 mm 2-S, board edges sealed to the service with 6 layers of Protecta FR wrap (intumescent size: 75 mm wide and 1.8 mm thick)	None	-/180/180
B3 – PP pipe with outer diameter of 200 mm and pipe wall thickness of 18.2 mm.	Ø221.6 mm	Pipe capping: C/C 2 FR Boards 60 mm 2-S, board edges sealed to the service with 6 layers of Protecta FR wrap (intumescent size: 75 mm wide and 1.8 mm thick)	None	-/180/180
D1 – PVC pipe with outer diameter of 32 mm and pipe wall thickness of 1.6 mm.	Ø32 mm	Pipe capping: U/C 2 FR Boards 60 mm 2-S, board edges sealed to the service with Protecta FR Acrylic	None	-/240/240

Specimen	Aperture	Seal description	Service insulation	FRL
D2 – PVC pipe with outer diameter of 32 mm and pipe wall thickness of 2.4 mm.	Ø32 mm	Pipe capping: U/C 2 FR Boards 60 mm 2-S, board edges sealed to the service with Protecta FR Acrylic	None	-/240/240
D1 – PVC pipe with outer diameter of 20 mm and pipe wall thickness of 1.0 mm.	Ø20 mm	Pipe capping: U/C 2 FR Boards 60 mm 2-S, board edges sealed to the service with Protecta FR Acrylic	None	-/240/240
E1 – PE pipe with outer diameter of 400 mm and pipe wall thickness of 36.3 mm.	Ø457.6 mm	Pipe capping: C/C 2 FR Boards 60 mm 2-S, board edges sealed to the service with 16 layers of Protecta FR wrap (intumescent size: 75 mm wide and 1.8 mm thick)	None	-/120/120
E2 – PE pipe with outer diameter of 315 mm and pipe wall thickness of 28.6 mm.	Ø351 mm	Pipe capping: C/C 2 FR Boards 60 mm 2-S, board edges sealed to the service with 10 layers of Protecta FR wrap (intumescent size: 75 mm wide and 1.8 mm thick)	None	-/180/120
F1 – PVC pipe with outer diameter of 200 mm and pipe wall thickness of 4.9 mm.	Ø226.1 mm	Pipe capping: C/C 2 FR Boards 60 mm 2-S, board edges sealed to the service with 6 layers of Protecta FR wrap (intumescent size: 75 mm wide and 1.8 mm thick)	None	-/240/240
F2 – PE pipe with outer diameter of 200 mm and pipe wall thickness of 4.9 mm.	Ø226.1 mm	Pipe capping: C/C 2 FR Boards 60 mm 2-S, board edges sealed to the service with 6 layers of Protecta FR wrap (intumescent size: 75 mm wide and 1.8 mm thick)	None	-/240/240
F2 – PP pipe with outer diameter of 200 mm and pipe wall thickness of 4.9 mm.	Ø226.1 mm	Pipe capping: C/C 2 FR Boards 60 mm 2-S, board edges sealed to the service with 6 layers of Protecta FR wrap (intumescent size: 75 mm wide and 1.8 mm thick)	None	-/240/240

Specimen	Aperture	Seal description	Service insulation	FRL
<p>J – PP pipe with 16 mm diameter and 1.8 mm wall thickness</p> <p>PP pipe with 32 mm diameter and 2.0 mm wall thickness</p> <p>PP pipe with 32 mm diameter and 4.4 mm wall thickness</p> <p>PE pipe with 20 mm diameter and 2.2 mm wall thickness</p> <p>PE pipe with 32 mm diameter and 2.0 mm wall thickness</p> <p>PE pipe with 32 mm diameter and 4.4 mm wall thickness</p> <p>PVC pipe with 20 mm diameter and 1.0 mm wall thickness</p> <p>PVC pipe with 32 mm diameter and 1.6 mm wall thickness</p> <p>PVC pipe with 32 mm diameter and 2.4 mm wall thickness</p>	<p>Ø107 mm in batts fitted in an aperture of 230 mm × 230 mm × 150 mm</p>	<p>PP and PE pipes are C/U and PVC pipes are U/C</p> <p>60 mm thick Protecta FR board 60 2-S sealed to the separating element with Protecta FR Acrylic. Protecta FR Wrap 2 layers of 50 mm wide × 1.8 mm thick fitted both sides</p>	<p>None</p>	<p>-/240/240</p>

B.7 Test report – WF 411108

Table 74 Information about test report

Item	Information about test report
Report sponsor	Polyseam Ltd, St Andrews Road, Huddersfield, West Yorkshire, HD1, 6SB, UK.
Test laboratory	Warringtonfire, Chiltern House, Stocking Lane, High Wycombe, HP14, 4ND, UK.
Test date	The fire resistance test was completed on 1 March 2019.
Test standards	The test was done in accordance with BS EN 1363-1:2012 and BS EN 1366-3:2009.
Variation to test standards	None.
General description of tested specimen	<p>The supporting construction comprised of a 3 m wide × 3 m high steel stud / plasterboard clad partition, built in accordance with BS EN 1366-3:2009.</p> <p>The partition framing comprised of 50 mm × 25 mm high steel c-section studs fitted at nominally 600 mm centres and 52 mm wide × 35 mm high steel U-channel head and base track, with 50 mm thick, 33 kg/m³ density mineral wool insulation friction fitted between the studs. The framing was clad on both faces with 2 layers of 12.5 mm thick Type F plasterboard.</p> <p>The service referenced in this assessment report is D. All pipes and cables measured 1200 mm long with a minimum of 500 mm protruding from the exposed face. The mineral wool insulation within the partition wall was removed for 100 mm surrounding all apertures. The aperture was unlined.</p>
Instrumentation	The test report states that the instrumentation was in accordance with BS EN 1363-1:2012 and BS EN 1366-3:2009.

The test specimen achieved the following results – see Table 75.

Table 75 Results summary for this test report

Specimen	Aperture	Seal description	Service insulation	FRL
A2 – Copper pipe with outer diameter of 15 mm and pipe wall thickness of 0.7 mm.	Ø55 mm	Pipe capping: C/C 1 FR Board 50 mm 2-S, Protecta FR Acrylic sealing pipe to batt on both faces	20 mm thick Isover CLIMPIPE section Alu2 - CS	-/60/30
A4 – Gerberit Mepla pipe with outer diameter of 16 mm and pipe wall thickness of 2.25 mm.	Ø56 mm	Pipe capping: C/C 1 FR Board 50 mm 2-S, Protecta FR Acrylic sealing pipe to batt on both faces	20 mm thick Isover CLIMPIPE section Alu2 - CS	-/60/30
B1 – Copper pipe with outer diameter of 54 mm and pipe wall thickness of 1.2 mm.	Ø134 mm	Pipe capping: C/C 1 FR Board 50 mm 2-S, Protecta FR Acrylic sealing pipe to batt on both faces	40 mm thick Isover CLIMPIPE section Alu2 - CS	-/60/30
B2 – Copper pipe with outer diameter of 15 mm and pipe wall thickness of 0.7 mm.	Ø15 mm	Pipe capping: C/C 1 FR Board 50 mm 2-S, Protecta FR Acrylic sealing pipe to batt on both faces	20 mm thick Isover CLIMPIPE section Alu2 - CS	-/60/30

Specimen	Aperture	Seal description	Service insulation	FRL
B3 – Copper pipe with outer diameter of 15 mm and pipe wall thickness of 0.7 mm.	Ø33 mm	Pipe capping: C/C 1 FR Board 50 mm 2-S, Protecta FR collar Ø32 on both faces, fixed to the batt with 40 mm long pigtail screws (intumescent size 50 mm deep × 3 mm thick)	9 mm thick Kaiflex ST elastomeric foam - CS	-/60/30
B4 – Copper pipe with outer diameter of 54 mm and pipe wall thickness of 1.2 mm.	Ø94 mm	Pipe capping: C/C 1 FR Board 50 mm 2-S, Protecta FR Acrylic sealing pipe to batt on both faces	20 mm thick Isover CLIMPIPE section Alu2 - CS	-/60/30
B5 – Copper pipe with outer diameter of 54 mm and pipe wall thickness of 1.2 mm.	Ø72 mm	Pipe capping: C/C 1 FR Board 50 mm 2-S, Protecta FR collar Ø75 on both faces, fixed to the batt with 40 mm long pigtail screws (intumescent size 50 mm deep × 4.2 mm thick)	9 mm thick Kaiflex ST elastomeric foam - CS	-/60/30
C1 – Gerberit Mepla pipe with outer diameter of 75 mm and pipe wall thickness of 4.6 mm.	Ø125 mm	Pipe capping: C/C 1 FR Board 50 mm 2-S, Protecta FR acrylic sealing pipe to batt on both faces	20 mm thick CLIMPIPE section Alu2 - CS	-/60/60
C2 – Gerberit Mepla pipe with outer diameter of 75 mm and pipe wall thickness of 4.6 mm.	Ø125 mm	Pipe capping: C/C 1 FR Board 50 mm 2-S, Protecta FR collar Ø125 on both faces, fixed to the batt with 40 mm long pigtail screws (intumescent size 60 mm deep × 9 mm thick)	25 mm thick Armaflex ACE elastomeric foam - CS	-/60/60
C3 – Copper pipe with outer diameter of 54 mm and pipe wall thickness of 1.2 mm.	Ø104 mm	Pipe capping: C/C 1 FR Board 50 mm 2-S, Protecta FR collar Ø110 on both faces, fixed to the batt with 40 mm long pigtail screws (intumescent size 60 mm deep × 6 mm thick)	25 mm thick Armaflex ACE elastomeric foam - CS	-/60/30
C4 – Gerberit Mepla pipe with outer diameter of 75 mm and pipe wall thickness of 4.6 mm.	Ø93 mm	Pipe capping: C/C 1 FR Board 50 mm 2-S, Protecta FR collar Ø110 on both faces, fixed to the batt with 40 mm long pigtail screws (intumescent size 50 mm deep × 6 mm thick)	9 mm thick Kaiflex ST elastomeric foam - CS	-/60/30

Specimen	Aperture	Seal description	Service insulation	FRL
D1 – PP pipe with outer diameter of 160 mm and pipe wall thickness of 4.9 mm.	Ø160 mm	Pipe capping: C/C 1 FR Board 50 mm 2-S, Protecta FR collar Ø160 on both faces, fixed to the batt with 40 mm long pigtail screws (intumescent size 60 mm deep × 15 mm thick)	None	-/60/60
D2 – PP pipe with outer diameter of 110 mm and pipe wall thickness of 2.7 mm.	Ø110 mm	Pipe capping: C/C 1 FR Board 50 mm 2-S, Protecta FR collar Ø110 on both faces, fixed to the batt with 40 mm long pigtail screws (intumescent size 50 mm deep × 6 mm thick)	None	-/60/60
D3 – Copper pipe with outer diameter of 54 mm and pipe wall thickness of 1.2 mm.	Ø54 mm	Pipe capping: C/C 1 FR Board 50 mm 2-S, Protecta FR acrylic sealing pipe to batt on both faces	20 mm thick Isover CLIMPIPE section Alu2 localised interrupted 500 mm each face	-/60/30
D4 – PP pipe with outer diameter of 160 mm and pipe wall thickness of 9.1 mm.	Ø160 mm	Pipe capping: C/C 1 FR Board 50 mm 2-S, Protecta FR collar Ø160 on both faces, fixed to the batt with 40 mm long pigtail screws (intumescent size 60 mm deep × 15 mm thick)	None	-/60/60
E1 – PP pipe with outer diameter of 160 mm and pipe wall thickness of 4.9 mm.	Ø296 mm	Pipe capping: C/C 2 FR Boards 50 mm 1-S, 10 layers of Protecta FR wrap fitted on both sides (50 mm wide × 1.8 mm thick each layer)	50 mm thick Kaiflex ST elastomeric foam - CS	-/60/60
E2 – PE pipe with outer diameter of 160 mm and pipe wall thickness of 9.5 mm.	Ø296 mm	Pipe capping: C/C 2 FR Boards 50 mm 1-S, 10 layers of Protecta FR wrap fitted on both sides (50 mm wide × 1.8 mm thick each layer)	50 mm thick Kaiflex ST elastomeric foam - CS	-/60/60
E3 – PE pipe with outer diameter of 160 mm and pipe wall thickness of 4.9 mm.	Ø296 mm	Pipe capping: C/C 2 FR Boards 50 mm 1-S, 10 layers of Protecta FR wrap fitted on both sides (50 mm wide × 1.8 mm thick each layer)	50 mm thick Kaiflex ST elastomeric foam - CS	-/60/60

Specimen	Aperture	Seal description	Service insulation	FRL
E4 – PP pipe with outer diameter of 160 mm and pipe wall thickness of 9.1 mm.	Ø296 mm	Pipe capping: C/C 2 FR Boards 50 mm 1-S, 10 layers of Protecta FR wrap fitted on both sides (50 mm wide × 1.8 mm thick each layer)	50 mm thick Kaiflex ST elastomeric foam - CS	-/60/60
F1 – PVC-u pipe with outer diameter of 160 mm and pipe wall thickness of 4.0 mm.	Ø160 mm	Pipe capping: C/C 1 FR Board 50 mm 2- S, Protecta FR collar Ø160 on both faces, fixed to the batt with 40 mm long pigtail screws (intumescent size 60 mm deep × 15 mm thick)	None	-/60/60
F3 – Gerberit Mepla pipe with outer diameter of 16 mm and pipe wall thickness of 2.25 mm.	Ø34 mm	Pipe capping: C/C 1 FR Board 50 mm 2- S, Protecta FR collar Ø40 on both faces, fixed to the batt with 40 mm long pigtail screws (intumescent size 50 mm deep × 3 mm thick)	9 mm thick Kaiflex ST elastomeric foam - CS	-/60/60
F4 – PVC-u pipe with outer diameter of 160 mm and pipe wall thickness of 9.5 mm.	Ø160 mm	Pipe capping: C/C 1 FR Board 50 mm 2- S, Protecta FR collar Ø160 on both faces, fixed to the batt with 40 mm long pigtail screws (intumescent size 60 mm deep × 15 mm thick)	None	-/60/60
G1 – PE-HD pipe with outer diameter of 160 mm and pipe wall thickness of 4.9 mm.	Ø160 mm	Pipe capping: C/C 1 FR Board 50 mm 2- S, Protecta FR collar Ø160 on both faces, fixed to the batt with 40 mm long pigtail screws (intumescent size 60 mm deep × 15 mm thick)	None	-/60/60
G2 – PP pipe with outer diameter of 50 mm and pipe wall thickness of 1.8 mm.	Ø50 mm	Pipe capping: C/C 1 FR Board 50 mm 2- S, Protecta FR collar Ø55 on both faces, fixed to the batt with 40 mm long pigtail screws (intumescent size 50 mm deep × 3.2 mm thick)	None	-/60/60

Specimen	Aperture	Seal description	Service insulation	FRL
G3 – PP pipe with outer diameter of 50 mm and pipe wall thickness of 4.6 mm.	Ø50 mm	Pipe capping: C/C 1 FR Board 50 mm 2-S, Protecta FR collar Ø55 on both faces, fixed to the batt with 40 mm long pigtail screws (intumescent size 50 mm deep × 3.2 mm thick)	None	-/60/60
G4 – PE-HD pipe with outer diameter of 160 mm and pipe wall thickness of 9.5 mm.	Ø160 mm	Pipe capping: C/C 1 FR Board 50 mm 2-S, Protecta FR collar Ø160 on both faces, fixed to the batt with 40 mm long pigtail screws (intumescent size 60 mm deep × 15 mm thick)	None	-/60/60

B.8 Test report – WF 395179

Table 76 Information about test report

Item	Information about test report
Report sponsor	Polyseam Ltd, St Andrews Road, Huddersfield, West Yorkshire, HD1, 6SB, UK.
Test laboratory	Warringtonfire, Chiltern House, Stocking Lane, High Wycombe, HP14, 4ND, UK.
Test date	The fire resistance test was completed on 6 February 2018.
Test standards	The test was done in accordance with BS EN 1363-1:2012 and BS EN 1366-3:2009.
Variation to test standards	None.
General description of tested specimen	<p>The supporting construction comprised of a 3 m wide × 3 m high steel stud / plasterboard clad partition, built in accordance with BS EN 1366-3:2009.</p> <p>The partition framing comprised of 50 mm × 25 mm high steel c-section studs fitted at nominally 600 mm centres and 52 mm wide × 35 mm high steel U-channel head and base track, with 50 mm thick, 33 kg/m³ density mineral wool insulation friction fitted between the studs. The framing was clad on both faces with 2 layers of 12.5 mm thick Type F plasterboard.</p> <p>The services referenced in this assessment report are J1-J3. All pipes and cables measured 1200 mm long with a minimum of 500 mm protruding from the exposed face. The mineral wool insulation within the partition wall was removed for 100 mm surrounding all apertures.</p>
Instrumentation	The test report states that the instrumentation was in accordance with BS EN 1363-1:2012 and BS EN 1366-3:2009.

The test specimen achieved the following results – see Table 77.

Table 77 Results summary for this test report

Specimen	Aperture	Seal description	Service insulation	FRL
J1 – Gerberit Mepla Alu-pex pipe with outer diameter of 16 mm and pipe wall thickness of 2.25 mm.	Ø56 mm	Pipe capping: C/C 2 FR Boards 50 mm 1-S, board edges sealed to the service with Protecta FR acrylic	20 mm thick Isover Climpipe Section Alu2 Glass wool	-/120/90
J2 – Gerberit Mepla Alu-pex pipe with outer diameter of 75 mm and pipe wall thickness of 4.6 mm.	Ø125 mm	Pipe capping: C/C 2 FR Boards 50 mm 1-S, board edges sealed to the service with Protecta FR acrylic	25 mm thick Isover Climpipe Section Alu2 Glass wool	-/120/90
J3 – Gerberit Mepla Alu-pex pipe with outer diameter of 75 mm and pipe wall thickness of 4.6 mm.	Ø175 mm	Pipe capping: C/C 2 FR Boards 50 mm 1-S, board edges sealed to the service with Protecta FR acrylic	50 mm thick Isover Climpipe Section Alu2 Glass wool	-/120/90

B.9 Test report – WF 392646

Table 78 Information about test report

Item	Information about test report
Report sponsor	Polyseam Ltd, St Andrews Road, Huddersfield, West Yorkshire, HD1, 6SB, UK.
Test laboratory	Warringtonfire, Chiltern House, Stocking Lane, High Wycombe, HP14, 4ND, UK.
Test date	The fire resistance test was completed on 29 November 2017.
Test standards	The test was done in accordance with BS EN 1363-1:2012 and BS EN 1366-3:2009.
Variation to test standards	None.
General description of tested specimen	<p>The supporting construction comprised of a 3 m wide × 3 m high steel stud / plasterboard clad partition, built in accordance with BS EN 1366-3:2009.</p> <p>The partition framing comprised of 50 mm × 25 mm high steel c-section studs fitted at nominally 600 mm centres and 52 mm wide × 35 mm high steel U-channel head and base track, with 50 mm thick, 33 kg/m³ density mineral wool insulation friction fitted between the studs. The framing was clad on both faces with 2 layers of 12.5 mm thick Type F plasterboard.</p> <p>The services referenced in this assessment report are H1 and H2. All pipes and cables measured 1200 mm long with a minimum of 500 mm protruding from the exposed face. The mineral wool insulation within the partition wall was removed for 100 mm surrounding all apertures.</p>
Instrumentation	The test report states that the instrumentation was in accordance with BS EN 1363-1:2012 and BS EN 1366-3:2009.

The test specimen achieved the following results – see Table 79.

Table 79 Results summary for this test report

Specimen	Aperture	Seal description	Service insulation	FRL
H1 – Steel pipe with outer diameter of 114 mm and pipe wall thickness of 2 mm.	Ø114 mm	Pipe capping: C/U 2 FR Boards 50 mm 1-S, board edges sealed to the service with Protecta FR acrylic	Protecta Service Coat FR-1 1000 micron thick extending 200 mm from the face of the fire seal on both sides	-/120/30
H2 – Steel pipe with outer diameter of 63.5 mm and pipe wall thickness of 1.6 mm.	Ø65 mm	Pipe capping: C/C 2 FR Boards 50 mm 1-S, board edges sealed to the service with Protecta FR acrylic	Protecta Service Coat FR-1 750 micron thick extending 200 mm from the face of the fire seal on both sides	-/120/-

B.10 Test report – WF 398517

Table 80 Information about test report

Item	Information about test report
Report sponsor	Polyseam Ltd, St Andrews Road, Huddersfield, West Yorkshire, HD1, 6SB, UK.
Test laboratory	Warringtonfire, Chiltern House, Stocking Lane, High Wycombe, HP14, 4ND, UK.
Test date	The fire resistance test was completed on 19 April 2018.
Test standards	The test was done in accordance with BS EN 1363-1:2012 and BS EN 1366-3:2009.
Variation to test standards	None.
General description of tested specimen	<p>The supporting construction comprised of a 3 m wide × 3 m high steel stud / plasterboard clad partition, built in accordance with BS EN 1366-3:2009.</p> <p>The partition framing comprised of 50 mm × 25 mm high steel c-section studs fitted at nominally 600 mm centres and 52 mm wide × 35 mm high steel U-channel head and base track, with 50 mm thick, 35 kg/m³ density mineral wool insulation friction fitted between the studs. The framing was clad on both faces with 2 layers of 12.5 mm thick Type F plasterboard.</p> <p>The services referenced in this assessment report are A1 to A3. All pipes and cables measured 1200 mm long with a minimum of 500 mm protruding from the exposed face. The mineral wool insulation within the partition wall was removed for 100 mm surrounding all apertures.</p>
Instrumentation	The test report states that the instrumentation was in accordance with BS EN 1363-1:2012 and BS EN 1366-3:2009.

The test specimen achieved the following results – see Table 81.

Table 81 Results summary for this test report

Specimen	Aperture	Seal description	Service insulation	FRL
A1 – Steel pipe with outer diameter of 114 mm and pipe wall thickness of 2 mm.	Ø114 mm	Pipe capping: C/U 2 FR Boards 50 mm 1-S.	Protecta Service Coat FR-1 1500 micron thick extending 200 mm from the face of the fire seal on both sides	-/90/30
A2 – Steel pipe with outer diameter of 63.5 mm and pipe wall thickness of 1.6 mm.	Ø63.5 mm	Pipe capping: C/U 2 FR Boards 50 mm 1-S.	Protecta Service Coat FR-1 1500 micron thick extending 200 mm from the face of the fire seal on both sides	-/90/60
A3 – PE pipe with outer diameter of 110 mm and pipe wall thickness of 10 mm.	Ø110 mm	Pipe capping: C/C 1 FR Boards 50 mm 2-S. Pipes friction fitted to board and sealed with Protecta FR Acrylic. Protecta FR Collar 110 mm fixed with 50 mm long pigtail screws and fitted on both faces (Intumescent material: 50 mm deep × 6 mm thick)	None	-/90/60

B.11 Test report – WF 384982 Revision A

Table 82 Information about test report

Item	Information about test report
Report sponsor	Polyseam Ltd, St Andrews Road, Huddersfield, West Yorkshire, HD1, 6SB, UK.
Test laboratory	Warringtonfire, Chiltern House, Stocking Lane, High Wycombe, HP14, 4ND, UK.
Test date	The fire resistance test was completed on 29 June 2017.
Test standards	The test was done in accordance with BS EN 1363-1:2012 and BS EN 1366-3:2009.
Variation to test standards	None.
General description of tested specimen	<p>The supporting construction comprised of a 3 m wide × 3 m high steel stud / plasterboard clad partition, built in accordance with BS EN 1366-3:2009.</p> <p>The partition framing comprised of 50 mm × 25 mm high steel c-section studs fitted at nominally 600 mm centres and 52 mm wide × 35 mm high steel U-channel head and base track, with 50 mm thick, 33 kg/m³ density mineral wool insulation friction fitted between the studs. The framing was clad on both faces with 2 layers of 12.5 mm thick Type F plasterboard.</p> <p>The services referenced in this assessment report are C2-C3 and D1-D3. All pipes and cables measured 1200 mm long with a minimum of 500 mm protruding from the exposed face. The mineral wool insulation within the partition wall was removed for 100 mm surrounding all apertures.</p>
Instrumentation	The test report states that the instrumentation was in accordance with BS EN 1363-1:2012 and BS EN 1366-3:2009.

The test specimen achieved the following results – see Table 83.

Table 83 Results summary for this test report

Specimen	Aperture	Seal description	Service insulation	FRL
C2 – PE pipe with outer diameter of 110 mm and pipe wall thickness of 3.4 mm.	Ø110 mm	Pipe capping: U/C 1 FR Boards 50 mm 2-S. Protecta FR Collar on each face fixed with 4 no. of 40 mm long pig tail screws per collar (Intumescent size: 50 mm wide × 6 mm thick)	None.	-/120/60
C3 – PVC pipe with outer diameter of 40 mm and pipe wall thickness of 1.9 mm.	Ø40 mm	Pipe capping: U/C 1 FR Boards 50 mm 2-S. Protecta FR Collar on each face fixed with 4 no. of 40 mm long pig tail screws per collar (Intumescent size: 30 mm wide × 2.4 mm thick)	None.	-/120/60

Specimen	Aperture	Seal description	Service insulation	FRL
D1 – PE pipe with outer diameter of 50 mm and pipe wall thickness of 3.0 mm.	Ø50 mm	Pipe capping: U/C 1 FR Boards 50 mm 2-S. Protecta FR Collar on each face fixed with 4 no. of 40 mm long pig tail screws per collar (Intumescent size: 50 mm wide × 3.0 mm thick)	None.	-/120/90
D2 – PE pipe with outer diameter of 50 mm and pipe wall thickness of 4.6 mm.	Ø50 mm	Pipe capping: U/C 1 FR Boards 50 mm 2-S. Protecta FR Collar on each face fixed with 4 no. of 40 mm long pig tail screws per collar (Intumescent size: 50 mm wide × 3.0 mm thick)	None.	-/120/60
D3 – PVC pipe with outer diameter of 50 mm and pipe wall thickness of 3.7 mm.	Ø50 mm	Pipe capping: U/C 1 FR Boards 50 mm 2-S. Protecta FR Collar on each face fixed with 4 no. of 40 mm long pig tail screws per collar (Intumescent size: 50 mm wide × 3.0 mm thick)	None.	-/120/120

B.12 Test report – WF 401855 Revision A

Table 84 Information about test report

Item	Information about test report
Report sponsor	Polyseam Ltd, St Andrews Road, Huddersfield, West Yorkshire, HD1, 6SB, UK.
Test laboratory	Warringtonfire, Chiltern House, Stocking Lane, High Wycombe, HP14, 4ND, UK.
Test date	The fire resistance test was completed on 5 July 2018.
Test standards	The test was done in accordance with BS EN 1363-1:2012 and BS EN 1366-3:2009.
Variation to test standards	None.
General description of tested specimen	<p>The supporting construction comprised of a 3 m wide × 3 m high steel stud / plasterboard clad partition, built in accordance with BS EN 1366-3:2009.</p> <p>The partition framing comprised of 50 mm × 25 mm high steel c-section studs fitted at nominally 600 mm centres and 52 mm wide × 35 mm high steel U-channel head and base track, with 50 mm thick, 35 kg/m³ density mineral wool insulation friction fitted between the studs. The framing was clad on both faces with 2 layers of 12.5 mm thick Type F plasterboard.</p> <p>The services referenced in this assessment report are C1-C3, G1-G3 and O. All pipes and cables measured 1200 mm long with a minimum of 500 mm protruding from the exposed face. The mineral wool insulation within the partition wall was removed for 100 mm surrounding all apertures.</p>
Instrumentation	The test report states that the instrumentation was in accordance with BS EN 1363-1:2012 and BS EN 1366-3:2009.

The test specimen achieved the following results – see Table 85.

Table 85 Results summary for this test report

Specimen	Aperture	Seal description	Service insulation	FRL
C1 – PP pipe with outer diameter of 200 mm and pipe wall thickness of 4.9 mm.	Ø221.6 mm	Pipe capping: C/C 2 FR Boards 50 mm 1-S with 6 layers of Protecta FR Wrap fitted in both batt layers (Intumescent size 50 mm wide × 1.8 mm thick each layer)	None.	-/90/90
C2 – PE pipe with outer diameter of 200 mm and pipe wall thickness of 6.2 mm.	Ø221.6 mm	Pipe capping: C/C 2 FR Boards 50 mm 1-S with 6 layers of Protecta FR Wrap fitted in both batt layers (Intumescent size 50 mm wide × 1.8 mm thick each layer)	None.	-/90/90

Specimen	Aperture	Seal description	Service insulation	FRL
C3 – PE pipe with outer diameter of 200 mm and pipe wall thickness of 4.9 mm.	Ø221.6 mm	Pipe capping: C/C 2 FR Boards 50 mm 1-S with 6 layers of Protecta FR Wrap fitted in both batt layers (Intumescent size 50 mm wide × 1.8 mm thick each layer)	None.	-/90/90
G1 – PP pipe with outer diameter of 200 mm and pipe wall thickness of 18.2 mm.	Ø221.6 mm	Pipe capping: C/C 2 FR Boards 50 mm 1-S with 6 layers of Protecta FR Wrap fitted in both batt layers (Intumescent size 50 mm wide × 1.8 mm thick each layer)	None.	-/120/90
G2 – PE pipe with outer diameter of 200 mm and pipe wall thickness of 18.2 mm.	Ø221.6 mm	Pipe capping: C/C 2 FR Boards 50 mm 1-S with 6 layers of Protecta FR Wrap fitted in both batt layers (Intumescent size 50 mm wide × 1.8 mm thick each layer)	None.	-/120/120
G3 – PVC pipe with outer diameter of 200 mm and pipe wall thickness of 11.9 mm.	Ø221.6 mm	Pipe capping: C/C 2 FR Boards 50 mm 1-S with 6 layers of Protecta FR Wrap fitted in both batt layers (Intumescent size 50 mm wide × 1.8 mm thick each layer)	None.	-/120/120
O – PE pipe with outer diameter of 315 mm and pipe wall thickness of 18.7 mm.	Aperture through fire seal batt: Ø351 mm Aperture size for batts: 500 mm high × 500 mm wide	Pipe capping: C/C 2 FR Boards 50 mm 1-S (160 kg/m ³), board edges sealed to the service with 10 layers of Protecta FR wrap (intumescent size: 50 mm wide and 1.8 mm thick)	None	-/60/60

B.13 Test report – WF 408361

Table 86 Information about test report

Item	Information about test report
Report sponsor	Polyseam Ltd, St Andrews Road, Huddersfield, West Yorkshire, HD1, 6SB, UK.
Test laboratory	Warringtonfire, Chiltern House, Stocking Lane, High Wycombe, HP14, 4ND, UK.
Test date	The fire resistance test was completed on 18 December 2018.
Test standards	The test was done in accordance with BS EN 1363-1:2012 and BS EN 1366-3:2009.
Variation to test standards	None.
General description of tested specimen	<p>The supporting construction comprised of a 3 m wide × 3 m high steel stud / plasterboard clad partition, built in accordance with BS EN 1366-3:2009.</p> <p>The partition framing comprised of 50 mm × 25 mm high steel c-section studs fitted at nominally 600 mm centres and 52 mm wide × 35 mm high steel U-channel head and base track, with 50 mm thick, 35 kg/m³ density mineral wool insulation friction fitted between the studs. The framing was clad on both faces with 2 layers of 12.5 mm thick Type F plasterboard.</p> <p>The services referenced in this assessment report are N1-N4 and P1-P4. All pipes and cables measured 1200 mm long with a minimum of 500 mm protruding from the exposed face. The mineral wool insulation within the partition wall was removed for 100 mm surrounding all apertures.</p>
Instrumentation	The test report states that the instrumentation was in accordance with BS EN 1363-1:2012 and BS EN 1366-3:2009.

The test specimen achieved the following results – see Table 87.

Table 87 Results summary for this test report

Specimen	Aperture	Seal description	Service insulation	FRL
N1 – PE pipe with outer diameter of 160 mm and pipe wall thickness of 4.9 mm.	Ø200 mm	Pipe capping: C/C 2 FR Boards 50 mm 1-S with 6 layers of Protecta FR Wrap fitted in both batt layers (Intumescent size 50 mm wide × 1.8 mm thick each layer)	9 mm thick Armaflex ACE elastomeric foam insulation - CS	-/60/60
N2 – PE pipe with outer diameter of 50 mm and pipe wall thickness of 3.0 mm.	Ø76 mm	Pipe capping: C/C 2 FR Boards 50 mm 1-S with 2 layers of Protecta FR Wrap fitted in both batt layers (Intumescent size 50 mm wide × 1.8 mm thick each layer)	9 mm thick Armaflex ACE elastomeric foam insulation - CS	-/60/60

Specimen	Aperture	Seal description	Service insulation	FRL
N3 – PE pipe with outer diameter of 50 mm and pipe wall thickness of 4.6 mm.	Ø76 mm	Pipe capping: C/C 2 FR Boards 50 mm 1-S with 2 layers of Protecta FR Wrap fitted in both batt layers (Intumescent size 50 mm wide × 1.8 mm thick each layer)	9 mm thick Armaflex ACE elastomeric foam insulation - CS	-/60/60
N4 – PE pipe with outer diameter of 160 mm and pipe wall thickness of 9.5 mm.	Ø76 mm	Pipe capping: C/C 2 FR Boards 50 mm 1-S with 6 layers of Protecta FR Wrap fitted in both batt layers (Intumescent size 50 mm wide × 1.8 mm thick each layer)	9 mm thick Armaflex ACE elastomeric foam insulation - CS	-/60/60
P1 – PP pipe with outer diameter of 160 mm and pipe wall thickness of 4.9 mm.	Ø200 mm	Pipe capping: C/C 2 FR Boards 50 mm 1-S with 6 layers of Protecta FR Wrap fitted in both batt layers (Intumescent size 50 mm wide × 1.8 mm thick each layer)	9 mm thick Armaflex ACE elastomeric foam insulation - CS	-/60/60
P2 – PP pipe with outer diameter of 50 mm and pipe wall thickness of 1.8 mm.	Ø76 mm	Pipe capping: C/C 2 FR Boards 50 mm 1-S with 2 layers of Protecta FR Wrap fitted in both batt layers (Intumescent size 50 mm wide × 1.8 mm thick each layer)	9 mm thick Kaiflex ST elastomeric foam insulation - CS	-/60/60
P3 – PP pipe with outer diameter of 50 mm and pipe wall thickness of 4.6 mm.	Ø76 mm	Pipe capping: C/C 2 FR Boards 50 mm 1-S with 2 layers of Protecta FR Wrap fitted in both batt layers (Intumescent size 50 mm wide × 1.8 mm thick each layer)	9 mm thick Kaiflex ST elastomeric foam insulation - CS	-/60/60

B.14 Test report – WF 407685

Table 88 Information about test report

Item	Information about test report
Report sponsor	Polyseam Ltd, St Andrews Road, Huddersfield, West Yorkshire, HD1, 6SB, UK.
Test laboratory	Warringtonfire, Chiltern House, Stocking Lane, High Wycombe, HP14, 4ND, UK.
Test date	The fire resistance test was completed on 29 November 2018.
Test standards	The test was done in accordance with BS EN 1363-1:2012 and BS EN 1366-3:2009.
Variation to test standards	None.
General description of tested specimen	<p>The supporting construction comprised of a 3 m wide × 3 m high steel stud / plasterboard clad partition, built in accordance with BS EN 1366-3:2009.</p> <p>The partition framing comprised of 60 mm × 25 mm high steel c-section studs fitted at nominally 600 mm centres and 62 mm wide × 35 mm high steel U-channel head and base track, with 60 mm thick, 33 kg/m³ density mineral wool insulation friction fitted between the studs. The framing was clad on both faces with 2 layers of 15 mm thick Type F plasterboard.</p> <p>The services referenced in this assessment report are A1-A5, D1-D3, H1-H3, J1-J3. All pipes and cables measured 1200 mm long with a minimum of 500 mm protruding from the exposed face. The mineral wool insulation within the partition wall was removed for 100 mm surrounding all apertures. The apertures for the considered specimens were unlined.</p>
Instrumentation	The test report states that the instrumentation was in accordance with BS EN 1363-1:2012 and BS EN 1366-3:2009.

The test specimen achieved the following results – see Table 89.

Table 89 Results summary for this test report

Specimen	Aperture	Seal description	Service insulation	FRL
A1 – Copper pipe with outer diameter of 12 mm and pipe wall thickness of 0.7 mm.	Ø12 mm	Pipe capping: C/C 2 FR Boards 50 mm 1-S with Protecta FR acrylic sealing pipe to batt on both faces	None	-/120/30
A2 – Steel pipe with outer diameter of 324 mm and pipe wall thickness of 6.35 mm.	Ø324 mm	Pipe capping: C/U 2 FR Boards 50 mm 1-S with Protecta FR acrylic sealing pipe to batt on both faces	None	-/120/-
A3 – Gerberit Mepla MLC pipe with outer diameter of 75 mm and pipe wall thickness of 4.6 mm.	Ø75 mm	Pipe capping: C/C 2 FR Boards 50 mm 1-S with Protecta FR acrylic sealing pipe to batt on both faces	None	-/120/-
A4 – Steel pipe with outer diameter of 63.5 mm and pipe wall thickness of 1.6 mm.	Ø63.5 mm	Pipe capping: C/U 2 FR Boards 50 mm 1-S with Protecta FR acrylic sealing pipe to batt on both faces	None	-/120/30

Specimen	Aperture	Seal description	Service insulation	FRL
A5 – Copper pipe with outer diameter of 54 mm and pipe wall thickness of 1.2 mm.	Ø54 mm	Pipe capping: C/C 2 FR Boards 50 mm 1-S with Protecta FR acrylic sealing pipe to batt on both faces	None	-/120/-
D1 – PE pipe with outer diameter of 160 mm and pipe wall thickness of 4.9 mm.	Ø181.6 mm	Pipe capping: C/C 2 FR Boards 60 mm 2-S with Protecta FR acrylic sealing pipe to batt on both faces. 6 layers of Protecta FR wrap fitted in both batt layers (Intumescent size: 50 mm wide × 1.8 mm thick)	None	-/120/120
D2 – PE pipe with outer diameter of 110 mm and pipe wall thickness of 10 mm.	Ø117.2 mm	Pipe capping: C/C 2 FR Boards 60 mm 2-S with Protecta FR acrylic sealing pipe to batt on both faces. 2 layers of Protecta FR wrap fitted in both batt layers (Intumescent size: 50 mm wide × 1.8 mm thick)	None	-/120/120
D3 – PE pipe with outer diameter of 160 mm and pipe wall thickness of 14.6 mm.	Ø181.6 mm	Pipe capping: C/C 2 FR Boards 60 mm 2-S with Protecta FR acrylic sealing pipe to batt on both faces. 6 layers of Protecta FR wrap fitted in both batt layers (Intumescent size: 50 mm wide × 1.8 mm thick)	None	-/120/120
H1 – PP pipe with outer diameter of 160 mm and pipe wall thickness of 4.9 mm.	Ø181.6 mm	Pipe capping: C/C 2 FR Boards 60 mm 2-S with Protecta FR acrylic sealing pipe to batt on both faces. 6 layers of Protecta FR wrap fitted in both batt layers (Intumescent size: 50 mm wide × 1.8 mm thick)	None	-/120/120
H2 – PP pipe with outer diameter of 110 mm and pipe wall thickness of 10 mm.	Ø117.2 mm	Pipe capping: C/C 2 FR Boards 60 mm 2-S with Protecta FR acrylic sealing pipe to batt on both faces. 2 layers of Protecta FR wrap fitted in both batt layers (Intumescent size: 50 mm wide × 1.8 mm thick)	None	-/120/120

Specimen	Aperture	Seal description	Service insulation	FRL
H3 – PP pipe with outer diameter of 160 mm and pipe wall thickness of 14.6 mm.	Ø181.6 mm	Pipe capping: C/C 2 FR Boards 60 mm 2-S with Protecta FR acrylic sealing pipe to batt on both faces. 6 layers of Protecta FR wrap fitted in both batt layers (Intumescent size: 50 mm wide × 1.8 mm thick)	None	-/120/120
J1 – PVC pipe with outer diameter of 160 mm and pipe wall thickness of 4.0 mm.	Ø181.6 mm	Pipe capping: C/C 2 FR Boards 60 mm 2-S with Protecta FR acrylic sealing pipe to batt on both faces. 6 layers of Protecta FR wrap fitted in both batt layers (Intumescent size: 50 mm wide × 1.8 mm thick)	None	-/120/120
J2 – PVC pipe with outer diameter of 110 mm and pipe wall thickness of 6.6 mm.	Ø117.2 mm	Pipe capping: C/C 2 FR Boards 60 mm 2-S with Protecta FR acrylic sealing pipe to batt on both faces. 2 layers of Protecta FR wrap fitted in both batt layers (Intumescent size: 50 mm wide × 1.8 mm thick)	None	-/120/120
J3 – PVC pipe with outer diameter of 160 mm and pipe wall thickness of 9.5 mm.	Ø181.6 mm	Pipe capping: C/C 2 FR Boards 60 mm 2-S with Protecta FR acrylic sealing pipe to batt on both faces. 6 layers of Protecta FR wrap fitted in both batt layers (Intumescent size: 50 mm wide × 1.8 mm thick)	None	-/120/120

B.15 Test report – WF 383813

Table 90 Information about test report

Item	Information about test report
Report sponsor	Polyseam Ltd, St Andrews Road, Huddersfield, West Yorkshire, HD1, 6SB, UK.
Test laboratory	Warringtonfire, Chiltern House, Stocking Lane, High Wycombe, HP14, 4ND, UK.
Test date	The fire resistance test was completed on 25 May 2017.
Test standards	The test was done in accordance with BS EN 1363-1:2012 and BS EN 1366-3:2009.
Variation to test standards	None.
General description of tested specimen	<p>The supporting construction comprised of a 3 m wide × 3 m high steel stud / plasterboard clad partition, built in accordance with BS EN 1366-3:2009.</p> <p>The partition framing comprised of 60 mm × 25 mm high steel c-section studs fitted at nominally 600 mm centres and 62 mm wide × 35 mm high steel U-channel head and base track, with 60 mm thick, 33 kg/m³ density mineral wool insulation friction fitted between the studs. The framing was clad on both faces with 2 layers of 15 mm thick Type F plasterboard.</p> <p>The services referenced in this assessment report are F1-F3 and S1-S6. All pipes and cables measured 1200 mm long with a minimum of 500 mm protruding from the exposed face. The mineral wool insulation within the partition wall was removed for 100 mm surrounding all apertures.</p>
Instrumentation	The test report states that the instrumentation was in accordance with BS EN 1363-1:2012 and BS EN 1366-3:2009.

The test specimen achieved the following results – see Table 91.

Table 91 Results summary for this test report

Specimen	Aperture	Seal description	Service insulation	FRL
F1 – PVC pipe with outer diameter of 110 mm and pipe wall thickness of 2.7 mm.	Ø117 mm	Pipe capping: C/C 2 FR Boards 50 mm 1-S with 2 layers of Protecta FR wrap fitted in both batt layers (Intumescent size: 50 mm wide × 1.8 mm thick)	None	-/120/120
F2 – PE pipe with outer diameter of 110 mm and pipe wall thickness of 3.4 mm.	Ø117 mm	Pipe capping: C/C 2 FR Boards 50 mm 1-S with 2 layers of Protecta FR wrap fitted in both batt layers (Intumescent size: 50 mm wide × 1.8 mm thick)	None	-/120/120
F3 – PP pipe with outer diameter of 110 mm and pipe wall thickness of 2.7 mm.	Ø117 mm	Pipe capping: C/C 2 FR Boards 50 mm 1-S Protecta FR Acrylic	None	-/120/120

Specimen	Aperture	Seal description	Service insulation	FRL
S1 – PE pipe with outer diameter of 40 mm and pipe wall thickness of 2.4 mm.	Ø44 mm	Pipe capping: C/C 2 FR Boards 50 mm 1-S with 1 layer of Protecta FR wrap fitted in both batt layers (Intumescent size: 50 mm wide × 1.8 mm thick)	None	-/120/120
S2 – PVC pipe with outer diameter of 40 mm and pipe wall thickness of 1.9 mm.	Ø44 mm	Pipe capping: C/C 2 FR Boards 50 mm 1-S with 1 layer of Protecta FR wrap fitted in both batt layers (Intumescent size: 50 mm wide × 1.8 mm thick)	None	-/120/120
S3 – PP pipe with outer diameter of 40 mm and pipe wall thickness of 1.8 mm.	Ø44 mm	Pipe capping: C/C 2 FR Boards 50 mm 1-S with 1 layer of Protecta FR wrap fitted in both batt layers (Intumescent size: 50 mm wide × 1.8 mm thick)	None	-/120/120
S4 – PE pipe with outer diameter of 40 mm and pipe wall thickness of 4.6 mm.	Ø44 mm	Pipe capping: C/C 2 FR Boards 50 mm 1-S with 1 layer of Protecta FR wrap fitted in both batt layers (Intumescent size: 50 mm wide × 1.8 mm thick)	None	-/120/120
S5 – PVC pipe with outer diameter of 40 mm and pipe wall thickness of 3.0 mm.	Ø44 mm	Pipe capping: C/C 2 FR Boards 50 mm 1-S with 1 layer of Protecta FR wrap fitted in both batt layers (Intumescent size: 50 mm wide × 1.8 mm thick)	None	-/120/120
S6 – PP pipe with outer diameter of 40 mm and pipe wall thickness of 5.5 mm.	Ø44 mm	Pipe capping: C/C 2 FR Boards 50 mm 1-S with 1 layer of Protecta FR wrap fitted in both batt layers (Intumescent size: 50 mm wide × 1.8 mm thick)	None	-/120/120

B.16 Test report – WF 394232

Table 92 Information about test report

Item	Information about test report
Report sponsor	Polyseam Ltd, St Andrews Road, Huddersfield, West Yorkshire, HD1, 6SB, UK.
Test laboratory	Warringtonfire, Chiltern House, Stocking Lane, High Wycombe, HP14, 4ND, UK.
Test date	The fire resistance test was completed on 11 January 2018.
Test standards	The test was done in accordance with BS EN 1363-1:2012 and BS EN 1366-3:2009.
Variation to test standards	None.
General description of tested specimen	The supporting construction comprised of a 3 m wide × 3 m high × 150 mm thick blockwork wall. The services referenced in this assessment report are F1 and F2. All pipes and cables measured 1200 mm long with a minimum of 500 mm protruding from the exposed face. The mineral wool insulation within the partition wall was removed for 100 mm surrounding all apertures.
Instrumentation	The test report states that the instrumentation was in accordance with BS EN 1363-1:2012 and BS EN 1366-3:2009.

The test specimen achieved the following results – see Table 93.

Table 93 Results summary for this test report

Specimen	Aperture	Seal description	Service insulation	FRL
F1 – Steel pipe with outer diameter of 40 mm and pipe wall thickness of 1.0 mm.	Ø100 mm	Pipe capping: C/U 1 FR Boards 60 mm 2-S with Protecta FR acrylic on both faces sealing insulation to batt	30 mm thick foil faced rock mineral wool – CS (80 kg/m ³ density)	-/240/60
F2 – Steel pipe with outer diameter of 325 mm and pipe wall thickness of 6.35 mm.	Ø425 mm	Pipe capping: C/U 1 FR Boards 60 mm 2-S with Protecta FR acrylic on both faces sealing insulation to batt	50 mm thick foil faced rock mineral wool – CS (80 kg/m ³ density)	-/180/60

B.17 Test report – WF 19723

Table 94 Information about test report

Item	Information about test report
Report sponsor	Polyseam Ltd, St Andrews Road, Huddersfield, West Yorkshire, HD1, 6SB, UK.
Test laboratory	Warringtonfire NV, Ottergemsesteenweg-Zuid 711, B-9000 Gent, Belgie.
Test date	The fire resistance test was completed on 25 June 2019.
Test standards	The test was done in accordance with BS EN 1363-1:2012 and BS EN 1366-3:2009.
Variation to test standards	None.
General description of tested specimen	The supporting construction comprised of a cross laminated timber floor M Crosslam 150 5s NSI DL. The material was Spruce (Picea abies) and the slab dimensions were 1320 mm × 3300 mm. The slab thickness is 150 mm. The density is 480 kg/m ³ .
Instrumentation	The test report states that the instrumentation was in accordance with BS EN 1363-1:2012 and BS EN 1366-3:2009.

The test specimen achieved the following results – see Table 95.

Table 95 Results summary for this test report

Specimen	Aperture	Seal description	Service insulation	FRL
R1 cables: A1 - ø 11	1200 mm × 600 mm	1 FR Boards 50 mm 1-S with Protecta FR Coating	-	-/90/90
A2 - ø 12				-/90/30
A3 - ø 10				-/90/60
B - ø 19				-/90/90
C1 - ø 42				-/90/60
C2 - ø 48				-/90/60
C3 - ø 35				-/90/60
P Tray 500 mm				-/90/60
D1 - ø 58				-/90/60
D2 - ø 67				-/90/90
E - ø 25				-/90/60
Ladder 300 mm				-/90/90
D3 - ø 52				-/90/90
Ladder 200 mm				-/90/90
F bundle - ø 15				-/90/60
G1 - ø 21				-/90/30
G2 - ø 15				-/90/30
PE-X conduit with diameter 25/15 mm with wall thickness 1.0/1.2 mm C/C				-/90/90
UP Tray 500 mm				-/90/60

Specimen	Aperture	Seal description	Service insulation	FRL
R2 - ø 60 mm steel pipe with wall thickness of 1.5 mm	1200 mm x 600 mm	Pipe capping: C/U 1 FR Boards 50 mm 1-S with Protecta FR Coating	20 mm thick Glass wool (LI) in a length of 500 mm	-/90/60
R3 - ø 273 mm steel pipe with wall thickness of 6.35 mm			25 mm thick Glass wool (LI) in a length of 500 mm	-/90/60
R4 - ø 15 mm Copper pipe with wall thickness of 0.7 mm			20 mm thick Glass wool (LI) in a length of 500 mm	-/90/90
R5 - ø 54 mm Copper pipe with wall thickness of 1.2 mm			20 mm thick Glass wool (LI) in a length of 500 mm	-/90/90
R6 - ø 16 mm Geberit Mepla Alupex pipe with wall thickness of 2.25 mm			20 mm thick Glass wool (LI) in a length of 500 mm	-/90/60
R7 - ø 75 mm Geberit Mepla Alupex pipe with wall thickness of 4.6 mm			25 mm thick Glass wool (LI) in a length of 500 mm	-/90/60

B.18 Test report – WF 419414

Table 96 Information about test report

Item	Information about test report
Report sponsor	Polyseam Ltd, St Andrews Road, Huddersfield, West Yorkshire, HD1, 6SB, UK.
Test laboratory	Warringtonfire, Chiltern House, Stocking Lane, High Wycombe, HP14, 4ND, UK.
Test date	The fire resistance test was completed on 24 October 2019.
Test standards	The test was done in accordance with BS EN 1363-1:2012 and BS EN 1366-3:2009.
Variation to test standards	None.
General description of tested specimen	The supporting construction comprised of a 3 m wide × 3 m high × 100 mm thick Nordisk Massivtre (Nordic Solid Wood) CLT partition wall section. The wall included two horizontal joints located at 600 mm from the threshold and 1800 mm from the threshold. A timber section stated by the client as European Redwood with a nominal density of 510 kg/m ³ density sources from the TRADA timber database, measuring 3 m wide and 95 mm high and 12 mm thick was used to connect the three section of the CLT wall via a loose tongue joint. Lamell 1 is 18.5 mm thick, Lamell 2 is 21 mm thick, lamell 3 is 21 mm thick, lamell 4 is 21 mm thick and lamell 5 is 18.5 mm thick. The services referenced in this assessment report are A1-A3, B1-B3 and H. All pipes and cables measured 1200 mm long with a minimum of 500 mm protruding from the exposed face.
Instrumentation	The test report states that the instrumentation was in accordance with BS EN 1363-1:2012 and BS EN 1366-3:2009.

The test specimen achieved the following results – see Table 97.

Table 97 Results summary for this test report

Specimen	Aperture	Seal description	Service insulation	FRL
A1 – Steel pipe with outer diameter of 165 mm and pipe wall thickness of 4.5 mm.	Ø198.2 mm	Pipe capping: C/U 2 FR Boards 50 mm 1-S with Protecta FR acrylic on both faces sealing insulation to batt. 2 layers of Protecta FR wrap on both faces between pipe and batt (Intumescent size: 50 mm wide × 1.8 mm thick). FR boards are pattress fitted.	13 mm thick Armacell Ace Elastomeric foam - CS	-/120/90
A2 – Steel pipe with outer diameter of 324 mm and pipe wall thickness of 6.35 mm.	Ø398.8 mm	Pipe capping: C/U 2 FR Boards 50 mm 1-S with Protecta FR acrylic on both faces sealing insulation to batt. 3 layers of Protecta FR wrap on both faces between pipe and batt (Intumescent size: 50 mm wide × 1.8 mm thick). FR boards are pattress fitted.	32 mm thick Armacell Ace Elastomeric foam - CS	-/120/90

Specimen	Aperture	Seal description	Service insulation	FRL
<p>A3 – Cable penetration consisting of Perforated steel cable tray 500 mm wide × 70 mm high</p> <p>10 No. of Type A1 cables</p> <p>10 No. of Type A2 cables</p> <p>10 No. of Type A3 cables</p> <p>2 No. of Type E cables</p> <p>2 No. of Type B cables</p> <p>1 No. of Type C1 cables</p> <p>1 No. of Type C2 cables</p> <p>1 No. of Type C3 cables</p>		<p>2 FR Boards 50 mm 1-S pattress fitted with Protecta FR acrylic on both faces.</p>	None	<p>Insulation:</p> <p>Tray: 120 minutes</p> <p>Cables A1: 120 minutes</p> <p>Cables A2: 120 minutes</p> <p>Cables A3: 120 minutes</p> <p>Cables E: 98 minutes</p> <p>Cables B: 109 minutes</p> <p>Cables C1: 107 minutes</p> <p>Cables C2: 120 minutes</p> <p>Cables C3: 120 minutes</p>
<p>B1 – PP pipe with outer diameter of 110 mm and pipe wall thickness of 15.1 mm.</p>	Ø117.2 mm	<p>Pipe capping: U/U</p> <p>2 FR Boards 50 mm 1-S with Protecta FR acrylic on both faces. 2 layers of Protecta FR wrap on both faces between pipe and batt (Intumescent size: 50 mm wide × 1.8 mm thick). FR boards are pattress fitted.</p>	None	-/120/120
<p>B2 – PVC pipe with outer diameter of 32mm and pipe wall thickness of 2.4 mm.</p>	Ø32 mm	<p>Pipe capping: U/C</p> <p>2 FR Boards 50 mm 1-S with Protecta FR acrylic on both faces.</p>	None	-/120/120
<p>B3 – PE pipe with outer diameter of 32mm and pipe wall thickness of 2.0 mm.</p>	Ø32 mm	<p>Pipe capping: U/C</p> <p>2 FR Boards 50 mm 1-S with Protecta FR acrylic on both faces.</p>	None	-/120/120
<p>H – Gerberit Mepla Alupex pipe with outer diameter of 75 mm and pipe wall thickness of 4.6 mm.</p>	Ø75 mm aperture within batt and wall aperture is 135 mm × 135 mm.	<p>Pipe capping: C/C</p> <p>2 FR Boards 50 mm 1-S with Protecta FR acrylic on both faces sealing insulation to batt. FR boards are pattress fitted.</p>	500 mm long and 20 mm thick stonewool 80 kg/m ³ – localised interrupted	-/120/120

B.19 Test report – WF 410203

Table 98 Information about test report

Item	Information about test report
Report sponsor	Polyseam Ltd, St Andrews Road, Huddersfield, West Yorkshire, HD1, 6SB, UK.
Test laboratory	Warringtonfire, Chiltern House, Stocking Lane, High Wycombe, HP14, 4ND, UK.
Test date	The fire resistance test was completed on 17 February 2019.
Test standards	The test was done in accordance with BS EN 1363-1:2012 and BS EN 1366-3:2009.
Variation to test standards	None.
General description of tested specimen	The supporting construction comprised of a 1.5 m wide × 1.5 m high × 75 mm thick blockwork wall. The aperture size is 1100 mm high × 1100 mm wide × 75 mm deep.
Instrumentation	The test report states that the instrumentation was in accordance with BS EN 1363-1:2012 and BS EN 1366-3:2009.

The test specimen achieved the following results – see Table 99.

Table 99 Results summary for this test report

Specimen	Aperture	Seal description	FRL
Blank seal	1100 mm high × 1100 mm wide × 75 mm deep	1 number of 60 mm thick Protecta FR board 60 2-S incorporating a horizontal butt joint 550 mm from the head of the fire seal, with Protecta FR Acrylic applied on the board edges and friction fitted within the supporting construction. The FR board is fitted flush with the exposed face of the supporting construction.	-/120/90

B.20 Test report – WF 19479A

Table 100 Information about test report

Item	Information about test report
Report sponsor	Polyseam Ltd, St Andrews Road, Huddersfield, West Yorkshire, HD1, 6SB, UK.
Test laboratory	WFRGENT NV, Ottergemsesteenweg-Zuid 711, B-9000 Gent, Belgie.
Test date	The fire resistance test was completed on 14 January 2019.
Test standards	The test was done in accordance with BS EN 1366-4:2009.
Variation to test standards	None.
General description of tested specimen	The supporting construction composed of a steel frame (thickness 50 mm with studs at 600 mm centre to centre) covered with two layers of 12.5 mm thick gypsum boards Type F on both sides. The wall is insulated internally with stonewool boards (density 33 kg/m ³). The mineral wool insulation in the wall has been removed for 100 mm around the apertures.
Instrumentation	The test report states that the instrumentation was in accordance with BS EN 1363-1:2012 and BS EN 1366-4:2009.

The test specimen achieved the following results – see Table 101.

Table 101 Results summary for this test report

Specimen	Aperture	Overall seal dimensions	Sealing	FRL
1 - Blank seal	1100 mm × 1100 mm	1200 mm × 1200 mm	Protecta FR Board 50 mm on both exposed and unexposed sides	-/120/120
2 – Blank seal	1100 mm × 550 mm	1200 mm × 600 mm	Protecta FR Board 50 mm on both exposed and unexposed sides	-/120/120

B.21 Test report – UL 4788787025

Table 102 Information about test report

Item	Information about test report
Report sponsor	Polyseam Ltd, 15 St Andrews Road, Huddersfield, West Yorkshire, HD1, 6SB, UK.
Test laboratory	UL International (UK) Ltd, 220, Cygnet Court, Centre Park, Warrington, WA1 1PP.
Test date	The fire resistance test was completed on 28 February 2019.
Test standards	The test was done in accordance with BS EN 1366-3:2009 and BS EN 1366-4:2009.
Variation to test standards	None.
General description of tested specimen	The supporting construction was 5000 mm × 8000 mm × 150 mm thick made of AAC blockwork. The wall incorporated five openings with dimensions of 2400 mm × 1200 mm.
Instrumentation	The test report states that the instrumentation was in accordance with BS EN 1363-1:2012 and BS EN 1366-4:2009.

The test specimen achieved the following results – see Table 103.

Table 103 Results summary for this test report

Specimen	Aperture	Sealing	FRL
2 - Blank seal	2400 mm × 1200 mm.	Protecta FR Board 2-S with 1mm WFT Protecta FR coating on both faces. Stonewool batt of 50 mm thickness with nominal density 160 kg/m ³ . Joint material is Protecta FR Acrylic.	-/90/60
5 – Blank seal	2400 mm × 1200 mm.	Protecta FR Board 2-S with 1mm WFT Protecta FR coating on both faces. Stonewool batt of 50 mm thickness with nominal density 150 kg/m ³ . Joint material is Protecta FR Acrylic.	-/90/60

B.22 Test report – WF 375339

Table 104 Information about test report

Item	Information about test report
Report sponsor	Polyseam AS, Shaw Park, Silver Street, Huddersfield, West Yorkshire, HD5, 9AF, UK.
Test laboratory	Warringtonfire, Chiltern House, Stocking Lane, High Wycombe, HP14, 4ND, UK.
Test date	The fire resistance test was completed on 28 February 2019.
Test standards	The test was done in accordance with BS EN 1366-3:2009 and BS EN 1366-4:2009.
Variation to test standards	None.
General description of tested specimen	<p>The supporting construction comprised of a 3 m wide × 3 m high steel stud / plasterboard clad partition, built in accordance with BS EN 1366-3:2009.</p> <p>The partition framing comprised of 50 mm × 25 mm high steel c-section studs fitted at nominally 600 mm centres and 52 mm wide × 35 mm high steel U-channel head and base track, with 60 mm thick, 35 kg/m³ density mineral wool insulation friction fitted between the studs. The framing was clad on both faces with 1 layer of 12.5 mm thick Type F plasterboard.</p> <p>The service referenced in this assessment report is A. All pipes and cables measured 1200 mm long with a minimum of 500 mm protruding from the exposed face. The mineral wool insulation within the partition wall was removed for 100 mm surrounding all apertures.</p>
Instrumentation	The test report states that the instrumentation was in accordance with BS EN 1363-1:2012 and BS EN 1366-4:2009.

The test specimen achieved the following results – see Table 105.

Table 105 Results summary for this test report

Specimen	Aperture	Sealing	FRL
A – blank seal	600 mm high × 1200 mm wide	2 × 30 mm thick Protecta FR Board 1-S (160 kg/m ³) friction fitted, flush to the faces with a 15 mm air space, sealed to the plasterboard with Protecta FR Acrylic	-/45/15

B.23 Test report – WF 375344

Table 106 Information about test report

Item	Information about test report
Report sponsor	Polyseam AS, Shaw Park, Silver Street, Huddersfield, West Yorkshire, HD5, 9AF, UK.
Test laboratory	Warringtonfire, Chiltern House, Stocking Lane, High Wycombe, HP14, 4ND, UK.
Test date	The fire resistance test was completed on 26 October 2016.
Test standards	The test was done in accordance with BS EN 1366-3:2009 and BS EN 1366-4:2009.
Variation to test standards	None.
General description of tested specimen	The supporting construction comprised of a 150 mm thick reinforced AAC blockwork / lintel wall in front of a 1.5 m × 1.5 m furnace. The services referenced in this assessment report are G and H. All pipes and cables measured 1200 mm long with a minimum of 500 mm protruding from the exposed face.
Instrumentation	The test report states that the instrumentation was in accordance with BS EN 1363-1:2012 and BS EN 1366-4:2009.

The test specimen achieved the following results – see Table 107.

Table 107 Results summary for this test report

Specimen	Aperture	Sealing	FRL
G – blank seal	220 mm long × 220 mm wide × 150 mm deep	2 × 60 mm thick Protecta FR Board 2-S (160 kg/m ³) friction fitted, flush to the faces with a 30 mm air space, sealed to the plasterboard with Protecta FR Acrylic	-/240/240
H – blank seal	220 mm long × 220 mm wide × 150 mm deep	2 × 60 mm thick Protecta FR Board 2-S (160 kg/m ³) friction fitted, flush to the faces with a 30 mm air space, sealed to the plasterboard with Protecta FR Acrylic	-/240/240

B.24 Test report – WF 375797

Table 108 Information about test report

Item	Information about test report
Report sponsor	Polyseam AS, Shaw Park, Silver Street, Huddersfield, West Yorkshire, HD5, 9AF, UK.
Test laboratory	Warringtonfire, Chiltern House, Stocking Lane, High Wycombe, HP14, 4ND, UK.
Test date	The fire resistance test was completed on 9 March 2017.
Test standards	The test was done in accordance with BS EN 1366-3:2009 and BS EN 1366-4:2009.
Variation to test standards	None.
General description of tested specimen	The supporting construction comprised of a 4000 mm × 3000 mm × 150 mm thick aerated concrete floor. The services referenced in this assessment report are B-E. All pipes and cables measured 1200 mm long with a minimum of 500 mm protruding from the exposed face.
Instrumentation	The test report states that the instrumentation was in accordance with BS EN 1363-1:2012 and BS EN 1366-4:2009.

The test specimen achieved the following results – see Table 109.

Table 109 Results summary for this test report

Specimen	Seal type	FRL
B	1200 mm long by 600 mm wide aperture. The aperture was sealed with two 60 mm thick Polyseam “Protecta” FR Board 60 2-S ablative coated batts, with a nominal density of 160 kg/m ³ . The batt seal was friction fitted into the aperture with a nominal 10 mm wide bead of Protecta FR Acrylic applied. The batts were fitted flush to the exposed and unexposed face with a 30 mm air gap.	-/180/180
C	1200 mm long by 600 mm wide aperture. The aperture was sealed with one 60 mm thick Polyseam “Protecta” FR Board 60 2-S ablative coated batts, with a nominal density of 160 kg/m ³ . The batt seal was friction fitted into the aperture with a nominal 10 mm wide bead of Protecta FR Acrylic applied. The batts were fitted flush to the exposed and unexposed face with a 30 mm air gap.	-/240/120
D	The service is 160 mm diameter by 4.9 mm wall thickness PP pipe. The aperture size is 180 mm diameter. The penetration service was provided with a single Polyseam Protecta FR Collar +160 pipe collar fitted to the underside of the floor. The collar was filled with 10 layers of 1.5 mm thick graphite based intumescent. The annular gap was filled with 40 mm deep Rockwool “Flex slab” stonewool insulation with a density of 33 kg/m ³ . This was filled to a depth of 50 mm from the underside of the floor giving a 10 mm gap which was filled with Protecta FR acrylic flush to the floor.	-/240/180
E	The service is 160 mm diameter by 14.6 mm wall thickness PP pipe. The aperture size is 180 mm diameter. The penetration service was provided with a single Polyseam Protecta FR Collar +160 pipe collar fitted to the underside of the floor. The collar was filled with 10 layers of 1.5 mm thick graphite based intumescent. The annular gap was filled with 40 mm deep Rockwool “Flex slab” stonewool insulation with a density of 33 kg/m ³ . This was filled to a depth of 50 mm from the underside of the floor giving a 10 mm gap which was filled with Protecta FR acrylic flush to the floor.	-/180/180

B.25 Test report – WF 376483

Table 110 Information about test report

Item	Information about test report
Report sponsor	Polyseam AS, Shaw Park, Silver Street, Huddersfield, West Yorkshire, HD5, 9AF, UK.
Test laboratory	Warringtonfire, Chiltern House, Stocking Lane, High Wycombe, HP14, 4ND, UK.
Test date	The fire resistance test was completed on 29 November 2016.
Test standards	The test was done in accordance with BS EN 1366-3:2009 and BS EN 1366-4:2009.
Variation to test standards	None.
General description of tested specimen	<p>The supporting construction comprised of a 3 m wide × 3 m high steel stud / plasterboard clad partition, built in accordance with BS EN 1366-3:2009.</p> <p>The partition framing comprised of 50 mm × 25 mm high steel c-section studs fitted at nominally 600 mm centres and 52 mm wide × 35 mm high steel U-channel head and base track, with 60 mm thick, 35 kg/m³ density mineral wool insulation friction fitted between the studs. The framing was clad on both faces with 2 layers of 12.5 mm thick Type F plasterboard.</p> <p>The services referenced in this assessment report are E-M, P-S, U-Z and fire seal batts. All pipes and cables measured 1200 mm long with a minimum of 500 mm protruding from the exposed face. The mineral wool insulation within the partition wall was removed for 100 mm surrounding all apertures.</p>
Instrumentation	The test report states that the instrumentation was in accordance with BS EN 1363-1:2012 and BS EN 1366-4:2009.

The test specimen achieved the following results – see Table 111.

Table 111 Results summary for this test report

Specimen	Aperture	Seal description	Service insulation	FRL
E – PP pipe with outer diameter of 50 mm and pipe wall thickness of 1.8 mm.	ø64 mm	Pipe capping: U/U Protecta FR collar fitted both faces with intumescent size 3 mm thick × 30 mm wide and Rock mineral fibre backing (33 kg/m ³) with size 7 mm wide × 20 mm deep	None	-/90/60
F – PP pipe with outer diameter of 50 mm and pipe wall thickness of 4.6 mm.	ø64 mm	Pipe capping: U/U Protecta FR collar fitted both faces with intumescent size 3 mm thick × 30 mm wide and Rock mineral fibre backing (33 kg/m ³) with size 7 mm wide × 20 mm deep	None	-/90/60
Fire seal batt 1 – incorporating G, H, I, J	445 mm high × 445 mm wide	1 of 50 mm thick Protecta FR Board 2-S (160 kg/m ³ density). Friction fitted, sealed to the plasterboard with Protecta FR Acrylic	-	-/60/45

Specimen	Aperture	Seal description	Service insulation	FRL
G – PVC pipe with outer diameter of 110 mm and pipe wall thickness of 2.7 mm.	Ø110 mm	Pipe capping: U/C Protecta FR collar fitted both faces with intumescent size 6 mm thick × 30 mm wide	None	-/90/60
H – PVC pipe with outer diameter of 110 mm and pipe wall thickness of 6.6 mm.	Ø110 mm	Pipe capping: U/C Protecta FR collar fitted both faces with intumescent size 6 mm thick × 30 mm wide	None	-/90/60
I – PE pipe with outer diameter of 110 mm and pipe wall thickness of 10.0 mm.	Ø110 mm	Pipe capping: U/C Protecta FR collar fitted both faces with intumescent size 6 mm thick × 30 mm wide	None	-/60/45
J – PE pipe with outer diameter of 110 mm and pipe wall thickness of 3.4 mm.	Ø110 mm	Pipe capping: U/C Protecta FR collar fitted both faces with intumescent size 6 mm thick × 30 mm wide	None	-/90/45
K – PVC pipe with outer diameter of 50 mm and pipe wall thickness of 4.6 mm.	Ø64 mm	Pipe capping: U/U Protecta FR collar fitted both faces with intumescent size 3 mm thick × 30 mm wide and Rock mineral fibre backing (33 kg/m ³) with size 7 mm wide × 20 mm deep	None	-/90/60
L – PE pipe with outer diameter of 50 mm and pipe wall thickness of 3.0 mm.	Ø64 mm	Pipe capping: U/U Protecta FR collar fitted both faces with intumescent size 3 mm thick × 30 mm wide and Rock mineral fibre backing (33 kg/m ³) with size 7 mm wide × 20 mm deep	None	-/90/45
M – PE pipe with outer diameter of 50 mm and pipe wall thickness of 4.6 mm.	Ø64 mm	Pipe capping: U/U Protecta FR collar fitted both faces with intumescent size 3 mm thick × 30 mm wide and Rock mineral fibre backing (33 kg/m ³) with size 7 mm wide × 20 mm deep	None	-/90/45
Fire seal batt 2 – incorporating P, Q, R, S	600 mm high × 1200 mm wide	1 of 50 mm thick Protecta FR Board 2-S (160 kg/m ³ density). Friction fitted, sealed to the plasterboard with Protecta FR Acrylic	-	-/60/45

Specimen	Aperture	Seal description	Service insulation	FRL
P – PE pipe with outer diameter of 50 mm and pipe wall thickness of 3.0 mm.	Ø50 mm	Pipe capping: U/C Protecta FR collar fitted both faces with intumescent size 6 mm thick × 30 mm wide	None	-/90/45
Q – PVC pipe with outer diameter of 50 mm and pipe wall thickness of 3.7 mm.	Ø50 mm	Pipe capping: U/C Protecta FR collar fitted both faces with intumescent size 6 mm thick × 30 mm wide	None	-/90/30
R – PE pipe with outer diameter of 50 mm and pipe wall thickness of 4.6 mm.	Ø50 mm	Pipe capping: U/C Protecta FR collar fitted both faces with intumescent size 6 mm thick × 30 mm wide	None	-/90/45
S – PVC pipe with outer diameter of 40 mm and pipe wall thickness of 1.9 mm.	Ø40 mm	Pipe capping: U/C Protecta FR collar fitted both faces with intumescent size 2.4 mm thick × 30 mm wide	None	-/90/45
U – PP pipe with outer diameter of 110 mm and pipe wall thickness of 6.6 mm.	Ø130 mm	Pipe capping: U/U Protecta FR collar fitted both faces with intumescent size 6 mm thick × 50 mm wide. Protecta FR Acrylic applied to a width of 10 mm and a depth of 25 mm.	None	-/90/60
U – PVC pipe with outer diameter of 160 mm and pipe wall thickness of 9.5 mm.	Ø180 mm	Pipe capping: U/U Protecta FR collar fitted both faces with intumescent size 15 mm thick × 60 mm wide. Rock mineral fibre applied to a width of 10 mm and a depth of 20 mm.	None	-/90/90
W – PP pipe with outer diameter of 160 mm and pipe wall thickness of 14.6 mm.	Ø180 mm	Pipe capping: U/U Protecta FR collar fitted both faces with intumescent size 15 mm thick × 60 mm wide. Protecta FR Acrylic applied to a width of 10 mm and a depth of 25 mm.	None	-/90/45

Specimen	Aperture	Seal description	Service insulation	FRL
X – PE pipe with outer diameter of 160 mm and pipe wall thickness of 4.9 mm.	Ø180 mm	Pipe capping: U/U Protecta FR collar fitted both faces with intumescent size 15 mm thick × 60 mm wide. Rock mineral fibre applied to a width of 10 mm and a depth of 20 mm.	None	-/90/90
Y – PE pipe with outer diameter of 160 mm and pipe wall thickness of 14.6 mm.	Ø180 mm	Pipe capping: U/U Protecta FR collar fitted both faces with intumescent size 15 mm thick × 60 mm wide. Rock mineral fibre applied to a width of 10 mm and a depth of 20 mm.	None	-/90/90
Z – PE pipe with outer diameter of 160 mm and pipe wall thickness of 14.6 mm.	Ø180 mm	Pipe capping: U/U Protecta FR collar fitted both faces with intumescent size 15 mm thick × 60 mm wide. Protecta FR Acrylic applied to a width of 10 mm and a depth of 20 mm.	None	-/90/90

B.26 Test report – WF 379105

Table 112 Information about test report

Item	Information about test report
Report sponsor	Polyseam AS, Shaw Park, Silver Street, Huddersfield, West Yorkshire, HD5, 9AF, UK.
Test laboratory	Warringtonfire, Chiltern House, Stocking Lane, High Wycombe, HP14, 4ND, UK.
Test date	The fire resistance test was completed on 26 January 2017.
Test standards	The test was done in accordance with BS EN 1366-3:2009 and BS EN 1366-4:2009.
Variation to test standards	None.
General description of tested specimen	The supporting construction comprised of a 150 mm thick reinforced AAC blockwork / lintel wall in front of a 1.5 m × 1.5 m furnace. The services referenced in this assessment report are A-D. All pipes and cables measured 1200 mm long with a minimum of 500 mm protruding from the exposed face.
Instrumentation	The test report states that the instrumentation was in accordance with BS EN 1363-1:2012 and BS EN 1366-4:2009.

The test specimen achieved the following results – see Table 113.

Table 113 Results summary for this test report

Specimen	Aperture	Sealing	FRL
A	450 mm long × 450 mm wide × 150 mm deep	2 × 60 mm thick Protecta FR Board 2-S (160 kg/m ³) friction fitted, flush to the faces with a 30 mm air space, sealed to the plasterboard with Protecta FR Acrylic	-/240/240
B			
C			
D			

B.27 Test report – WF 380112

Table 114 Information about test report

Item	Information about test report
Report sponsor	Polyseam AS, Shaw Park, Silver Street, Huddersfield, West Yorkshire, HD5, 9AF, UK.
Test laboratory	Warringtonfire, Chiltern House, Stocking Lane, High Wycombe, HP14, 4ND, UK.
Test date	The fire resistance test was completed on 16 February 2017.
Test standards	The test was done in accordance with BS EN 1366-3:2009 and BS EN 1366-4:2009.
Variation to test standards	None.
General description of tested specimen	<p>The supporting construction comprised of a 3 m wide × 3 m high steel stud / plasterboard clad partition, built in accordance with BS EN 1366-3:2009.</p> <p>The partition framing comprised of 50 mm × 25 mm high steel c-section studs fitted at nominally 600 mm centres and 52 mm wide × 35 mm high steel U-channel head and base track, with 60 mm thick, 35 kg/m³ density mineral wool insulation friction fitted between the studs. The framing was clad on both faces with 2 layers of 12.5 mm thick Type F plasterboard.</p> <p>The services referenced in this assessment report are B, C, D, S, R. All pipes and cables measured 1200 mm long with a minimum of 500 mm protruding from the exposed face. The mineral wool insulation within the partition wall was removed for 100 mm surrounding all apertures.</p>
Instrumentation	The test report states that the instrumentation was in accordance with BS EN 1363-1:2012 and BS EN 1366-4:2009.

The test specimen achieved the following results – see Table 115.

Table 115 Results summary for this test report

Specimen	Aperture	Seal description	FRL
B	225 mm long × 225 mm wide	2 × 50 mm thick Protecta FR Board 1-S (160 kg/m ³) friction fitted back-to-back, sealed to the plasterboard with Protecta FR Acrylic	-/60/60
C	225 mm long × 225 mm wide	2 × 50 mm thick Protecta FR Board 1-S (160 kg/m ³) friction fitted back-to-back, sealed to the plasterboard with Protecta FR Acrylic	-/120/60
D	225 mm long × 225 mm wide	2 × 50 mm thick Protecta FR Board 1-S (160 kg/m ³) friction fitted back-to-back, sealed to the plasterboard with Protecta FR Acrylic	-/45/45
S	200 mm long × 300 mm wide	2 × 50 mm thick Protecta FR Board 1-S (160 kg/m ³) friction fitted back-to-back, sealed to the plasterboard with Protecta FR Acrylic	-/120/15
R – PP pipe with outer diameter 160 mm and wall thickness 14.6 mm	180 mm	Protecta FR collar fitted on both faces intumescent size 15 mm thick and 60 mm deep. FR Acrylic on both faces 10 mm wide and 25 mm deep.	-/60/60

B.28 Test report – WF 380977

Table 116 Information about test report

Item	Information about test report
Report sponsor	Polyseam AS, Shaw Park, Silver Street, Huddersfield, West Yorkshire, HD5, 9AF, UK.
Test laboratory	Warringtonfire, Chiltern House, Stocking Lane, High Wycombe, HP14, 4ND, UK.
Test date	The fire resistance test was completed on 16 March 2017.
Test standards	The test was done in accordance with BS EN 1366-3:2009 and BS EN 1366-4:2009.
Variation to test standards	None.
General description of tested specimen	The supporting construction comprised of a 3 m × 3 m × 150 mm thick blockwork wall in front of a 3 m × 3 m furnace. The services referenced in this assessment report are C-I. All pipes and cables measured 1200 mm long with a minimum of 500 mm protruding from the exposed face.
Instrumentation	The test report states that the instrumentation was in accordance with BS EN 1363-1:2012 and BS EN 1366-4:2009.

The test specimen achieved the following results – see Table 117.

Table 117 Results summary for this test report

Specimen	Aperture	Seal description	FRL
C - PP pipe with outer diameter 110 mm and wall thickness 10.0 mm	127 mm	Pipe capping: U/U Protecta FR collar intumescent size 6 mm thick × 50 mm wide. Rock mineral fibre applied to a width of 8.5 mm and a depth of 20 mm. Protecta FR Acrylic on both faces, 8.5 mm wide by 10 mm deep.	-/15/15
D - PE pipe with outer diameter 110 mm and wall thickness 10.0 mm	127 mm	Pipe capping: U/U Protecta FR collar intumescent size 6 mm thick × 50 mm wide. Rock mineral fibre applied to a width of 8.5 mm and a depth of 20 mm. Protecta FR Acrylic on both faces, 8.5 mm wide by 10 mm deep.	-/45/45
E - PP pipe with outer diameter 110 mm and wall thickness 10.0 mm	127 mm	Pipe capping: U/C Protecta FR collar intumescent size 6 mm thick × 50 mm wide. Rock mineral fibre applied to a width of 8.5 mm and a depth of 20 mm. Protecta FR Acrylic on both faces, 8.5 mm wide by 10 mm deep.	-/240/240
F – blank seal	480 mm long × 480 mm × 150 mm wide	2 × 60 mm thick Protecta FR boards 2-S sealed to the supporting construction with Protecta FR Acrylic. Fitted flush with the face of the supporting construction with 30 mm air space between.	-/240/240
G – blank seal	480 mm long × 480 mm × 150 mm wide	2 × 60 mm thick Protecta FR boards 2-S sealed to the supporting construction with Protecta FR Acrylic. Fitted flush with the face of the supporting construction with 30 mm air space between.	-/180/45

Specimen	Aperture	Seal description	FRL
H – blank seal	600 mm long × 1200 mm × 150 mm wide	2 × 60 mm thick Protecta FR boards 2-S sealed to the supporting construction with Protecta FR Acrylic. Fitted flush with the face of the supporting construction with 30 mm air space between.	-/60/45
I – blank seal	600 mm long × 1200 mm × 150 mm wide	1 × 60 mm thick Protecta FR boards 2-S sealed to the supporting construction with Protecta FR Acrylic.	-/240/60